

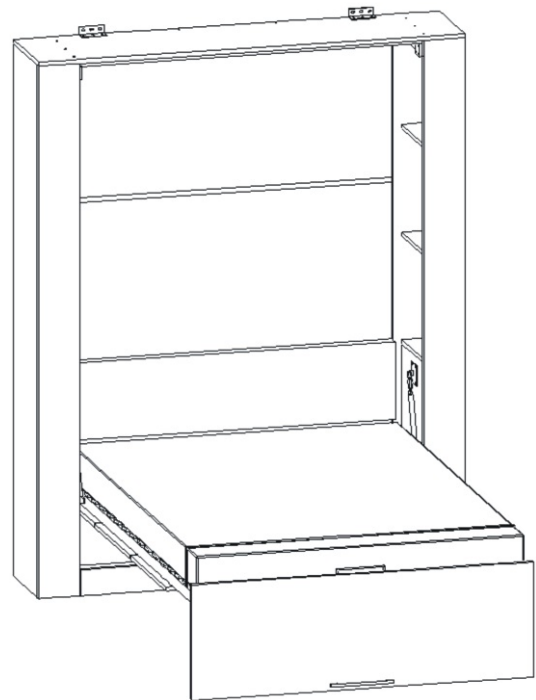

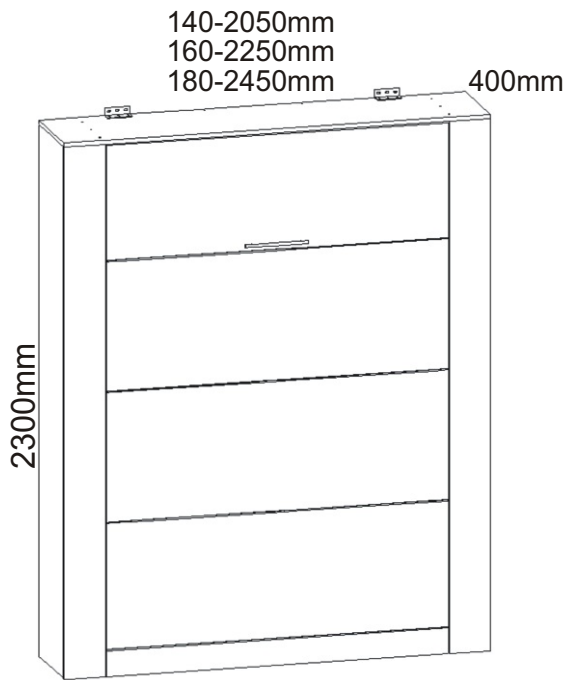







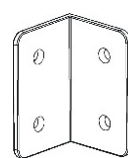

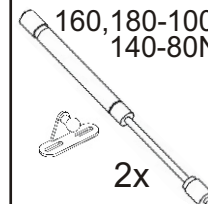
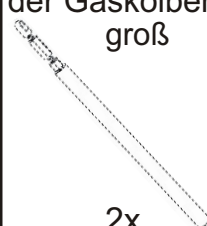

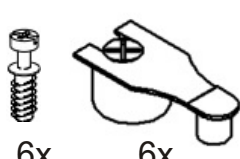
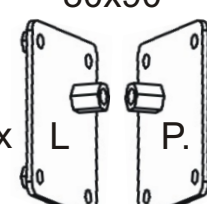
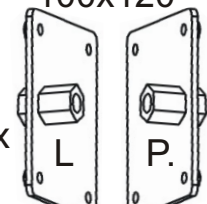
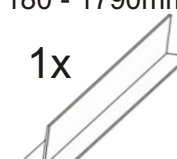



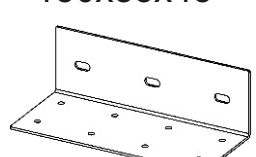
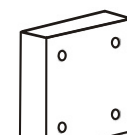
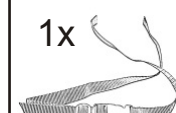
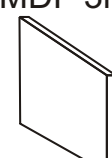
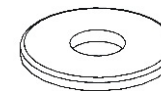

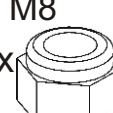
VS 4070P 140,160,180

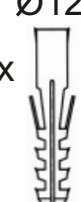

<p>die Befestigungsschraube 50mm</p>  <p>32x</p>	<p>der Winkel klein</p>  <p>4x</p>	<p>der Stift 35mm</p>  <p>50x</p>	<p>der Kleber groß</p>  <p>1x</p>	<p>der Gaskolben klein 160,180-100N 140-80N</p>  <p>2x</p>	<p>der Gaskolben groß</p>  <p>2x</p>	<p>die Stütze</p>  <p>20x</p>		
<p>der Verbindungsmechanismus Groß</p>  <p>6x</p>	<p>das Absetzblech 80x90</p>  <p>1x</p>	<p>das Absetzblech 100x120</p>  <p>1x</p>	<p>Al T die Leiste 140 - 1390mm 160 - 1590mm 180 - 1790mm</p>  <p>1x</p>	<p>M 6x35 die Senkschraube</p>  <p>16x</p>	<p>V4x35</p>  <p>21x</p>	<p>V4x50</p>  <p>28x</p>		
<p>der Winkel 150x85x45</p>  <p>2x</p>	<p>der Türstopper</p>  <p>2x</p>	<p>der Gurt</p>  <p>1x</p>	<p>die Sperrvorrichtung MDF 3mm</p>  <p>6x</p>	<p>die Unterlage M13</p>  <p>4x</p>	<p>die Schraubenabdeckung</p>  <p>13x</p>	<p>die Mutter M8</p>  <p>2x</p>		
<p>der Halter 192mm</p>  <p>1x</p>	<p>der Dübel Ø12</p>  <p>6x</p>	<p>M8x25</p>  <p>2x</p>	<p>M12x70</p>  <p>2x</p>	<p>V4x17</p>  <p>100x</p>	<p>V4x20</p>  <p>16x</p>	<p>V4x16</p>  <p>16x</p>	<p>V6x70</p>  <p>6x</p>	<p>der Kolbenabdeckung</p>  <p>2x</p>

1.

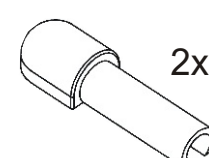
Es ist wichtig, die Verbindungsmechanismen auf beiden Seiten gleichzeitig zu klopfen, um ein Brechen zu vermeiden.

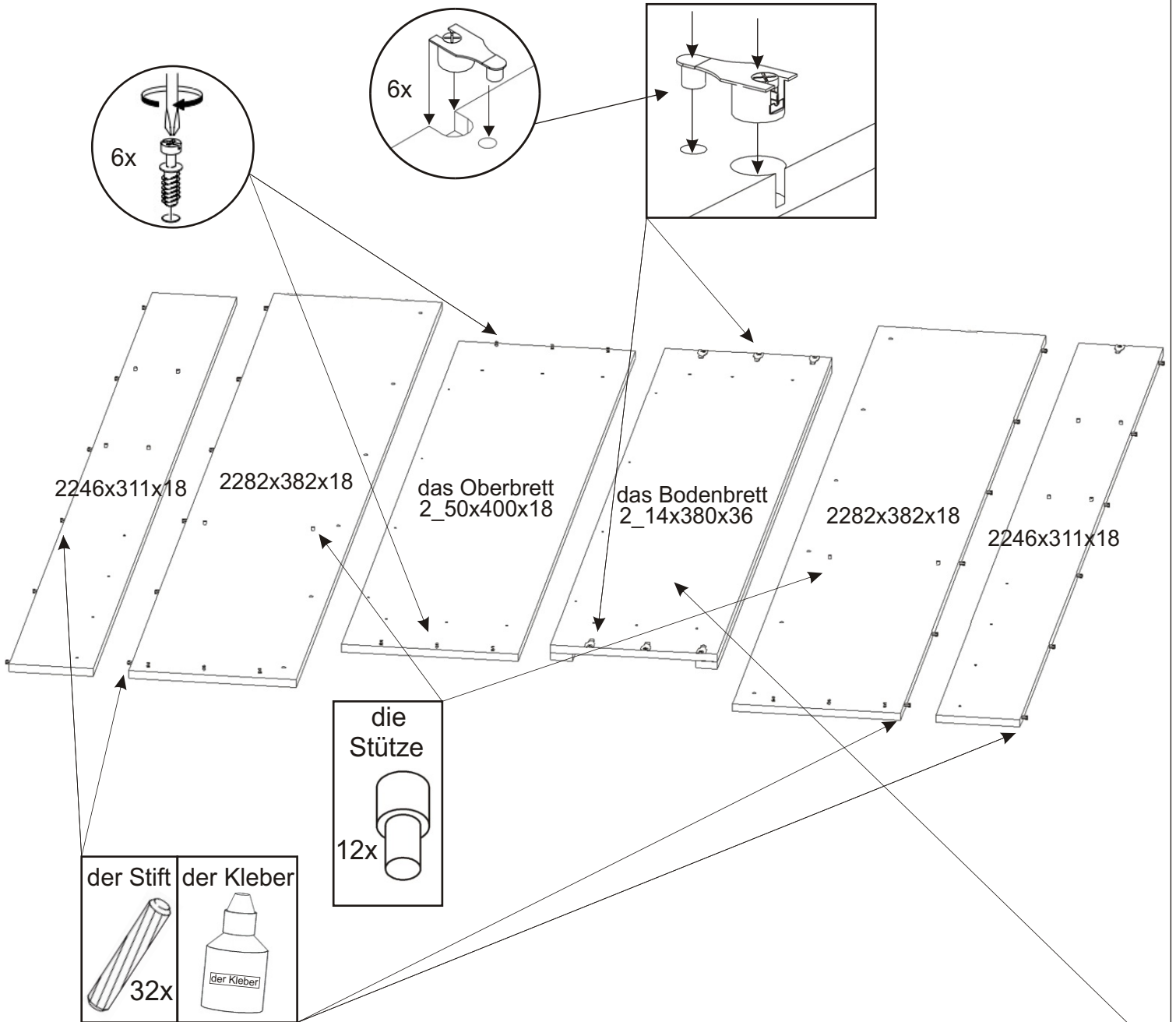

2.

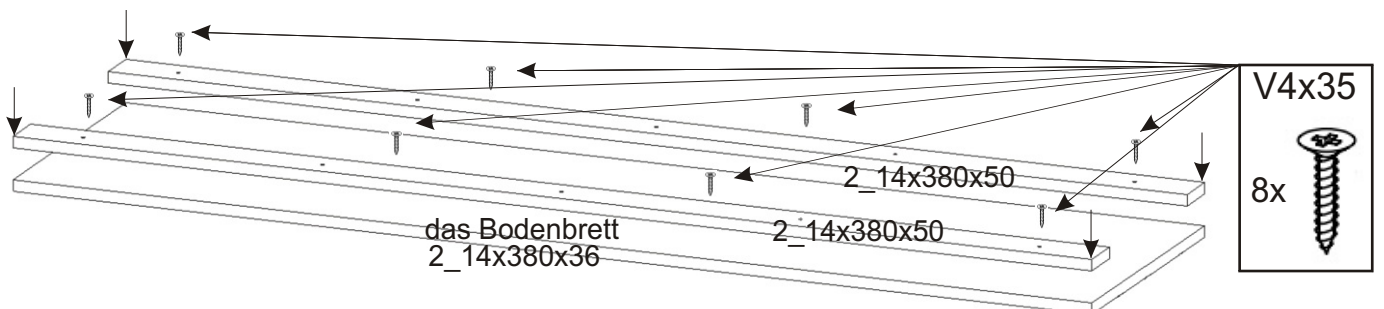

3.

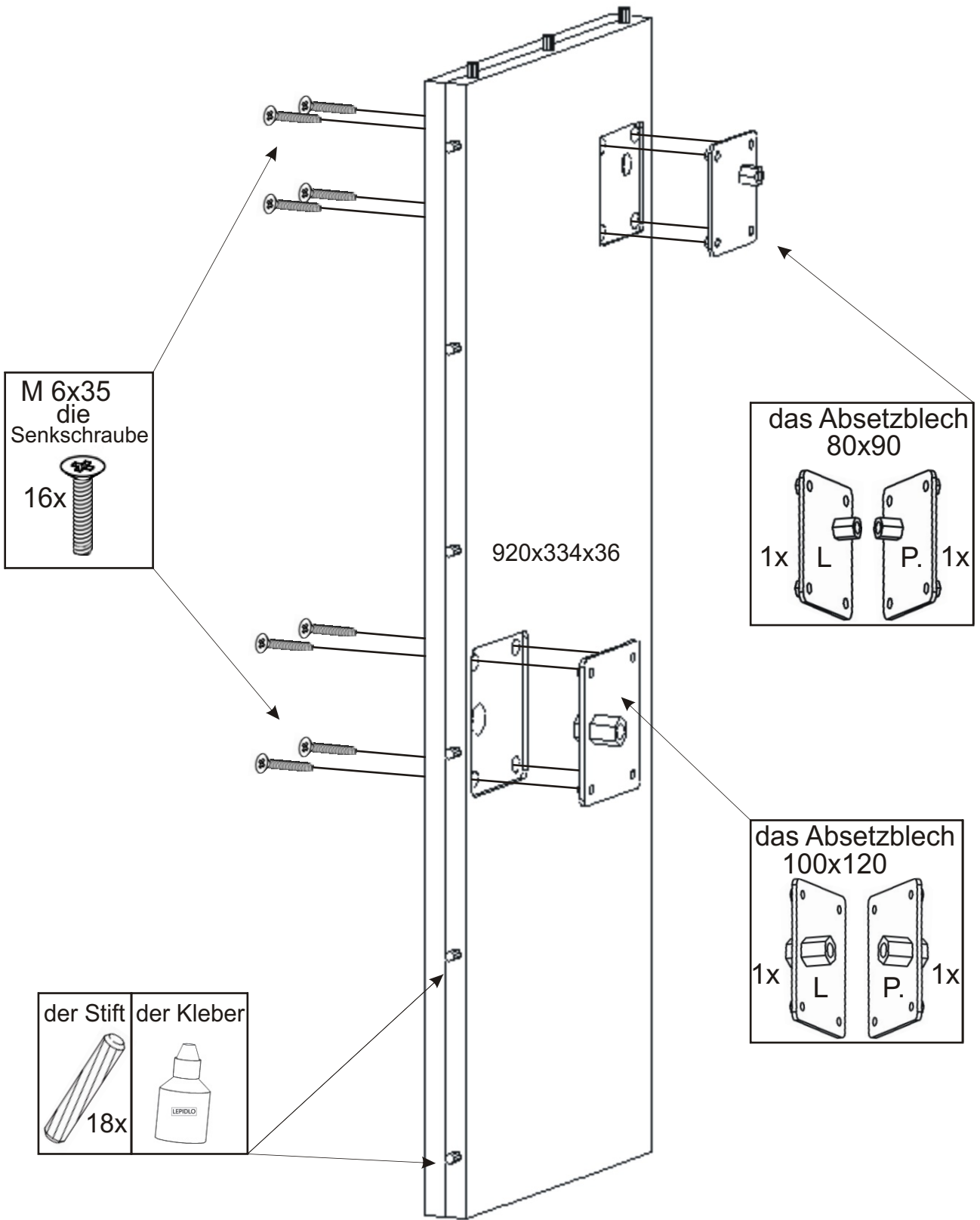

4.

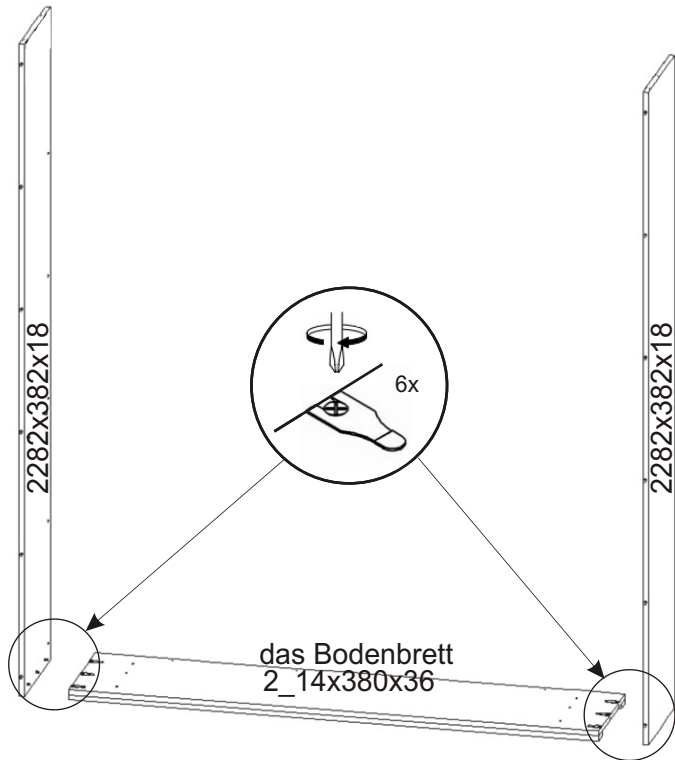

5.

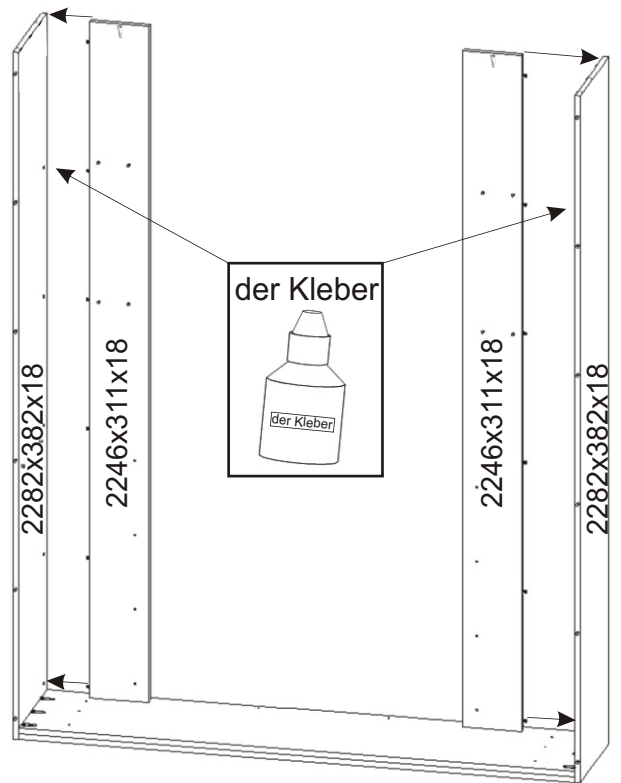

6.

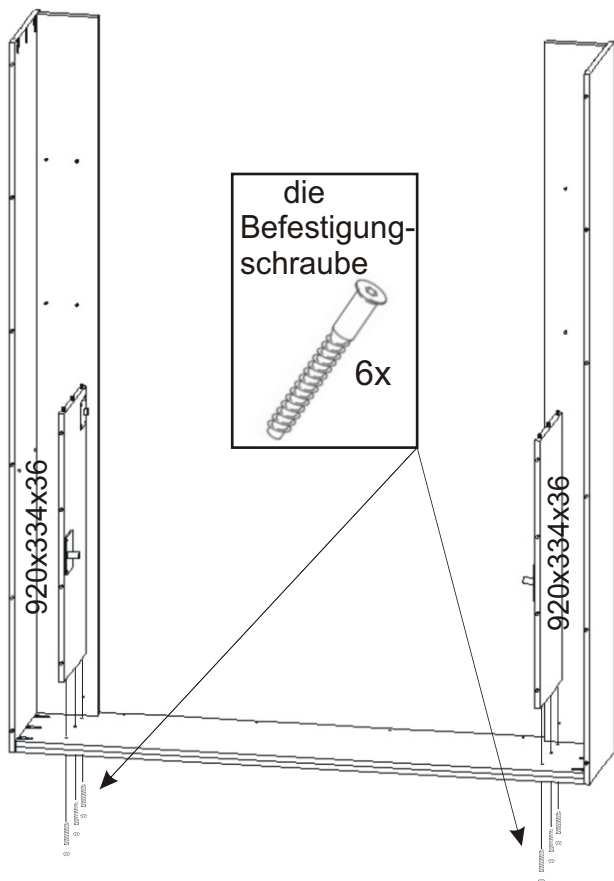

7.

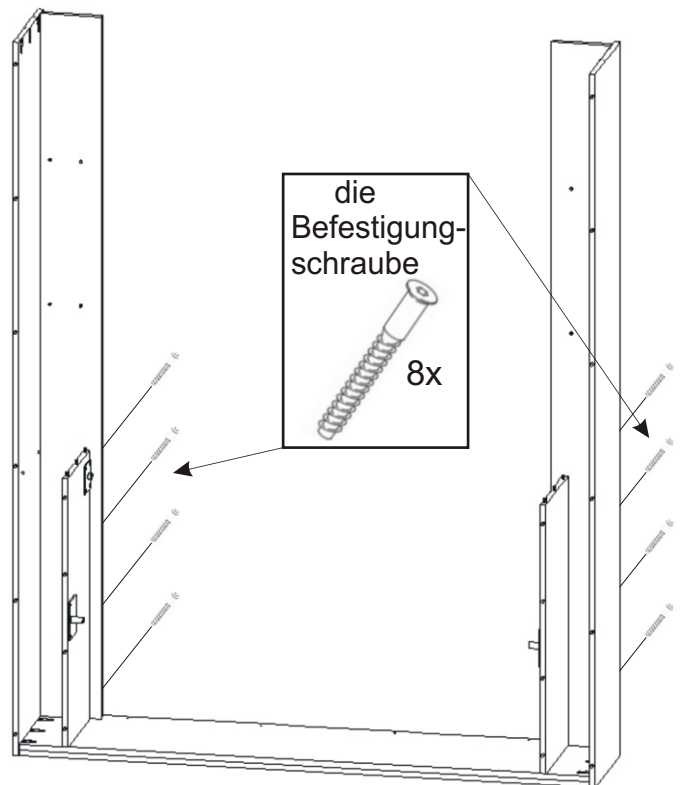

8.

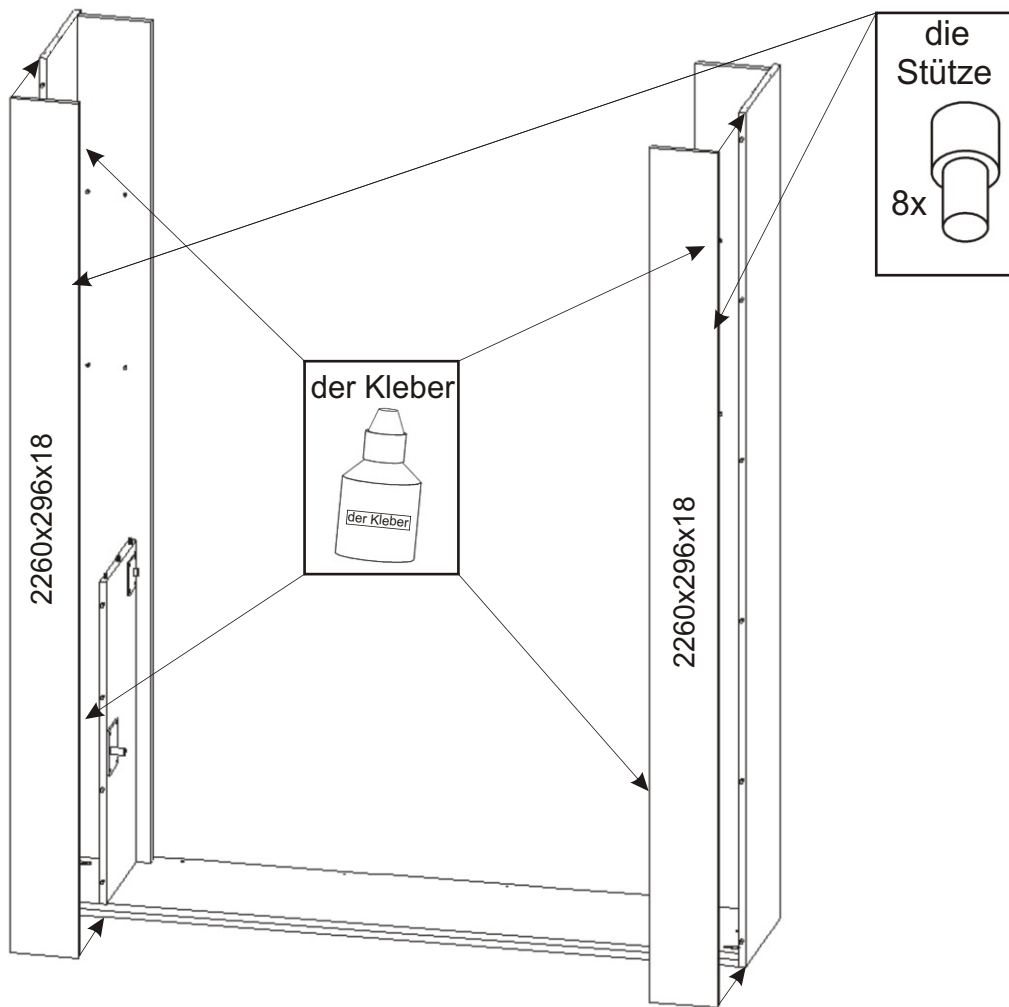

9.

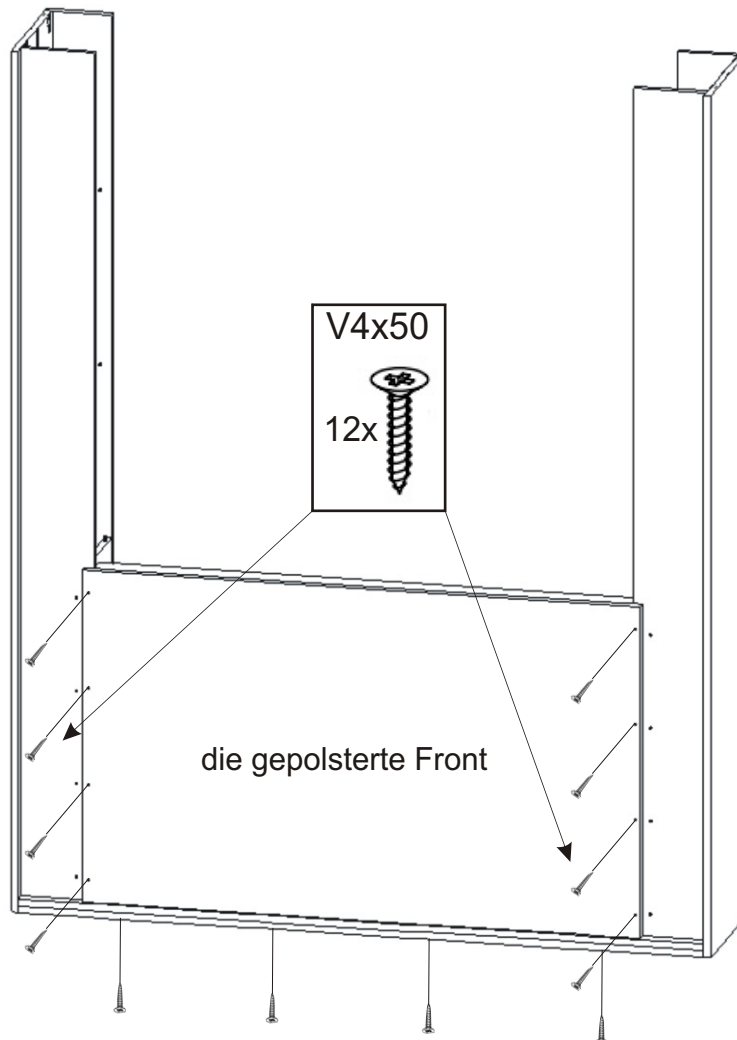

10.

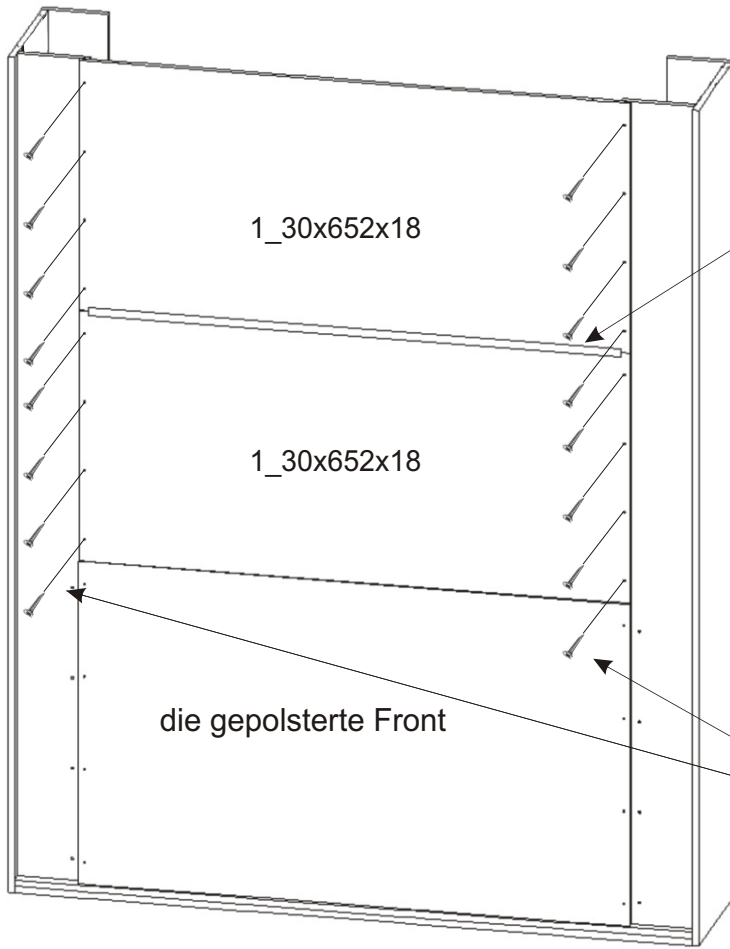

Al T die Leiste
140 - 1390mm
160 - 1590mm
180 - 1790mm

1x

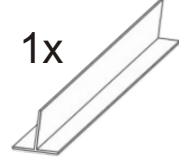

Legen Sie die AL-Leiste zwischen die Rückens ein.

V4x50

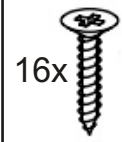

16x

11.

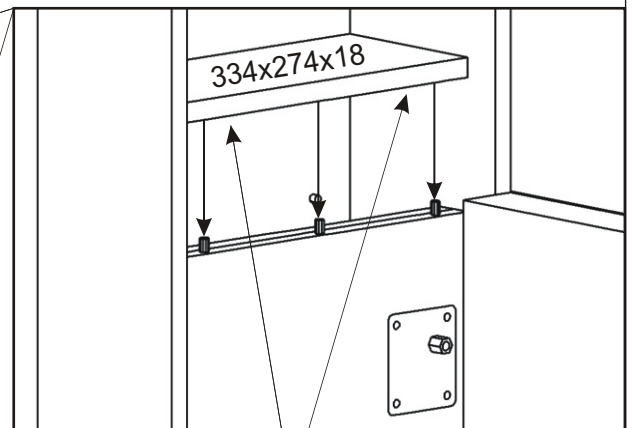
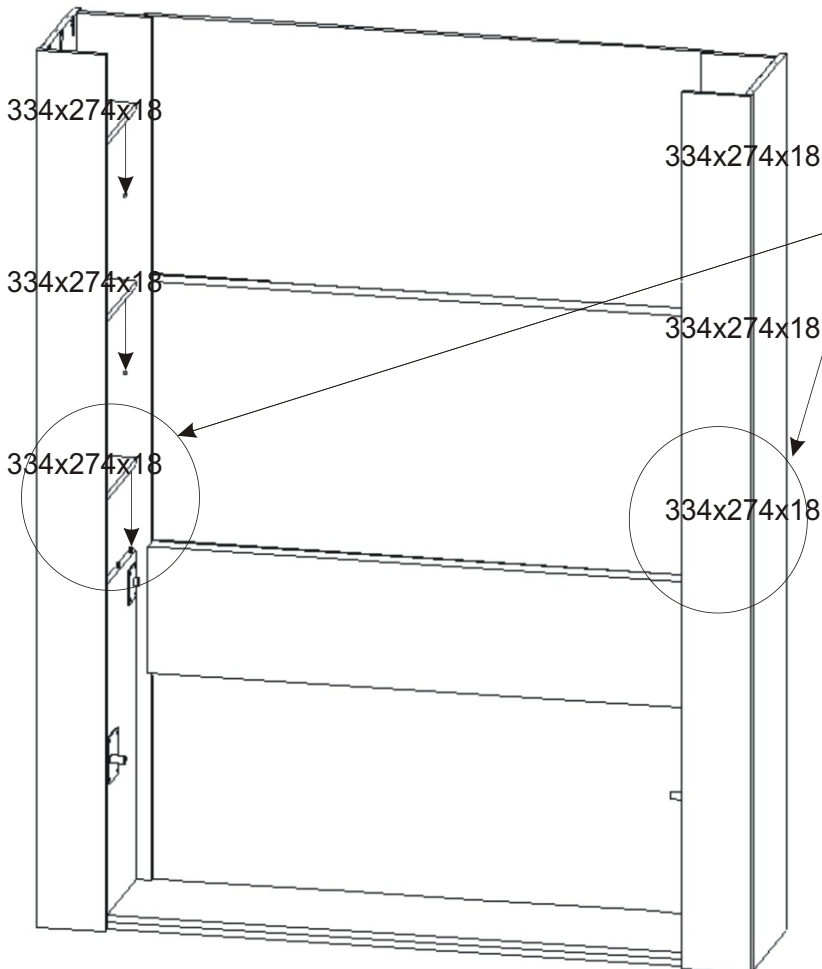

der Kleber



12.

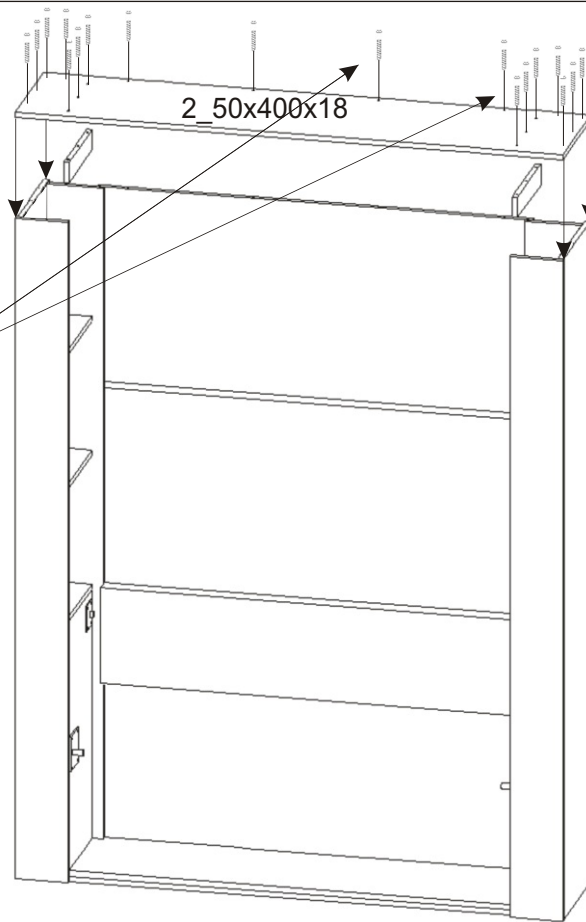

13. *Das Klappbett muss vor dem Anbringen des Metallrostes an der Wand befestigt werden! Andernfalls besteht Sturzgefahr beim Öffnen.*

Die Anzahl und die Art der Dübeln muss durch die Art der Wand bestimmt werden.

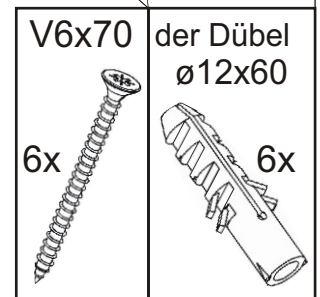
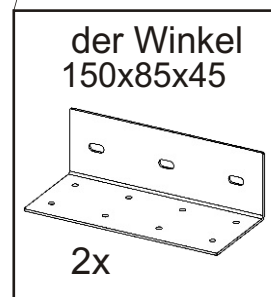
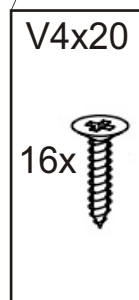
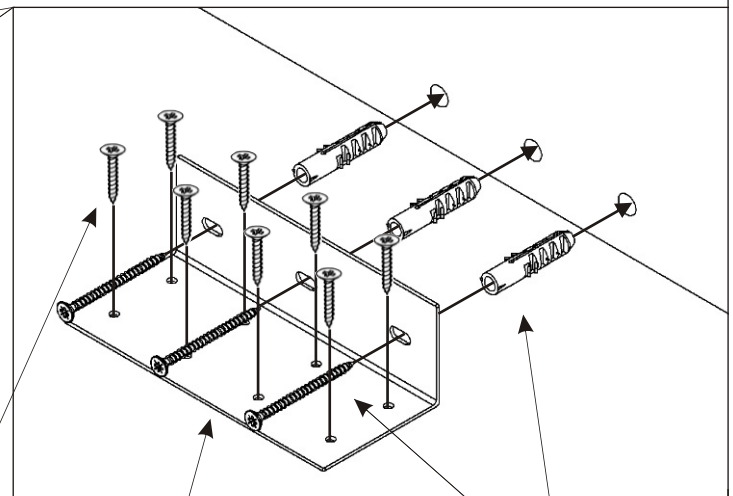
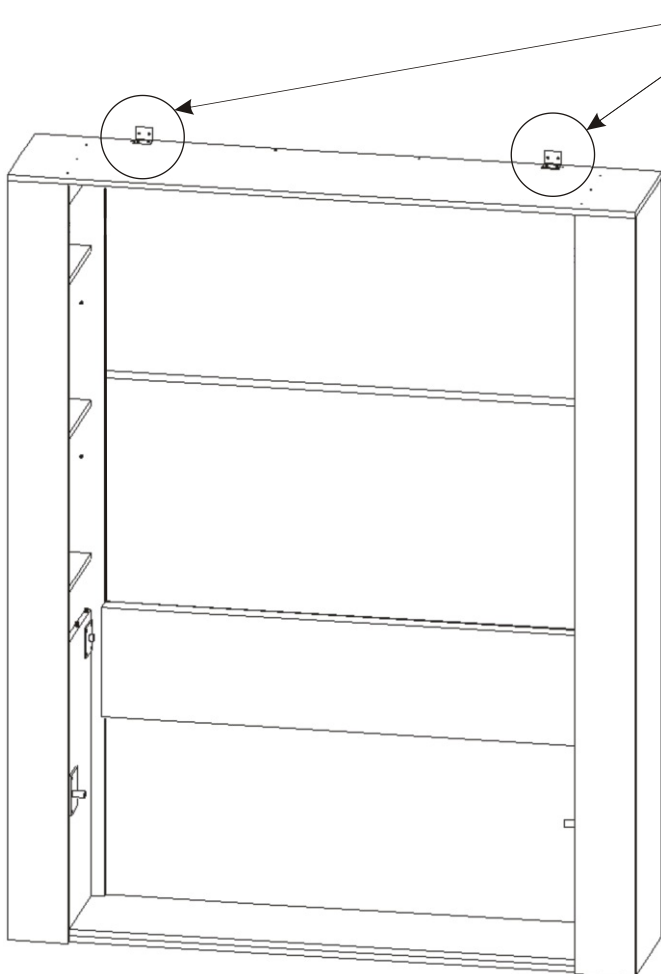

14.

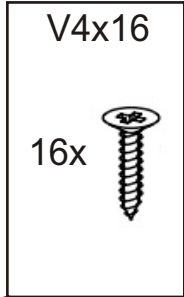
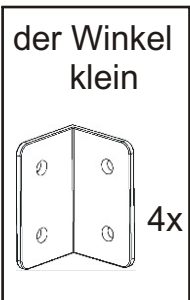
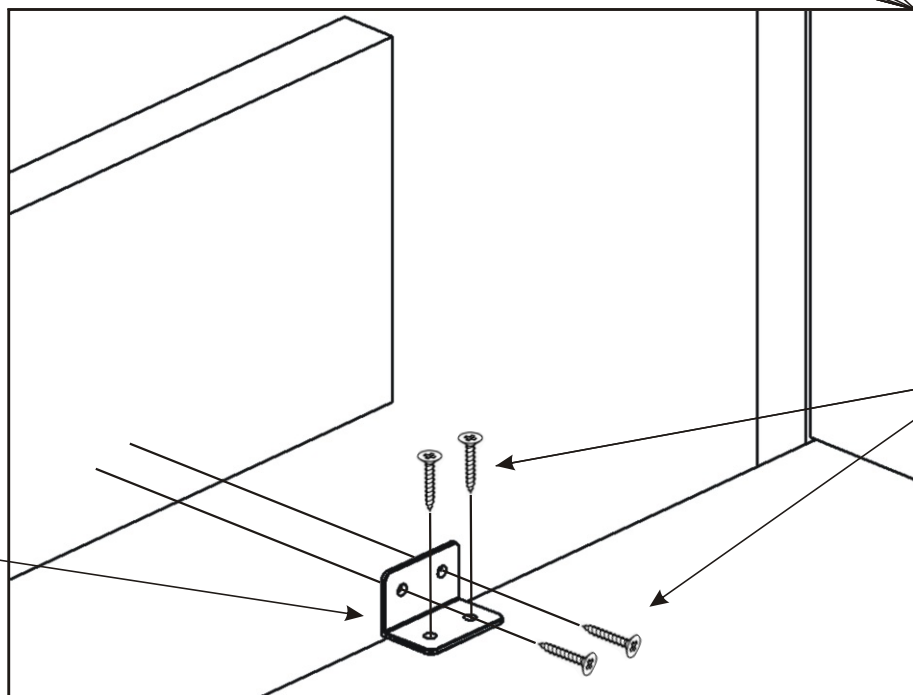
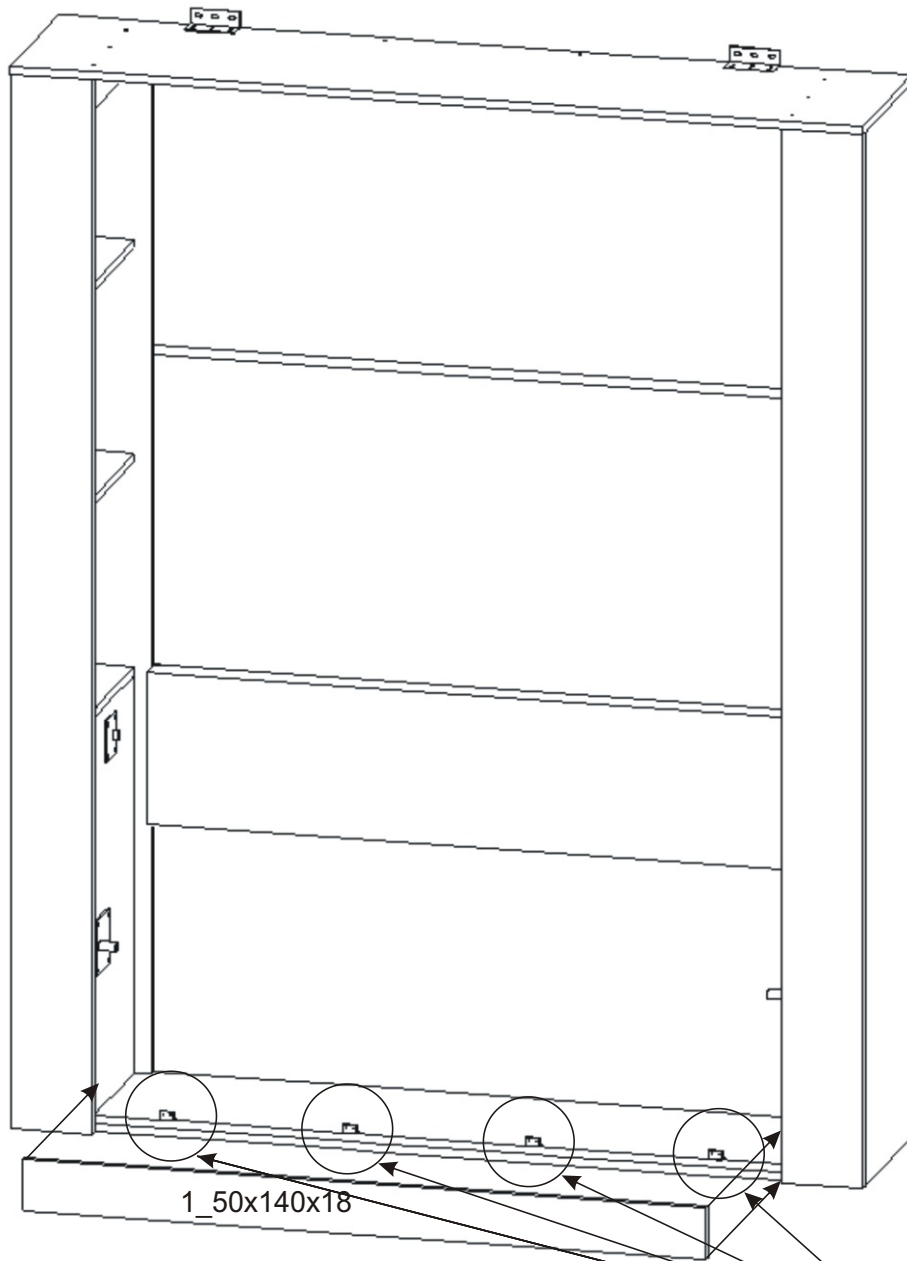

15.9.

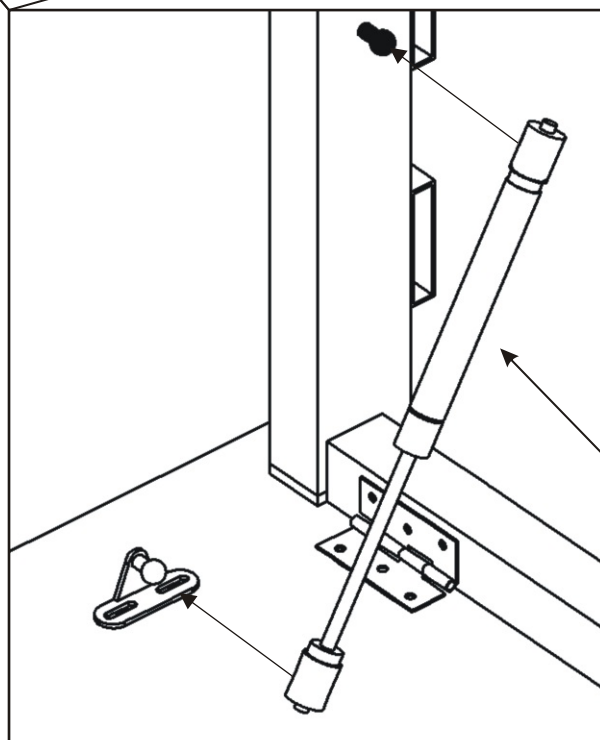
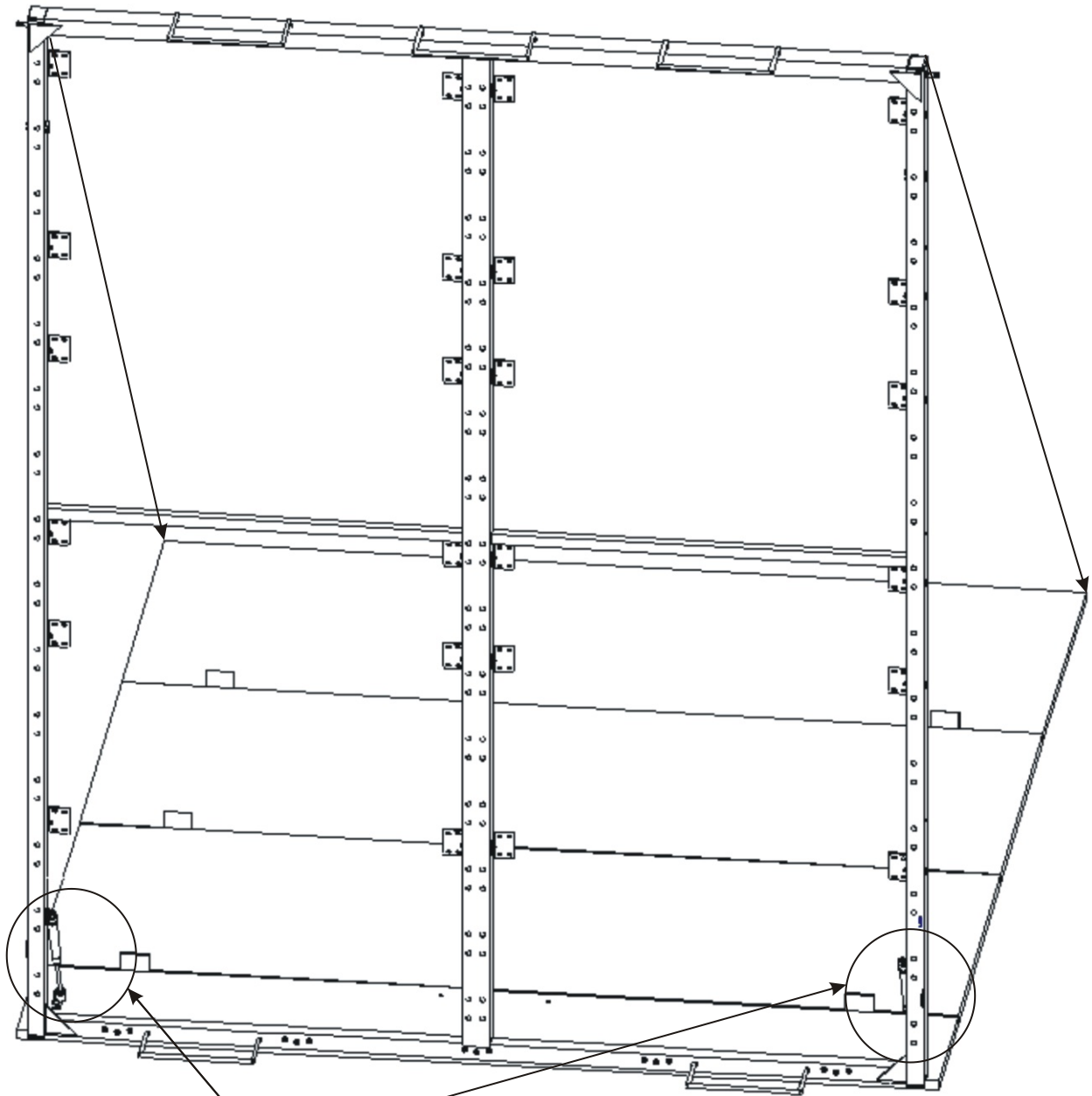

der Gaskolben
klein
2x



15.10. Andere Türen anbringen

V - 4x17
64x

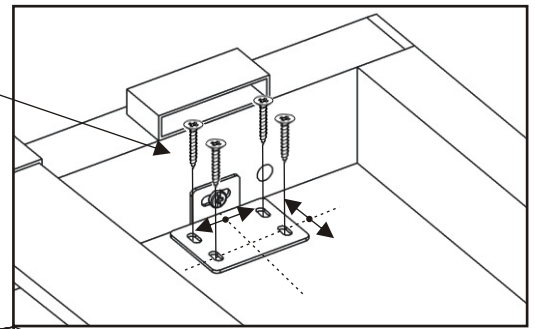
Richten Sie die Türkanten an der Ebene aus.

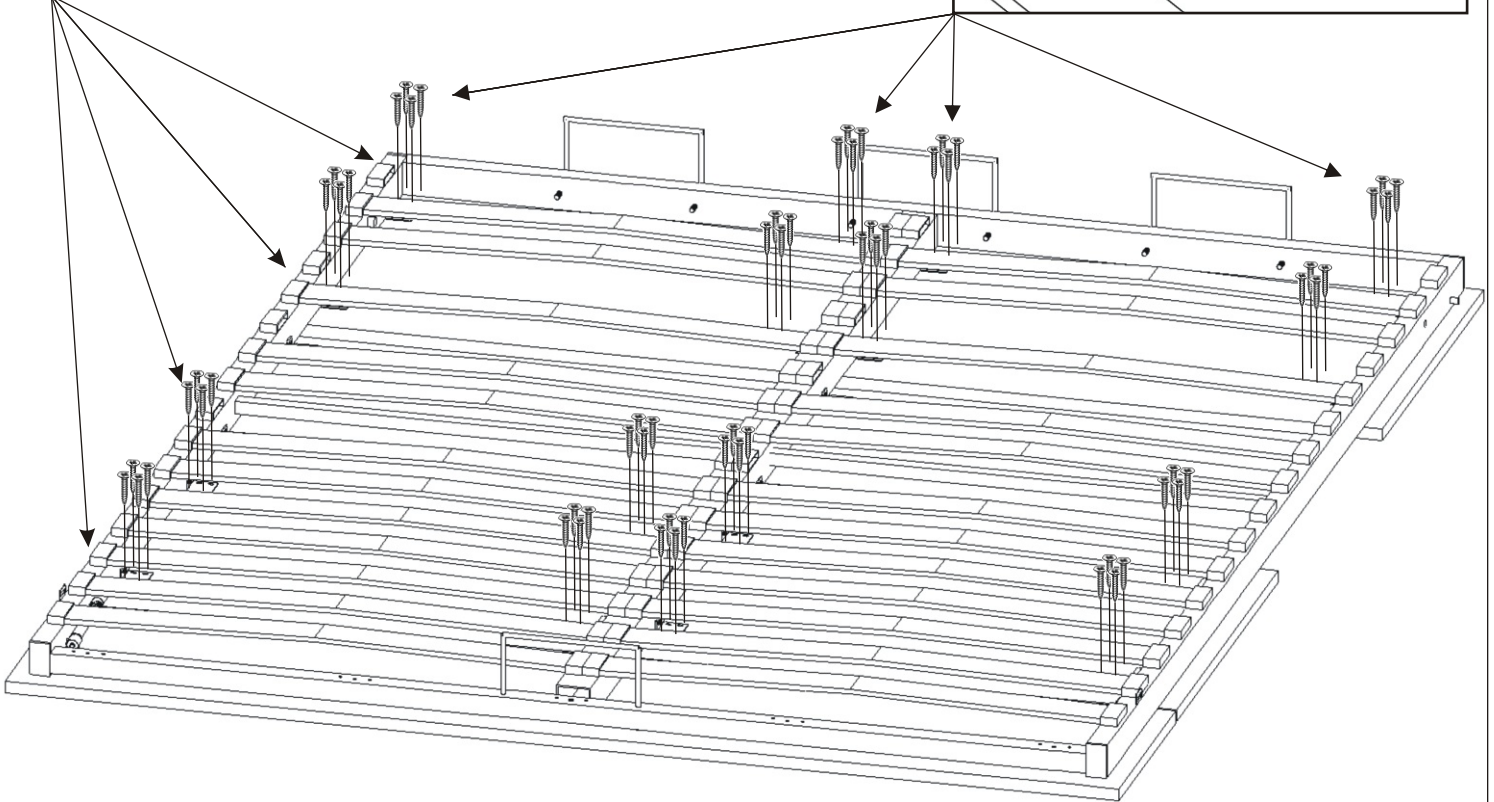

Einsatz von Lamellen

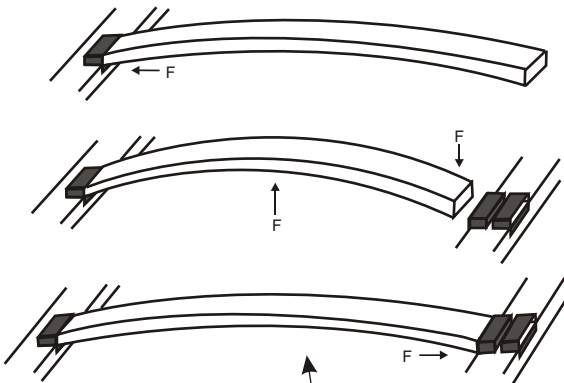

die Lamelle
24x



die Türmontage

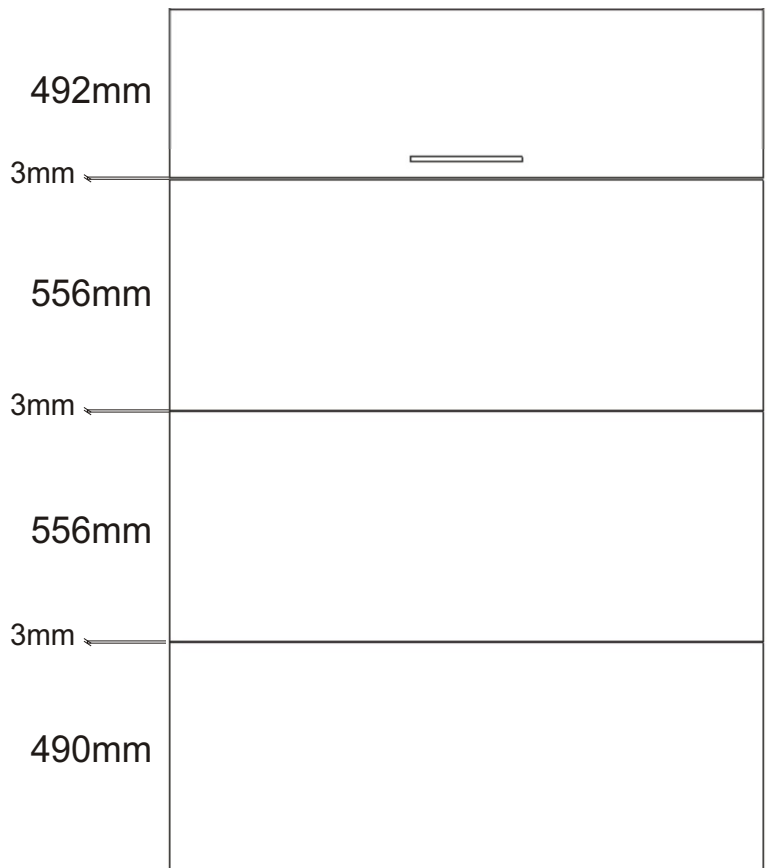

15.11 Anbringen eines großen Kolbens

Befestigen Sie den großen Kolben am Rahmen und sichern Sie ihn mit einer Mutter. Ziehen Sie die Mutter nicht fest, der Kolben muss sich bewegen können.

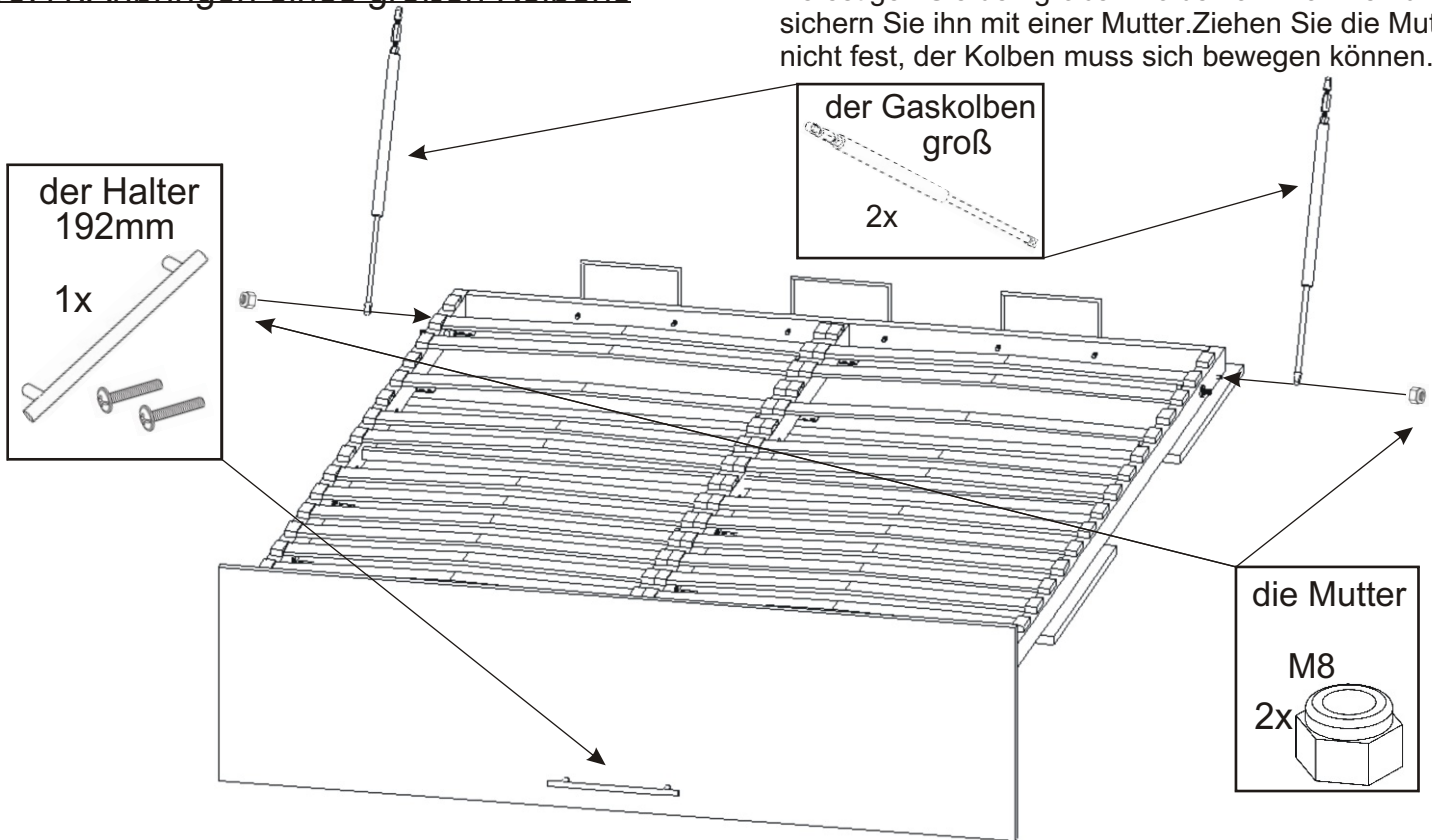

16.

1. Schieben Sie den Rahmen mit einem Kollegen in der Körper.
2. Schrauben Sie den Bettrahmen mit einer M12x70-Schraube und einer Unterlegscheibe an die Bodenplatte des Bettkörpers an.

Ziehen Sie nicht die Schrauben fest, der Rahmen muss sich frei drehen lassen!

die Unterlage
M13
4x

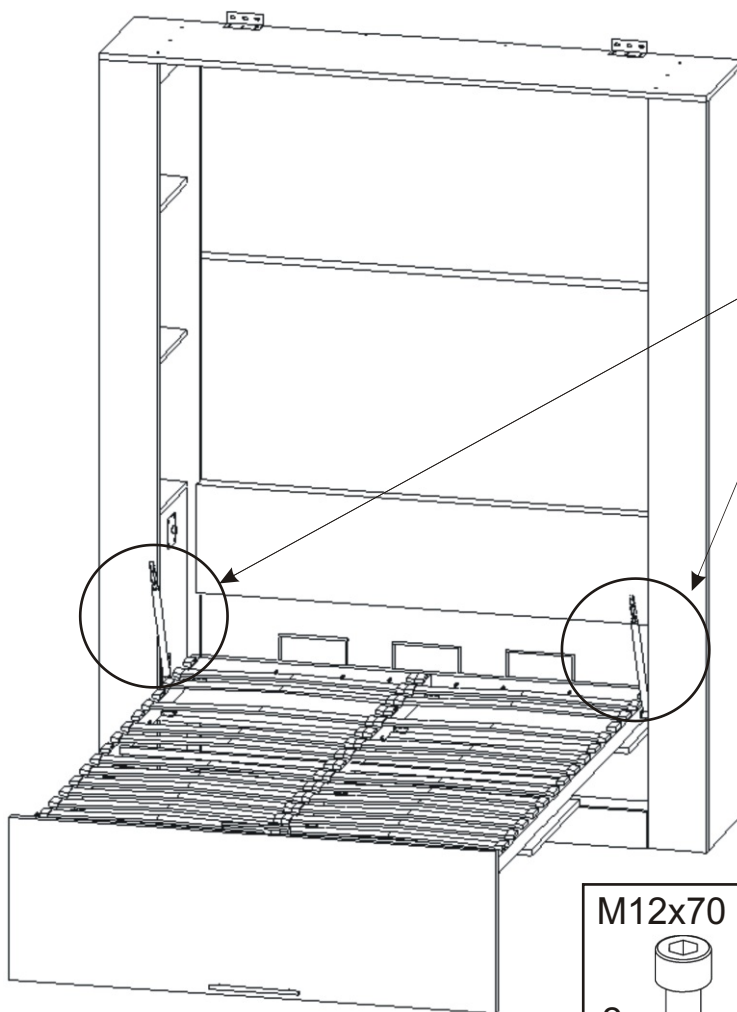
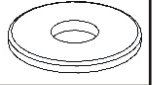

16.1.

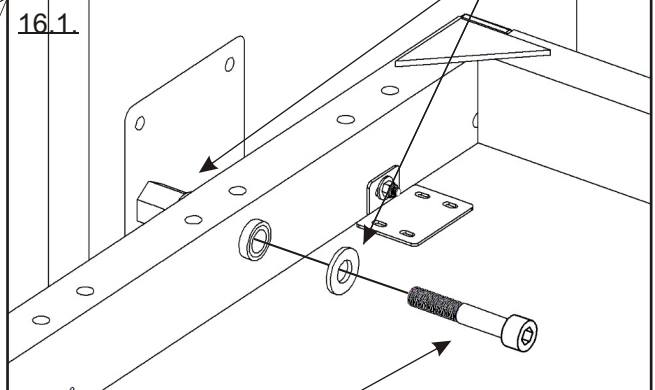

16.2.

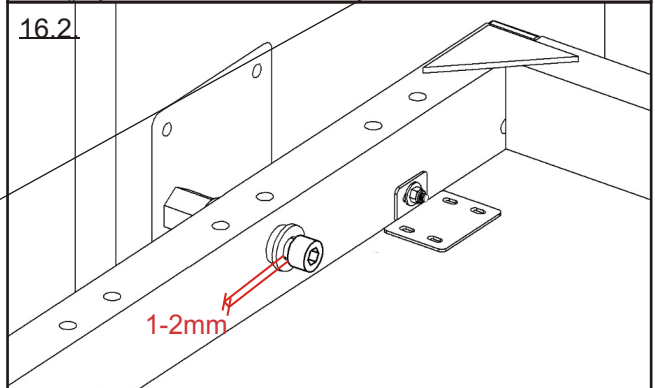

M12x70

2x



Ziehen Sie die Schraube M12x70 nicht ganz fest, sondern lassen Sie einen Spalt von ca. 1-2 mm zwischen Schraubenkopf und Unterlegscheibe. Andernfalls besteht die Gefahr einer irreparablen Beschädigung des Rahmens !!!

17.

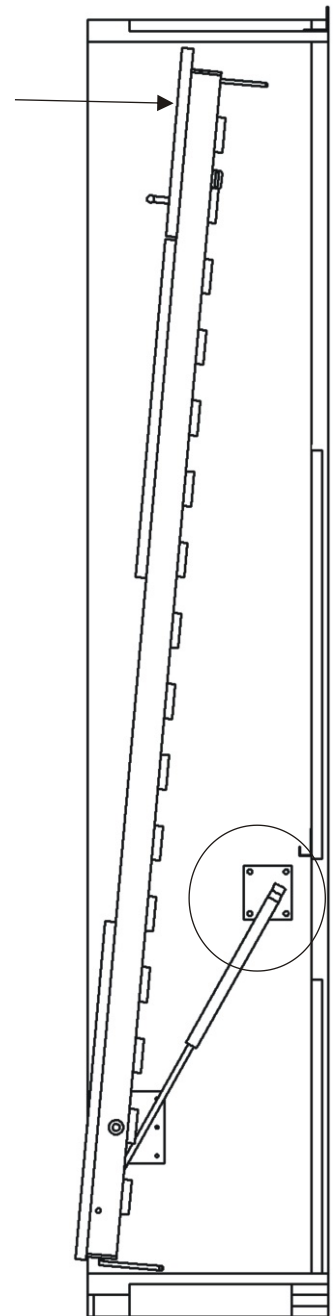
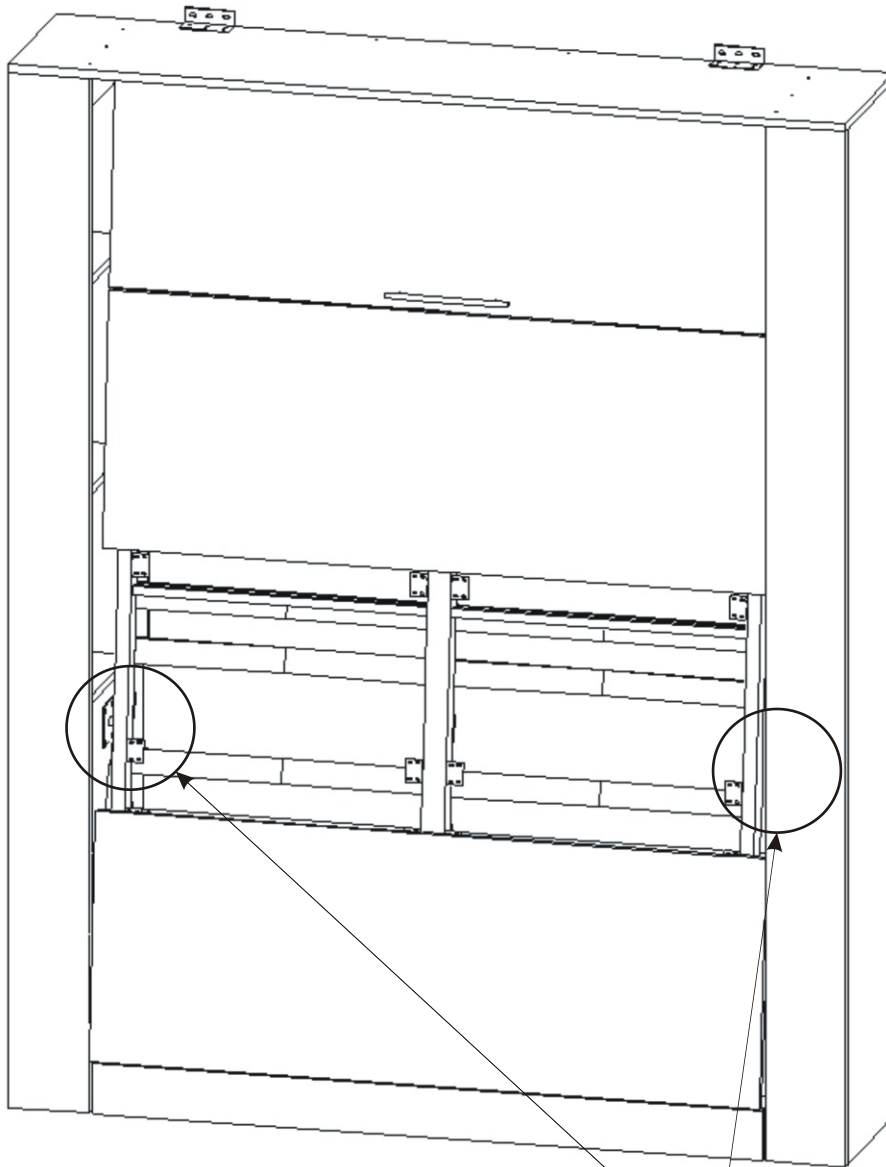

1. Stellen Sie die Tür in eine horizontale Position und schieben Sie den gesamte bewegliche Teil nach innen.
2. Setzen Sie nun die Kolben locker in den oberen Stifte ein.

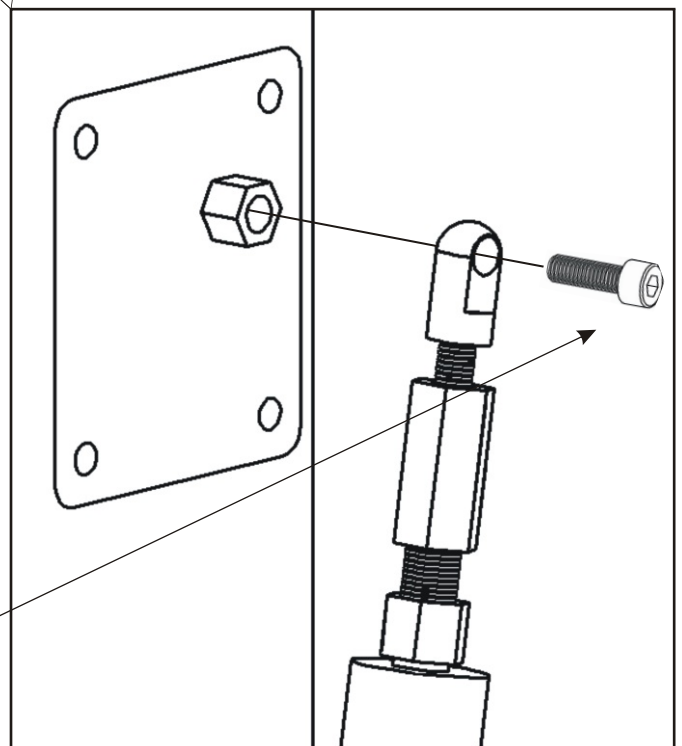
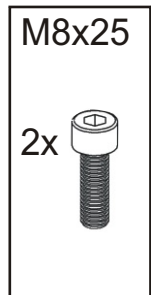

18. Einstellung zum Anziehen der Tür

Verwenden Sie diese Kolbeneinstellung nur, wenn sich die Tür und die Matratze nicht schließen zusammen.

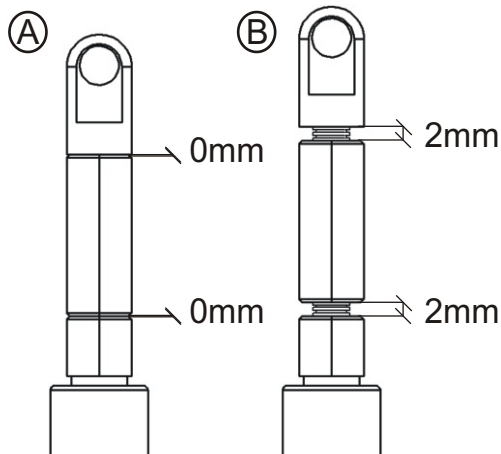
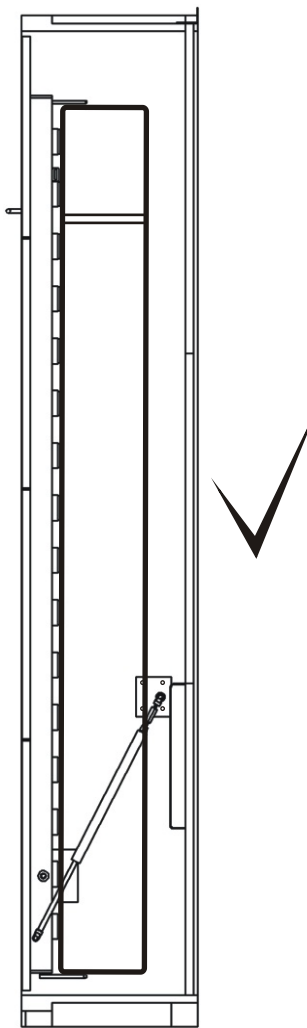
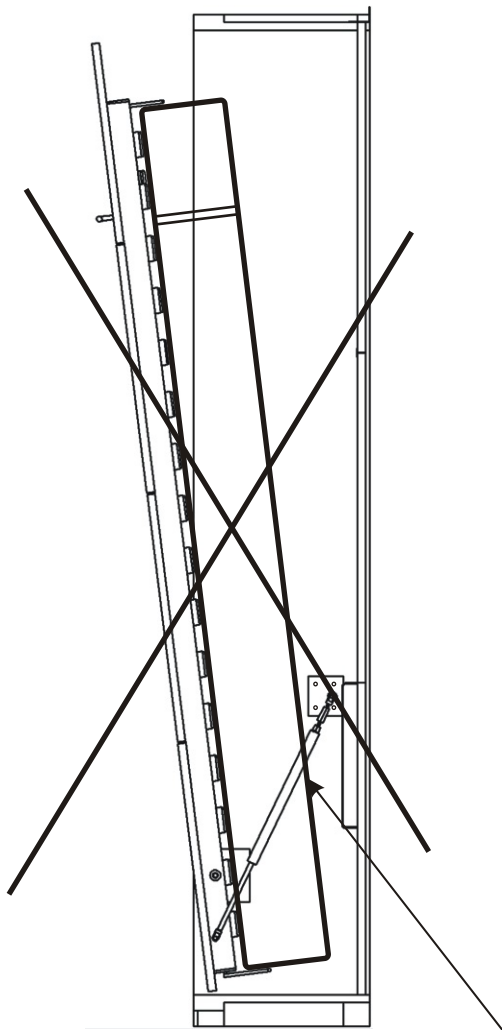

Die Einstellung des Abstands der Kolben

Zur Montage des Klappbettes verwenden Sie die Kolben, die als in der Abbildung A eingestellt sind. Wenn sich die Tür mit der Matratze nicht übereinstimmt, stellen Sie den Kolbenabstand ein, in dem Sie ihn leicht um ca. 1 bis 2mm öffnen. Maximal 2mm!!! Wenn Sie einen größeren Abstand einstellen, werden die Kolben dauerhaft beschädigt. Dieser Schaden werden von der Reklamation abgedeckt.

der Kolbenabdeckung

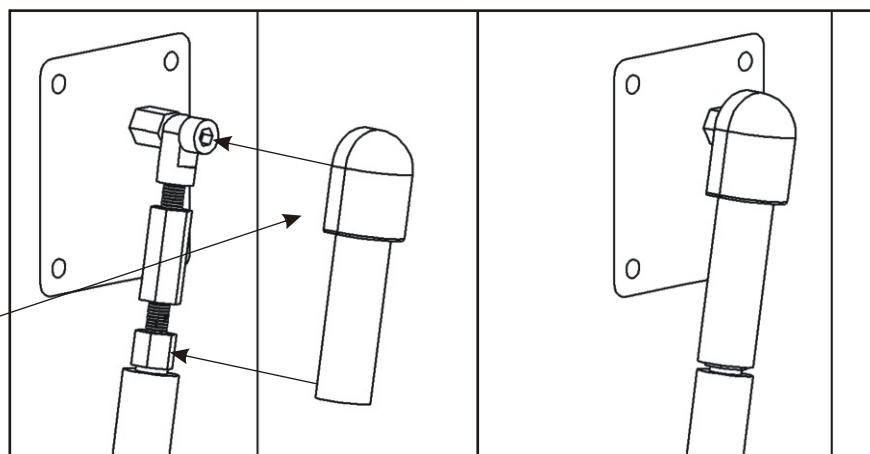
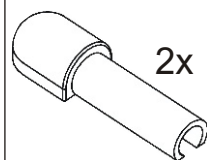

19.

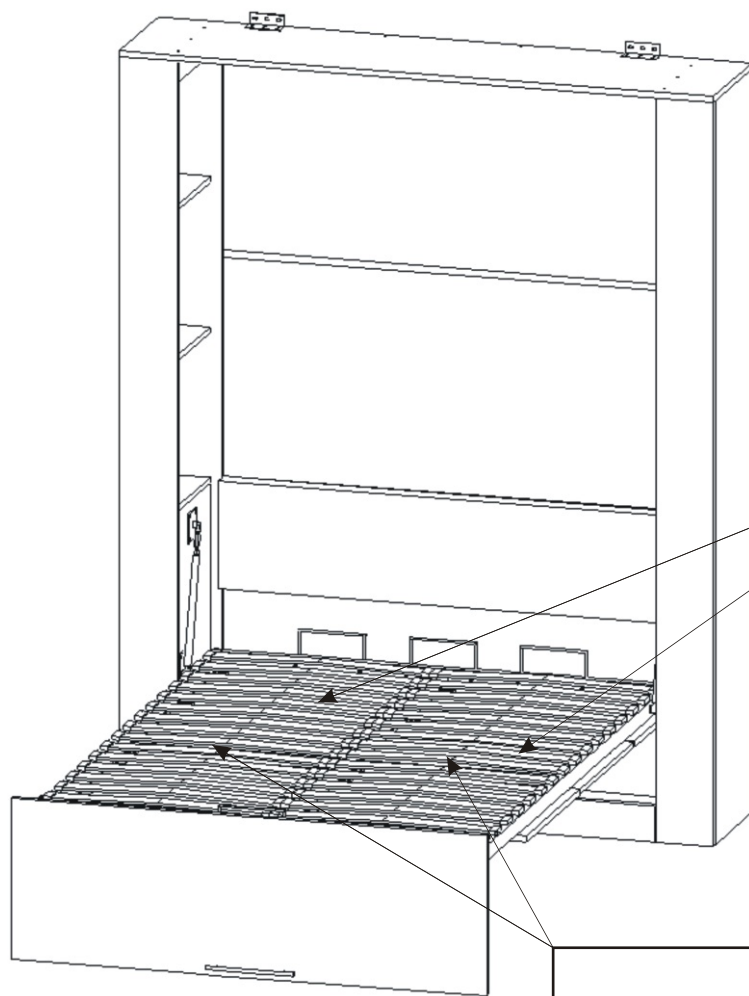
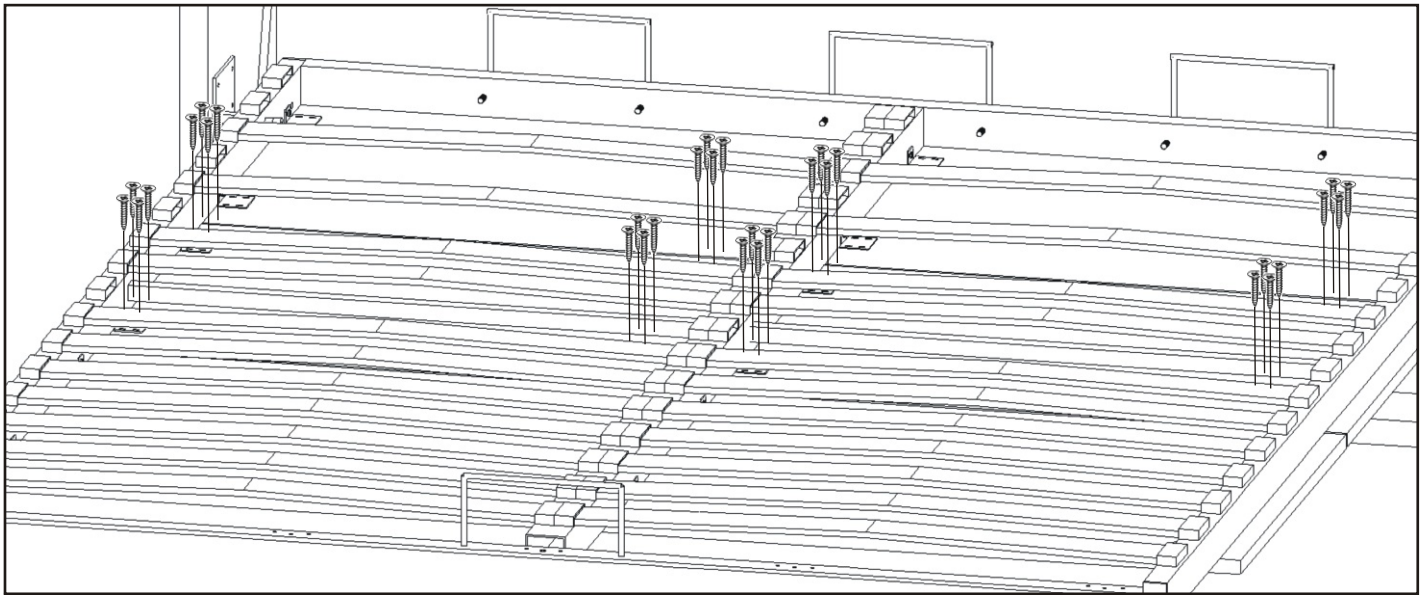

die Lamelle
6x



die Sperrvorrichtung
MDF 3mm
6x



Richten Sie die Türkanten an der Ebene aus

V4x17

32x

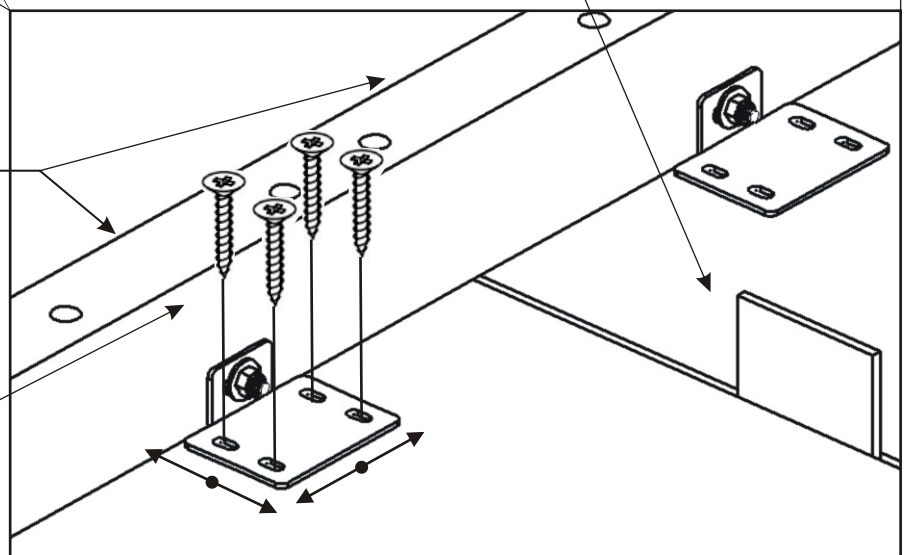

20.

Befestigen Sie die Stoppleiste 20mm von der Vorderkante.

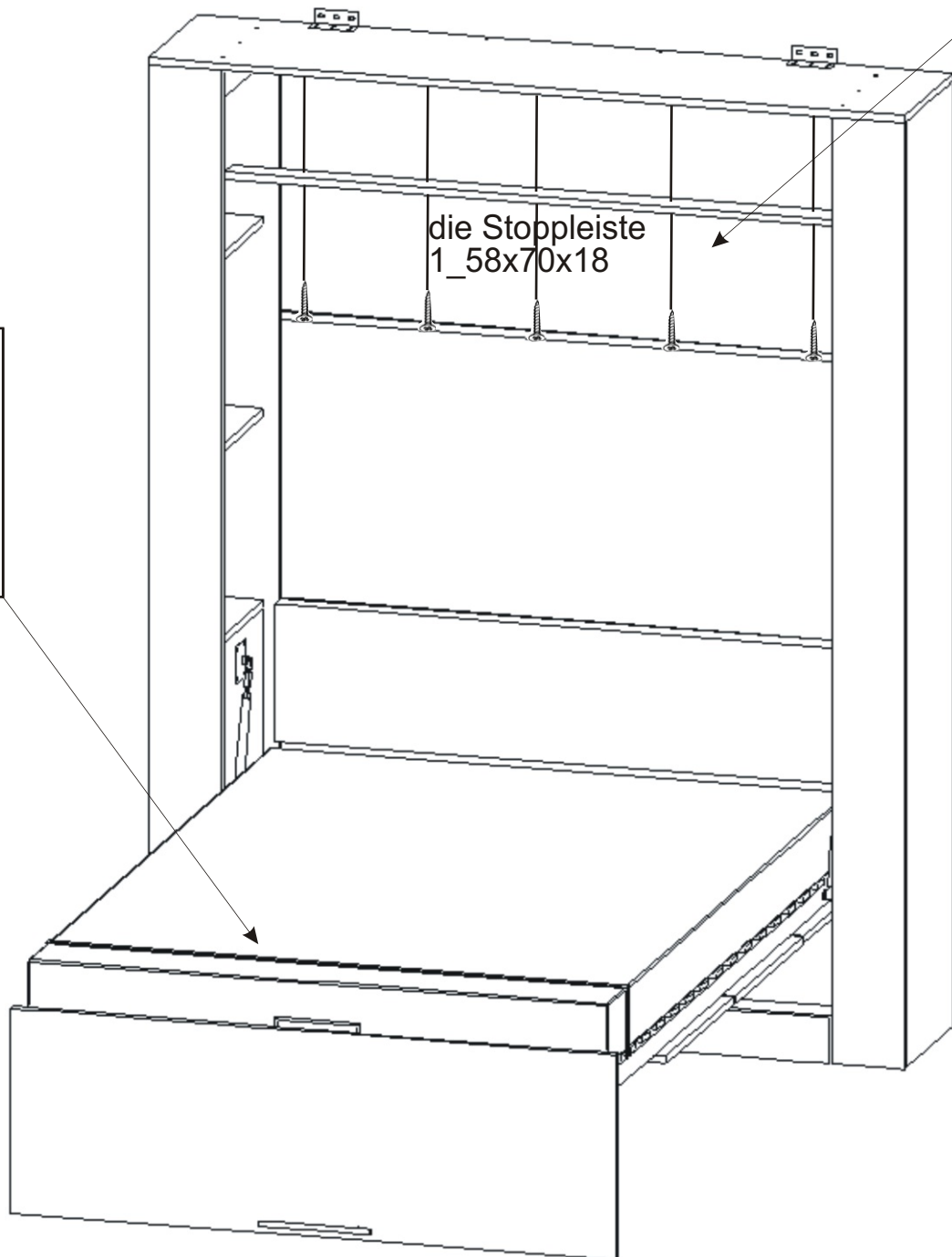
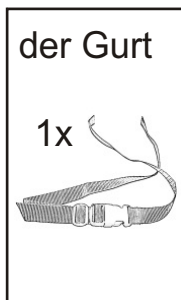
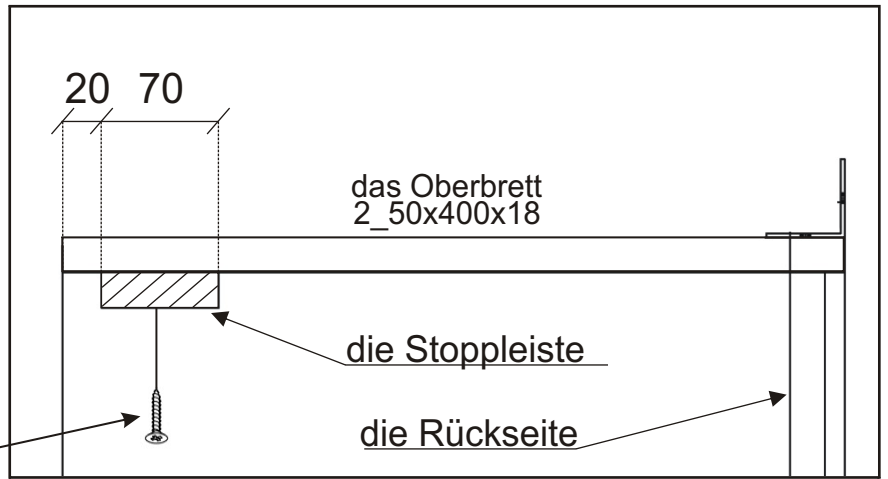
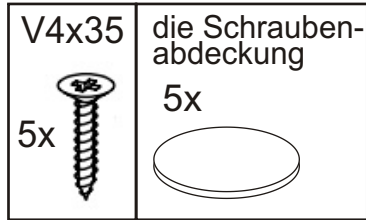

21.

der Türstopper

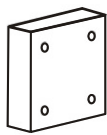

2x

die Stoppleiste

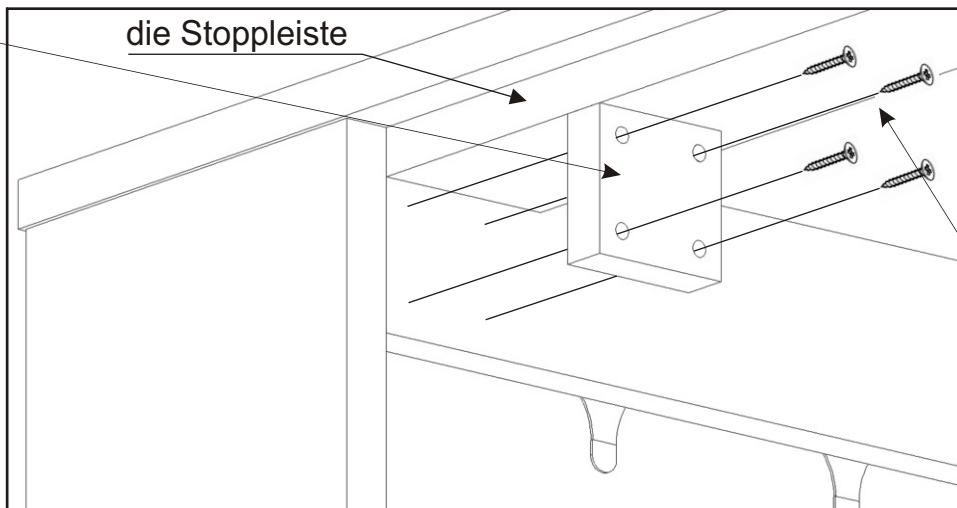

V4x35

8x



die Schrauben-
abdeckung

8x

