

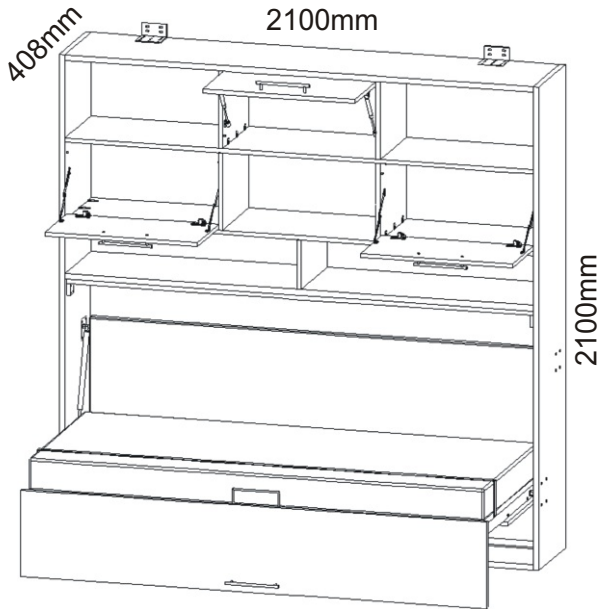











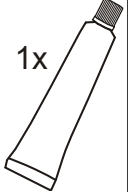
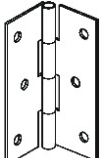

VS 1056P 90 MAX

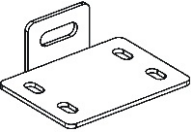
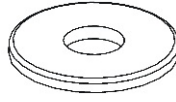
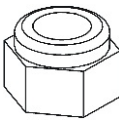
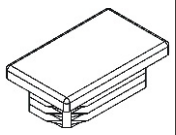
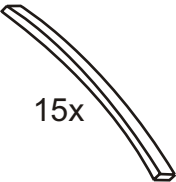
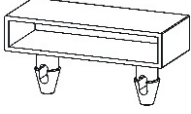

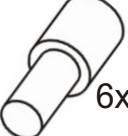
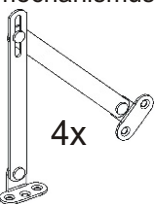

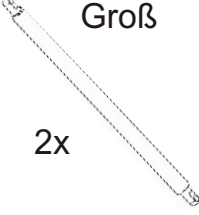
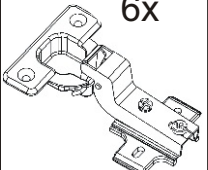

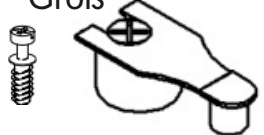

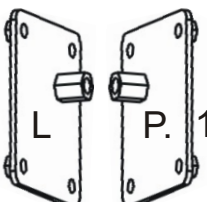
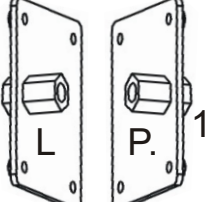
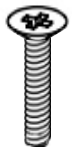
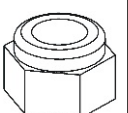

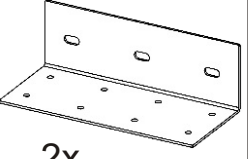
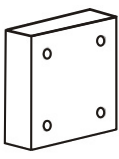

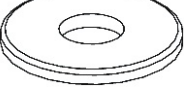
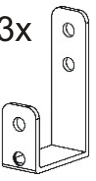

der Kleber 1x 	der Stift 8x35mm 7x 	die Befestigungsschraube 2x 	die Schraubenabdeckung 33x 	Metallkleber 1x 
---	---	---	--	---

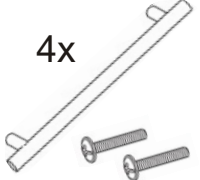
das Türband 60mm 4x 	Die Euroschraube 12x 	die Zierschraube 4x40 8x 	der Senkschraube 4x60 12x 	der Türhalter 50x40x20mm 8x 	die Unterlage M4 20x 	die Mutter M4 20x 	der Deckel 50x30 4x 
---	--	---	---	--	--	--	--

die Lamelle 885mm 15x 	Die Lamellenhalter 30x 	der Nagel 110x 	die Stütze 6x 	der Korbaufhängungsmechanismus 4x 	der Gaskolben klein 120N - 2x 60N - 2x 	der Gaskolben Groß 2x 	das Türband 6x 
---	--	--	---	---	--	---	--

der Verbindungsmechanismus Groß 30x 	der Verbindungsmechanismus klein 44x 	das Absetzblech 80x90 1x L 1x P. 	das Absetzblech 100x120 1x L 1x P. 	M 6x25 die Senkschraube 16x 	die Mutter M8 2x 
---	---	---	--	--	---

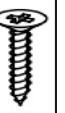
der Winkel 150x85x45 2x 	der Türstopper 2x 	der Gurt 1x 	MDF 3mm 2x 	die Unterlage M13 4x 	der Haken 42x12x24 3x 	V6x70 6x 
---	---	---	--	--	--	--

der Halter 192mm 4x 	der Dübel Ø12 6x 	M8x25 2x 	M12x70 2x 	V4x17 36x 	V4x20 16x 	V4x16 28x 	V3,5x16 26x 	V4x35 15x 
---	---	--	---	---	---	---	---	---

1.

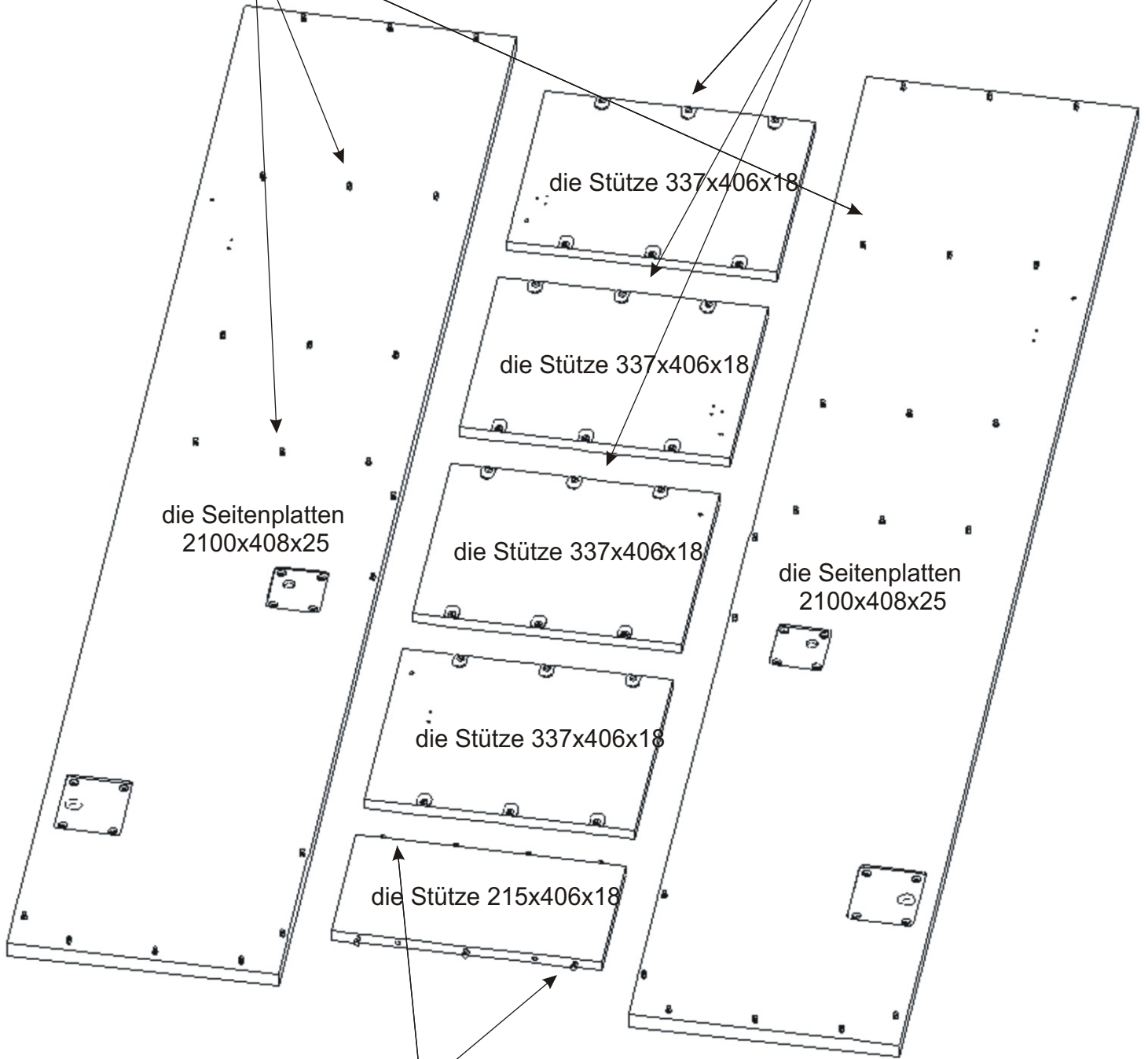
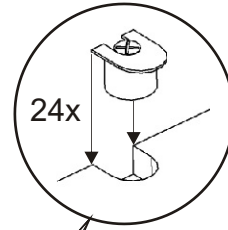
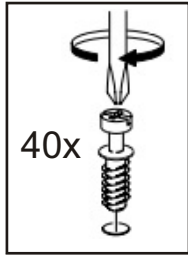

2.

Es ist wichtig, die Verbindungsmechanismen auf beiden Seiten gleichzeitig zu klopfen, um ein Brechen zu vermeiden.

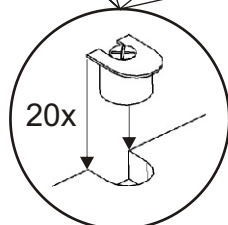
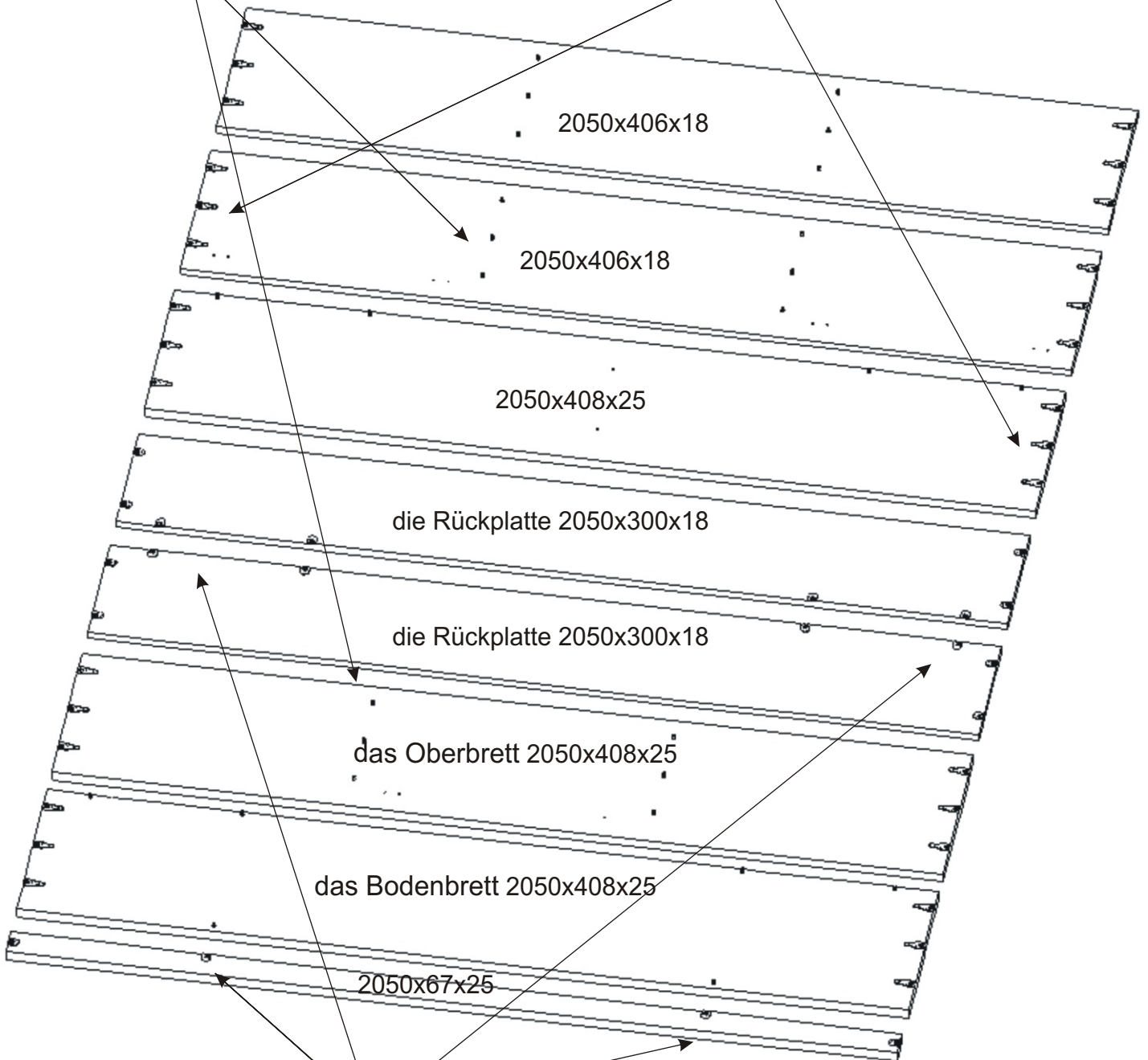
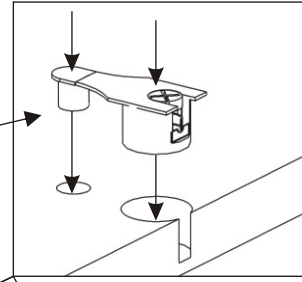
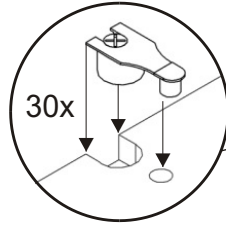
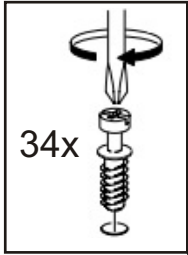

3.

der Halter
192mm

3x



die Tür 666x330x18

die Tür 666x330x18

die Tür 666x330x18

V4x16

12x



V3,5x16

4x

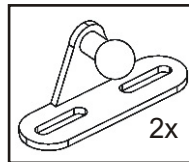
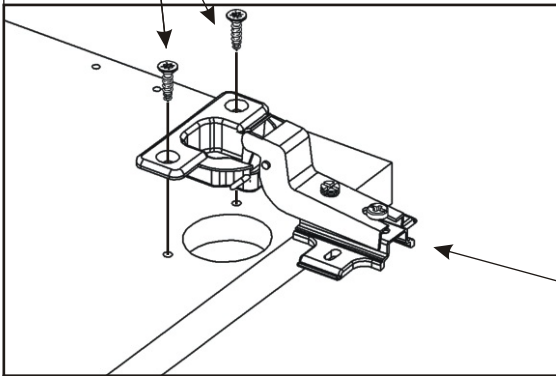

2x

das Türband

6x

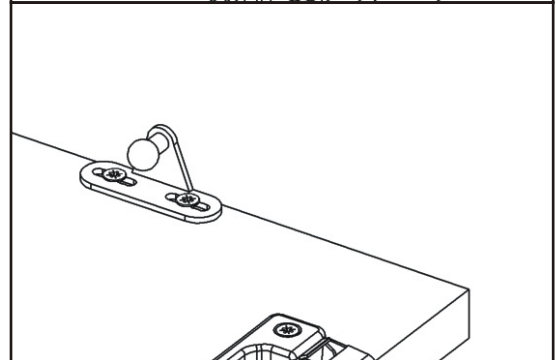
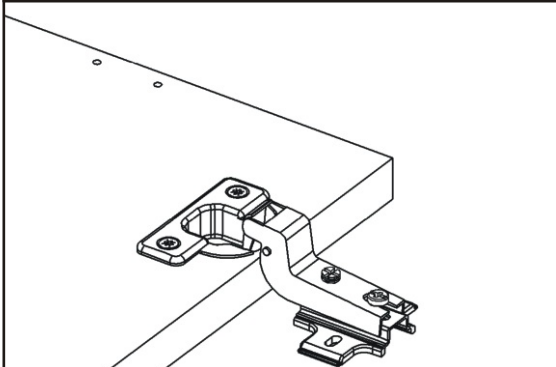
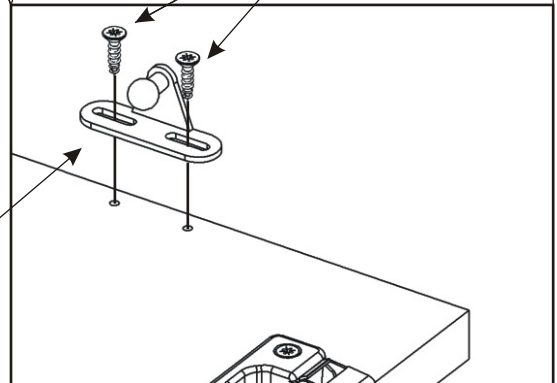
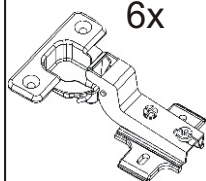

4.

der Kleber

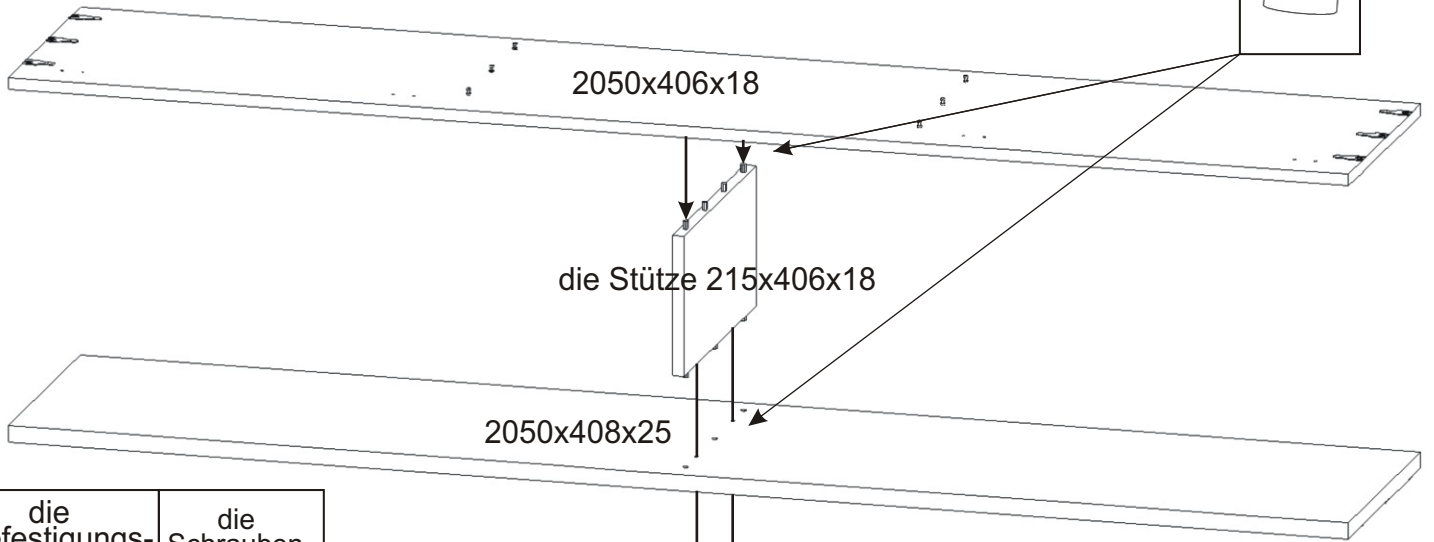

die Befestigungsschraube	die Schraubenabdeckung
2x	2x

5.

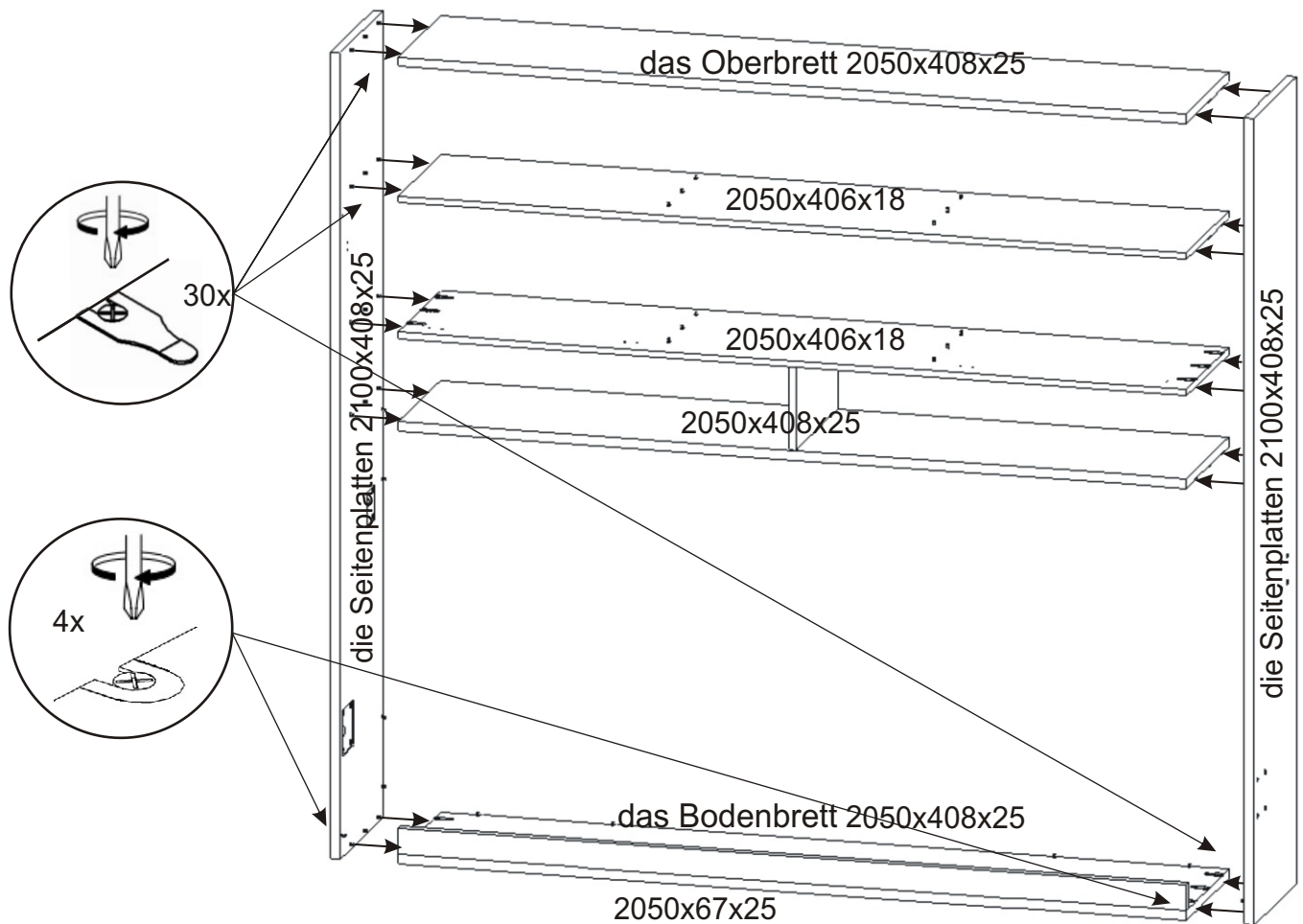

6.

die Stütze
337x406x18

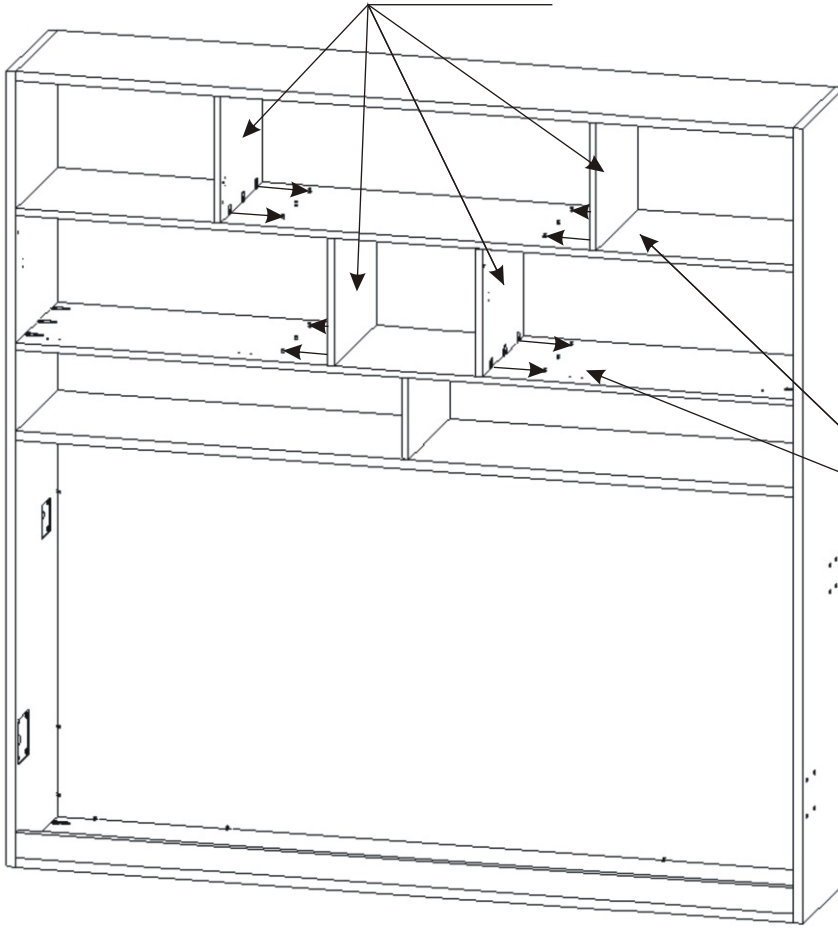

24x

7.

die Rückplatte 2050x300x18

die Rückplatte 2050x300x18

16x

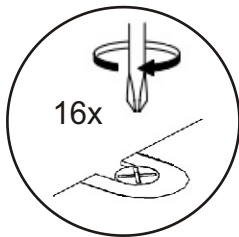

8.

Messen und richten Sie die Diagonalen aus, bevor Sie die Rückseite des Schrankes anbringen.

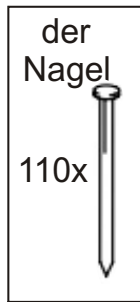
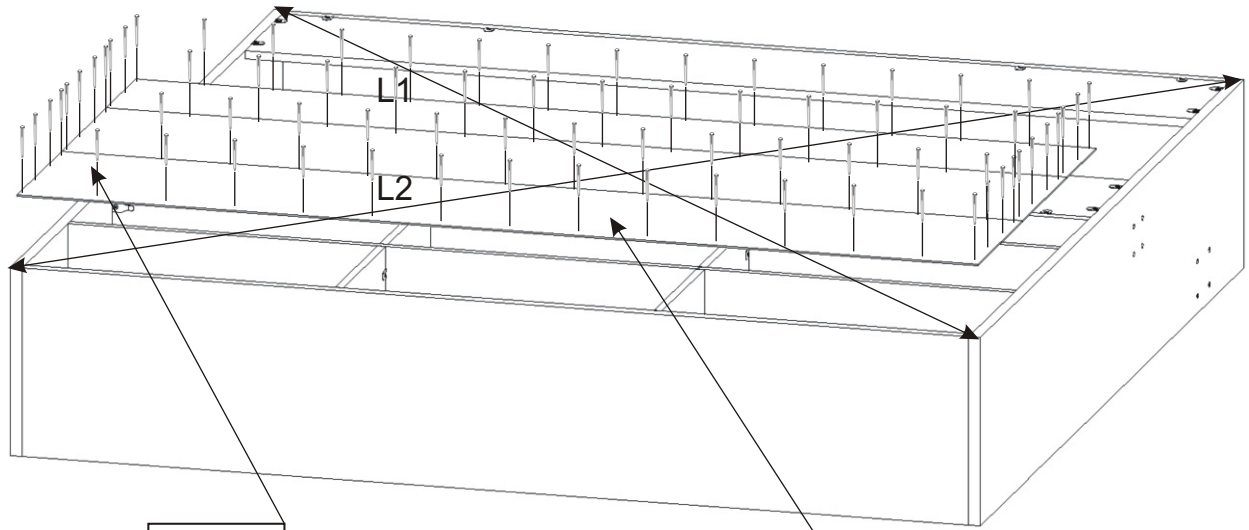

MDF 2080x235x3 1x
MDF 2080x355x3 2x

9.

Heben Sie den Körper des Bettes mit einem Kollegen an.

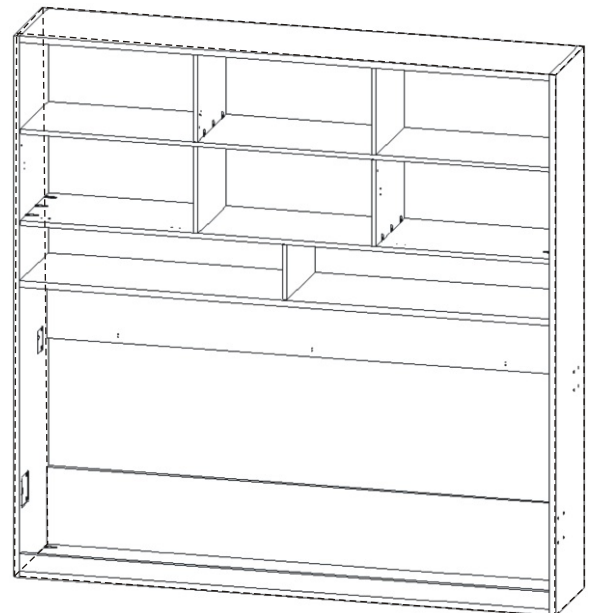
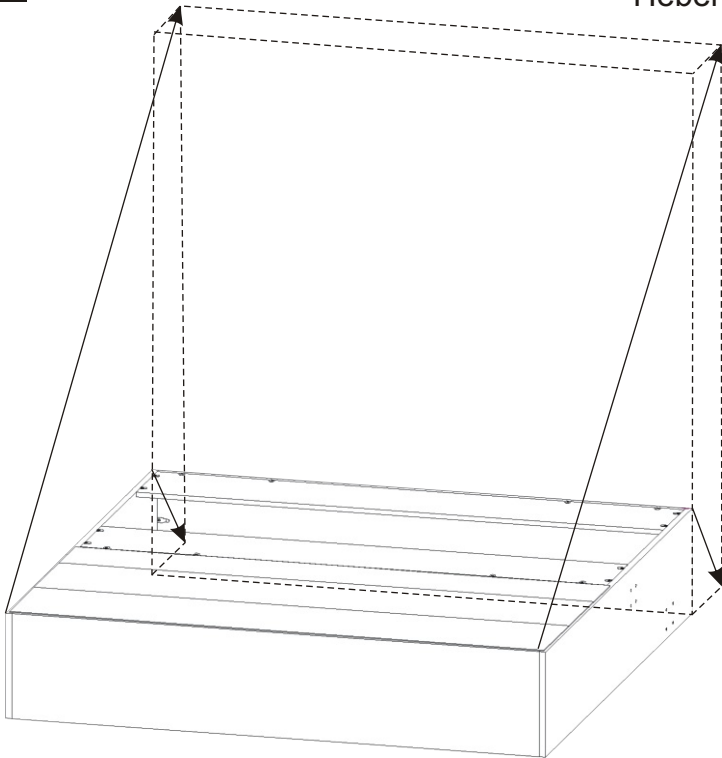

10.

10.1. die Rückplatte 2050x300x18

V4x16

6x



der Haken
42x12x24

3x

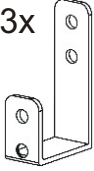

10.2.

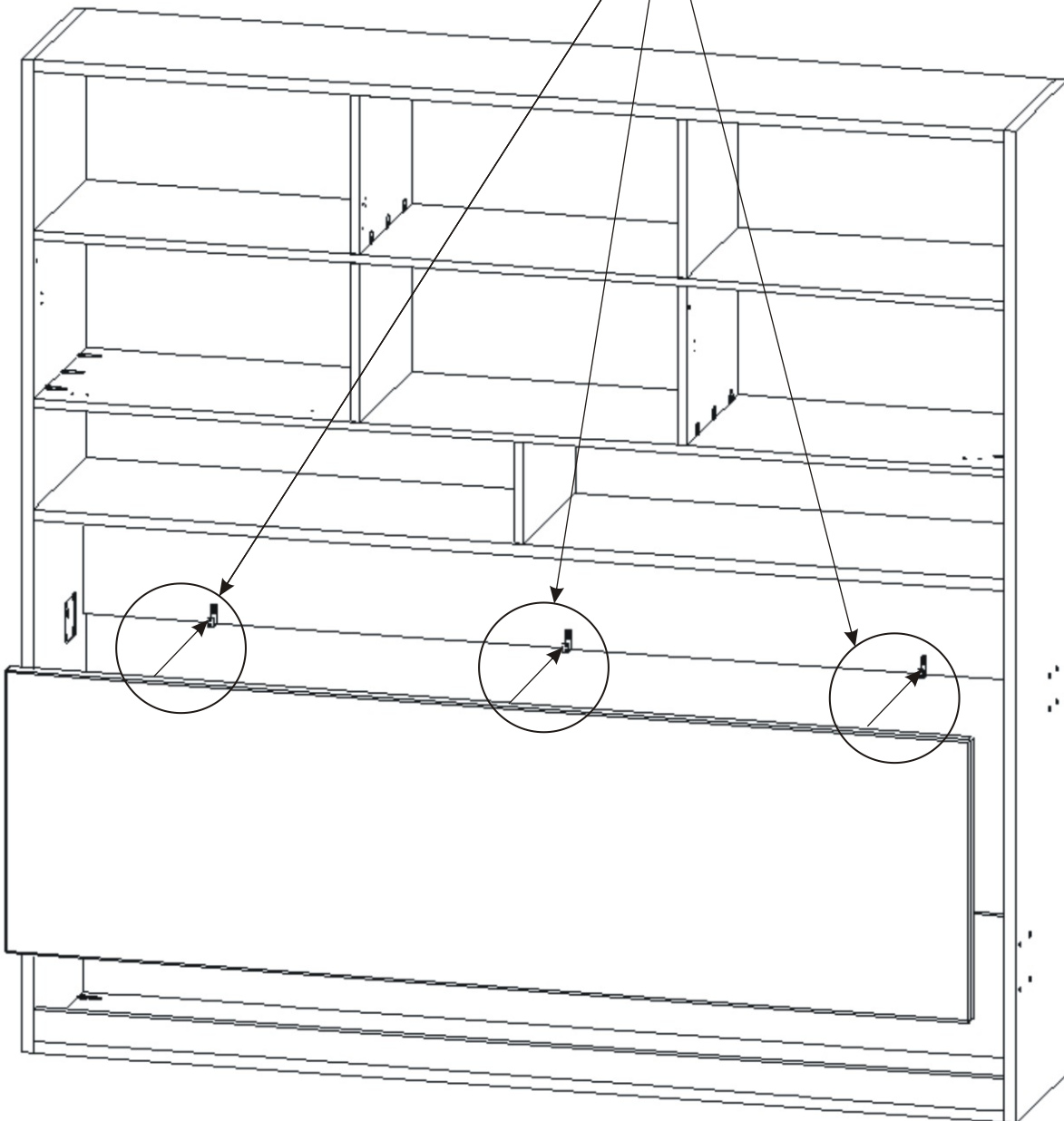
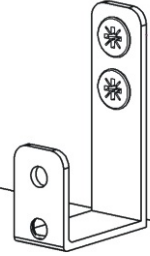

11.

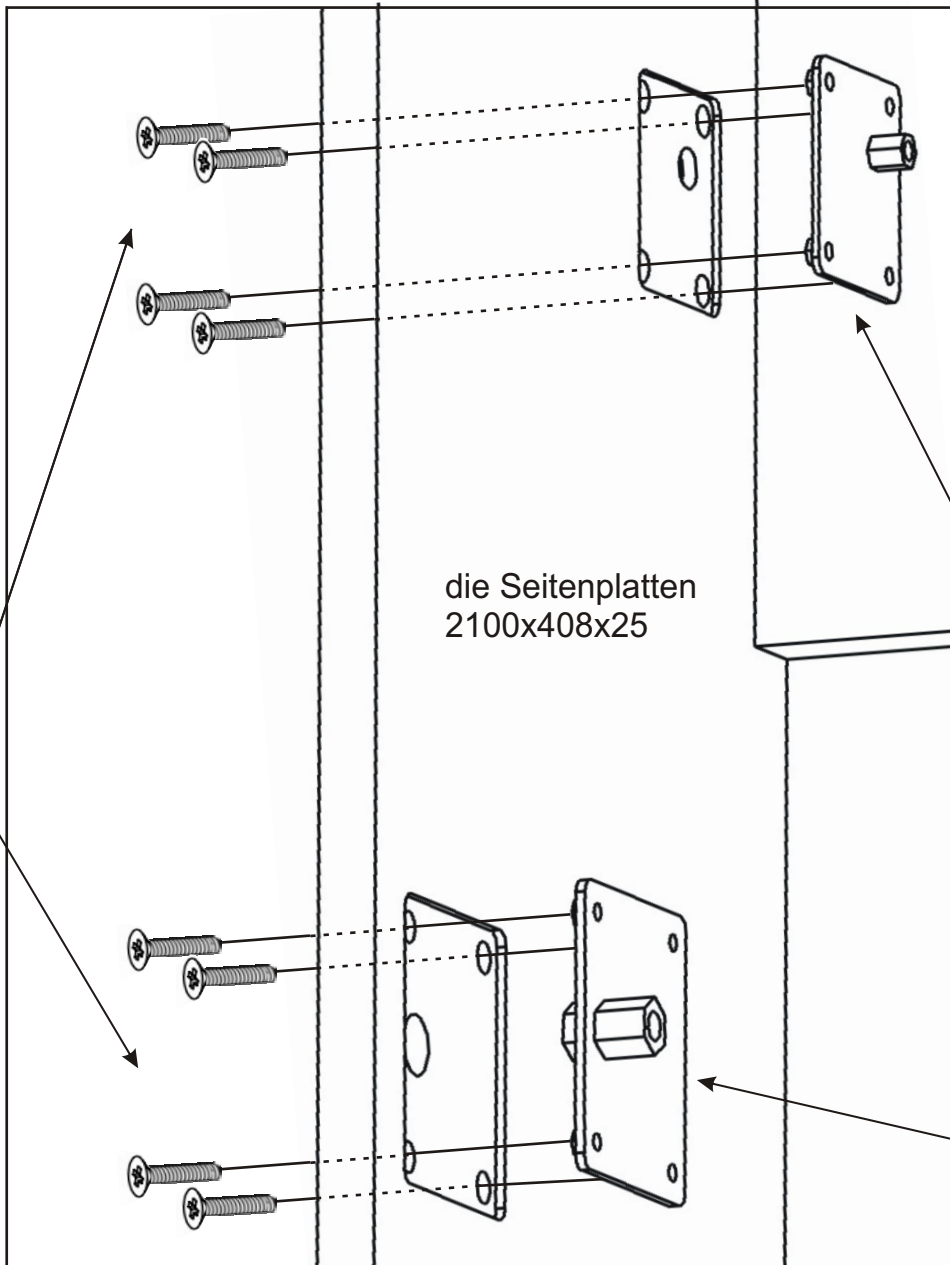
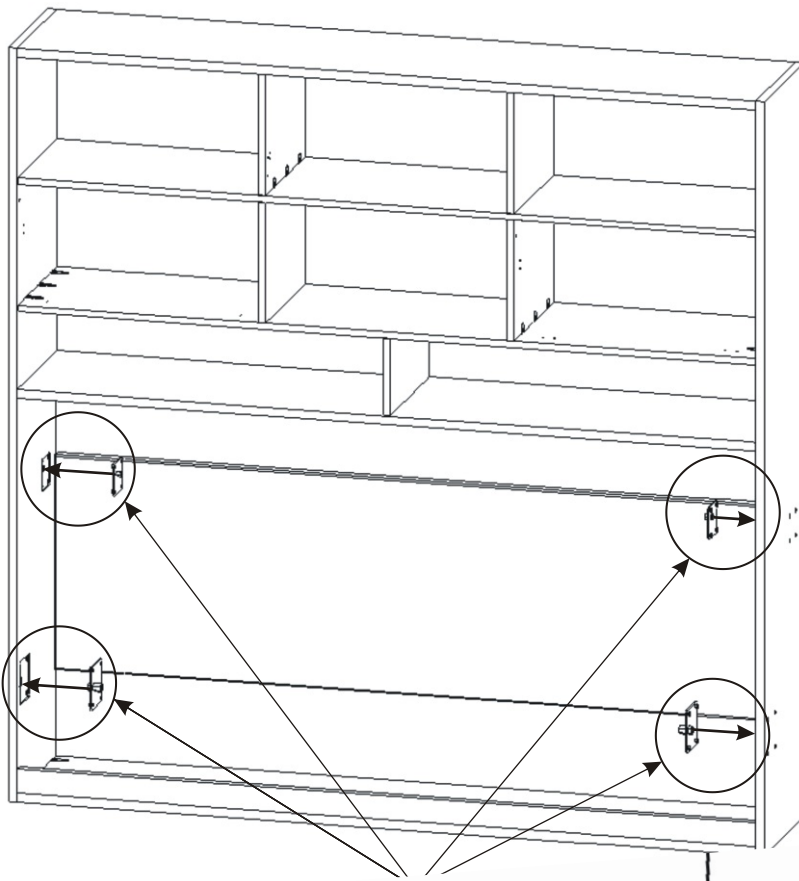

M 6x25
die Senks-
schraube

16x

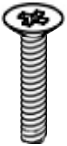

die
Schrauben-
abdeckung

16x



die Seitenplatten
2100x408x25

das Absetz-
blech
80x90

2x

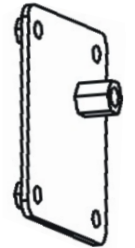

das Absetz-
blech
100x120

2x

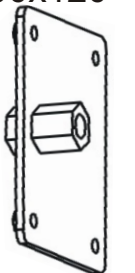

Das Klappbett muss vor der Montage des Metallrosts an der Wand befestigt werden. Andernfalls besteht beim Öffnen Absturz- und Verletzungsgefahr!

Die Anzahl und die Art der Dübel müssen je nach Wandtyp bestimmt werden.

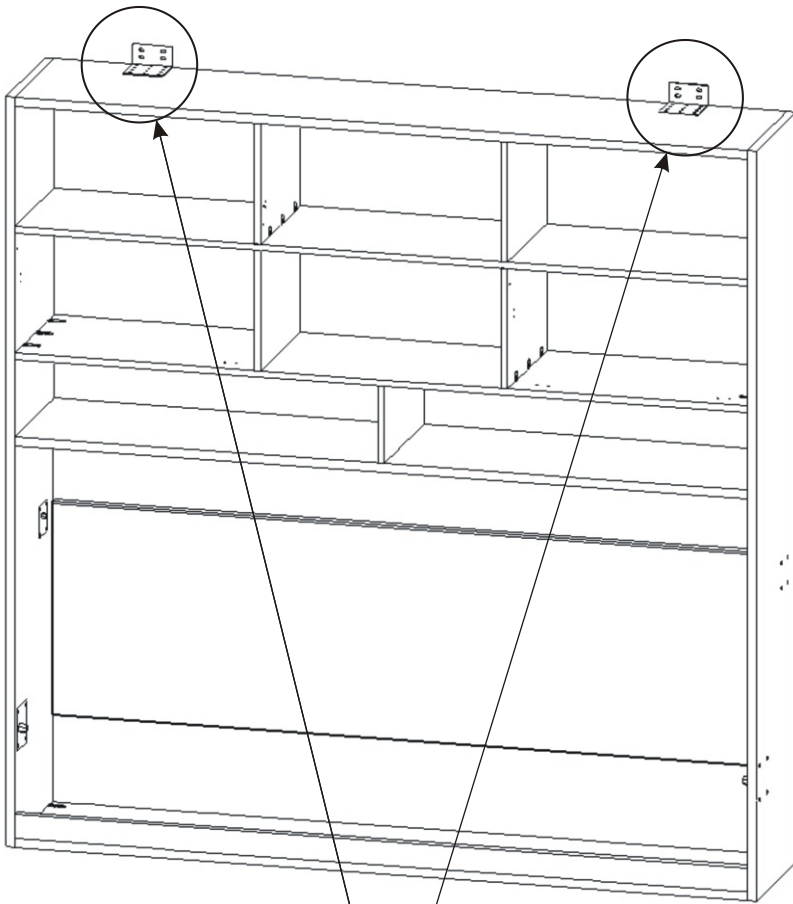

V4x20

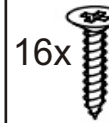

16x

der Dübel
ø12x60

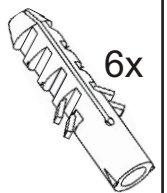

6x

der Winkel
150x85x45

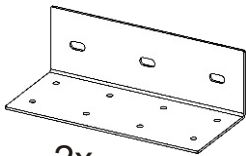

2x

V6x70



6x

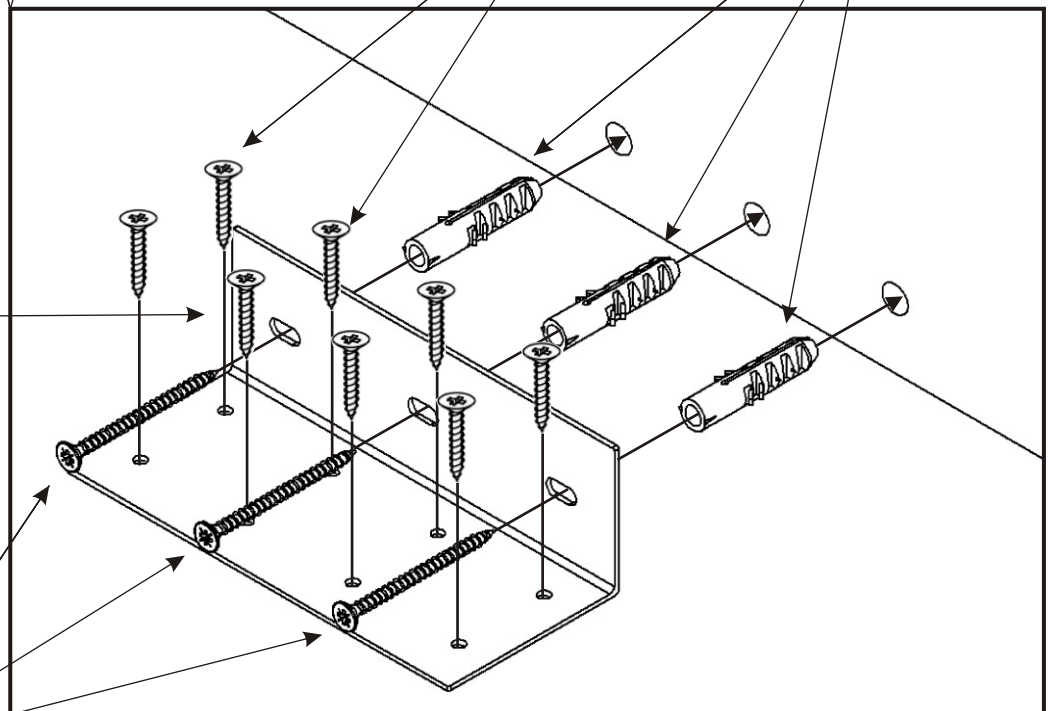

13.1.

die Stütze 337x406x18

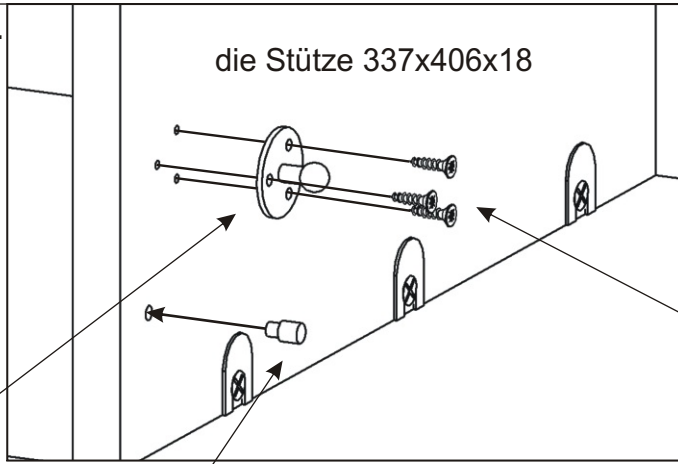

13.2.

die Tür 666x330x18

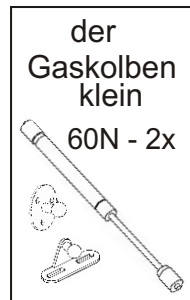
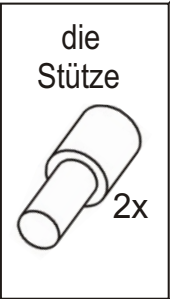
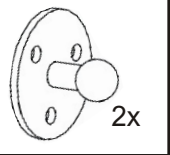
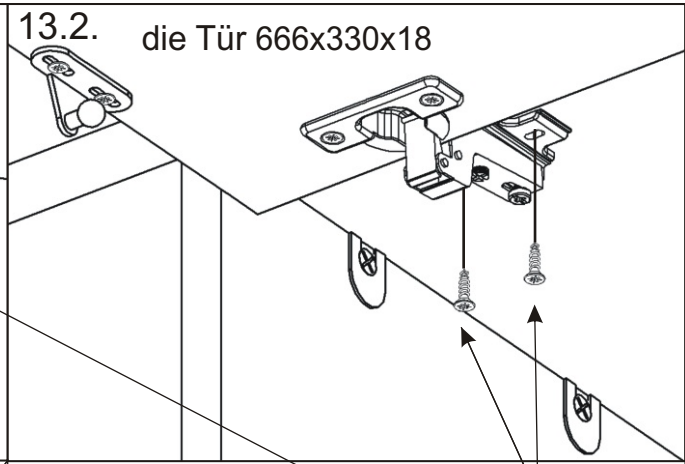

V3,5x16

6x



V4x16

4x

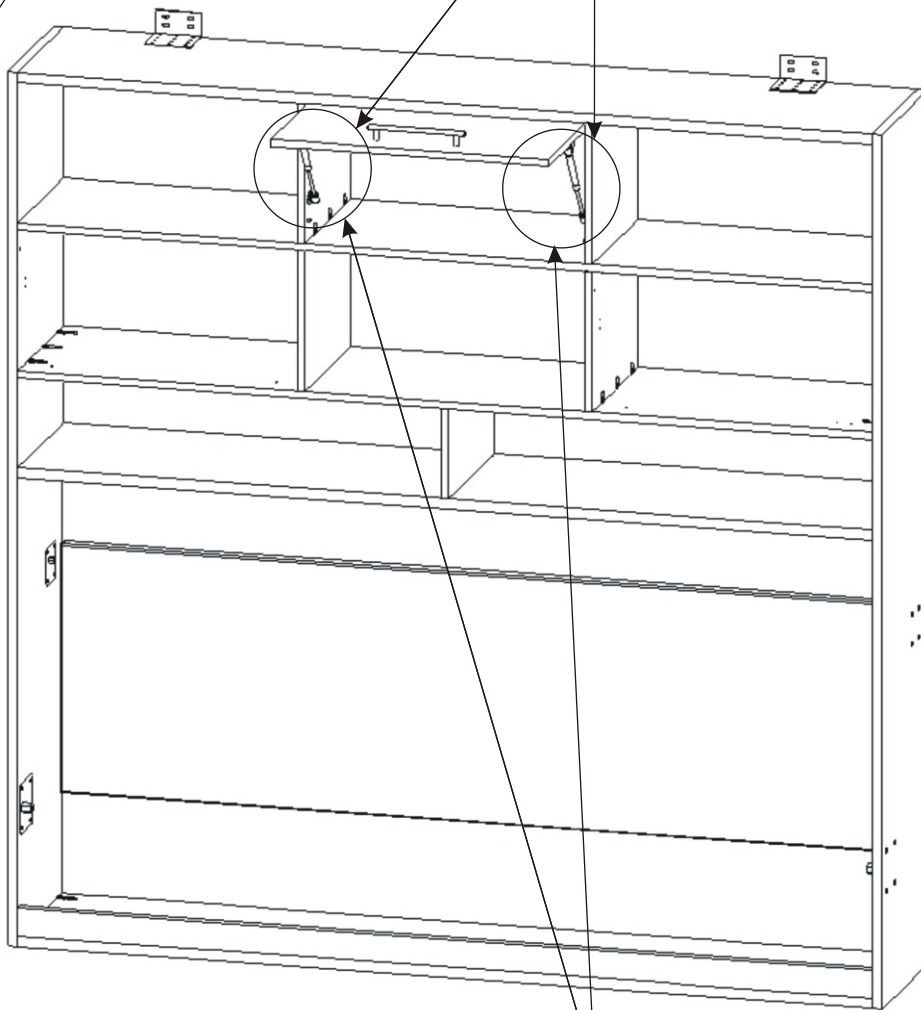

13.3.

das Oberbrett 2050x408x25

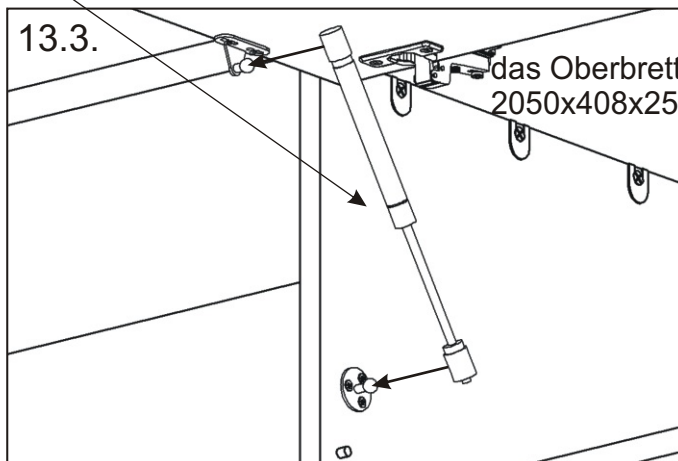

13.4.

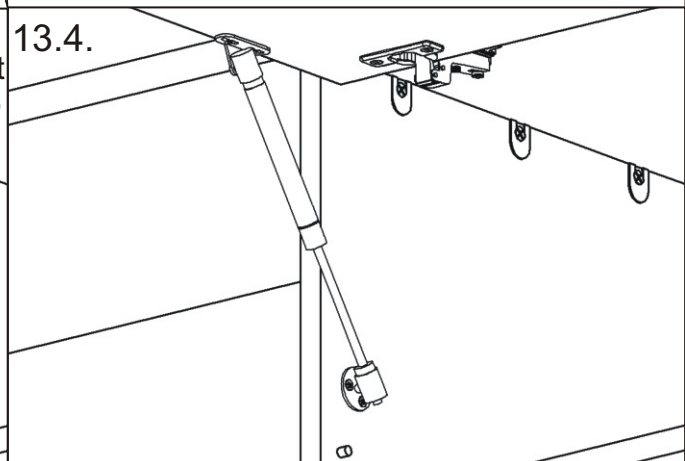

14.1.

2050x406x18

14.2.

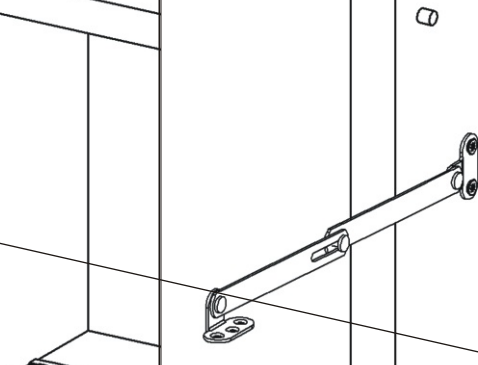
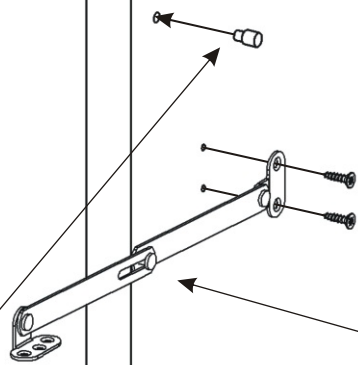

die Stütze

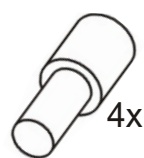

4x

V3,5x16

8x



der Korbaufhängungsmechanismus

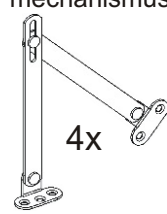

4x

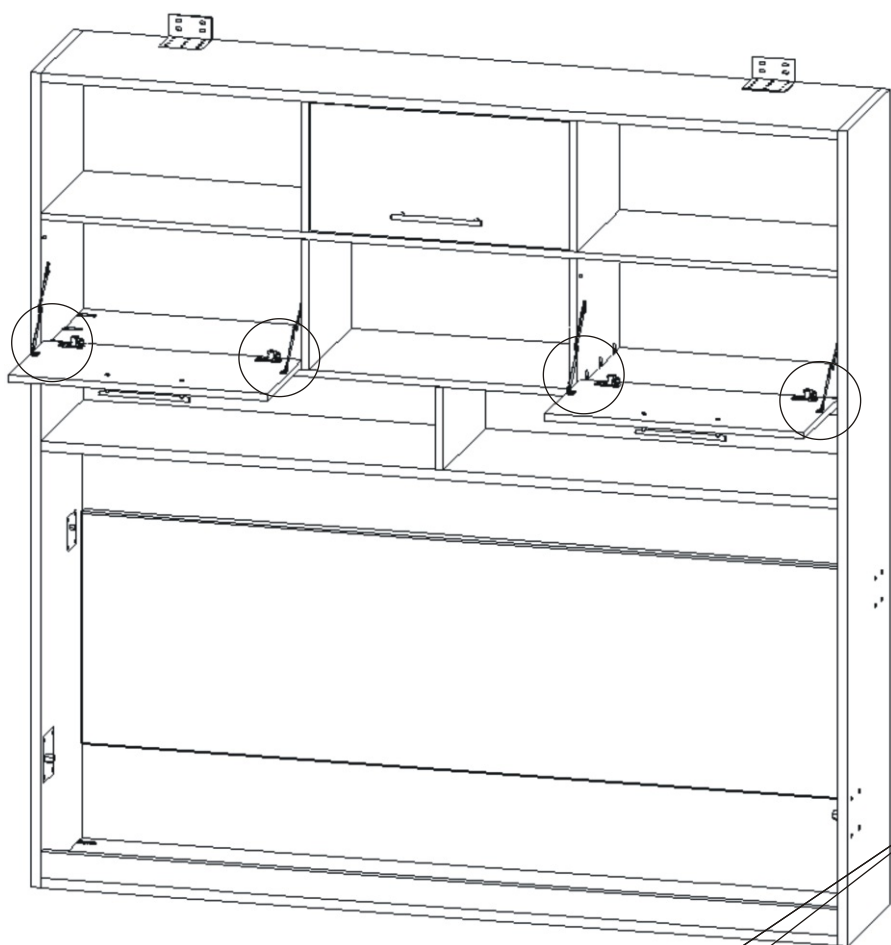

V4x16

6x



V3,5x16

8x



14.3.

14.4.

die Tür 666x330x18

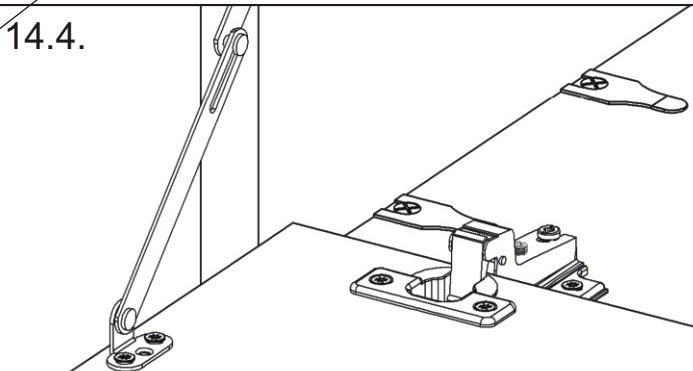
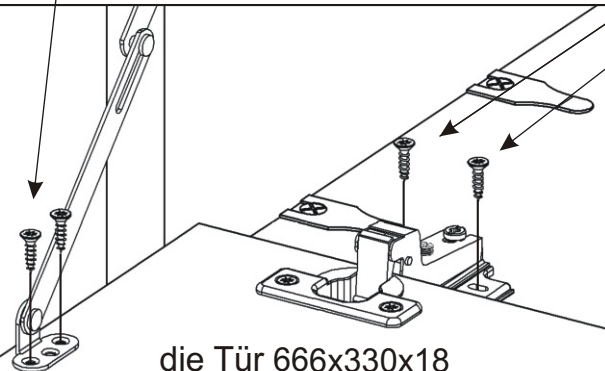

15.

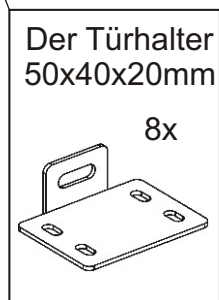
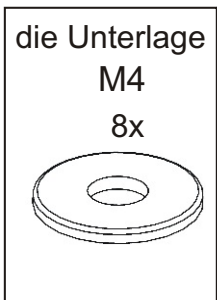
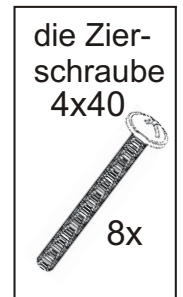
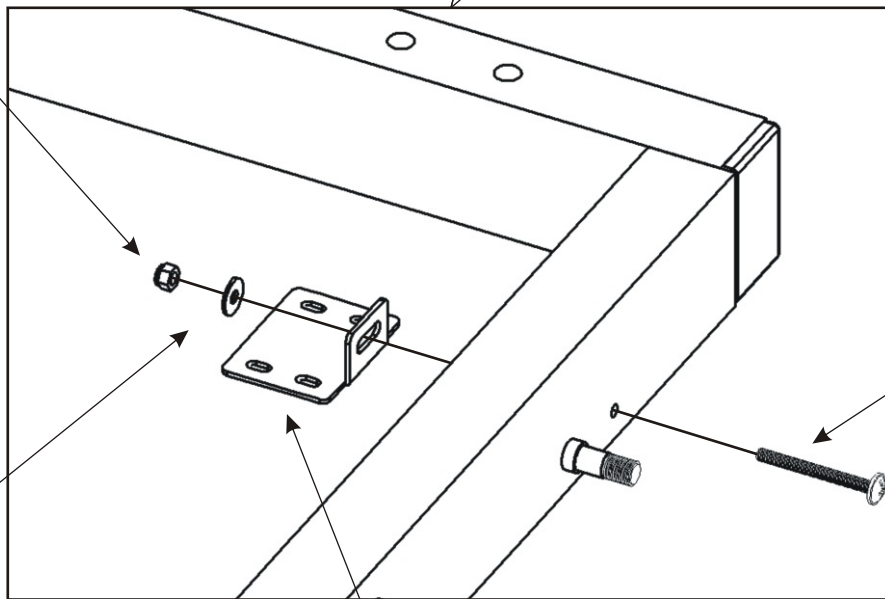
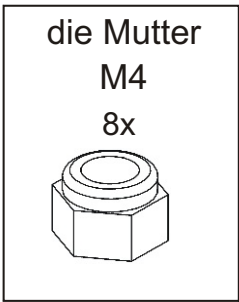
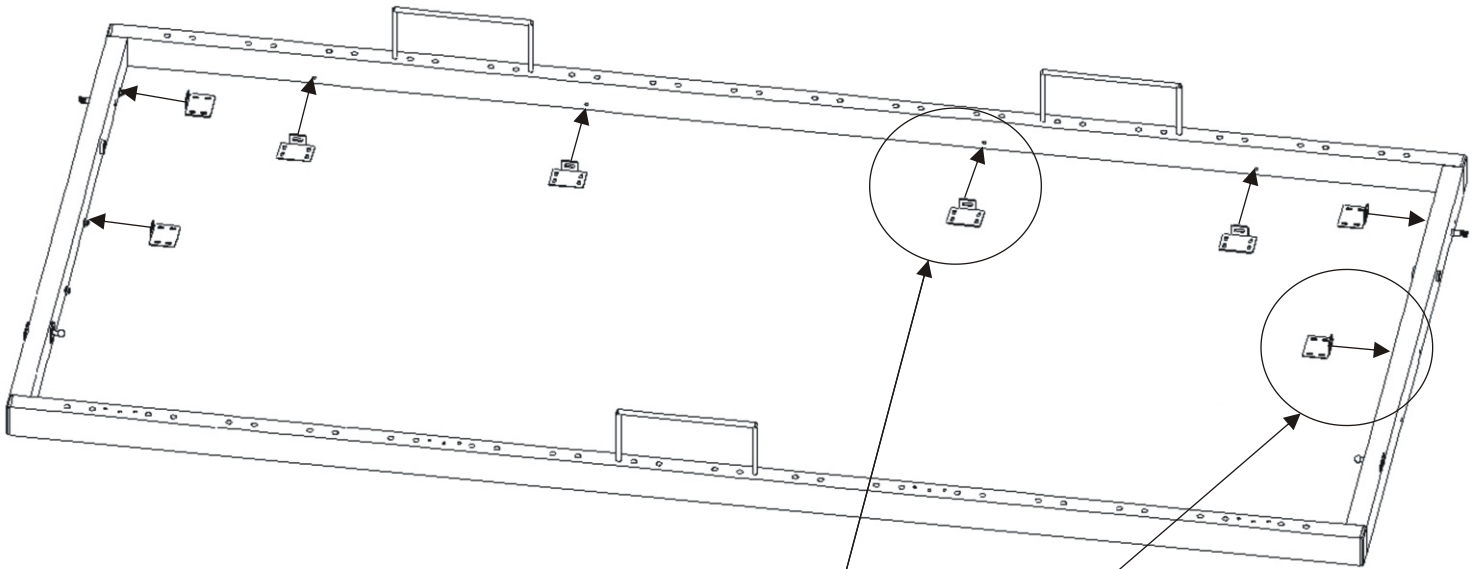

16.

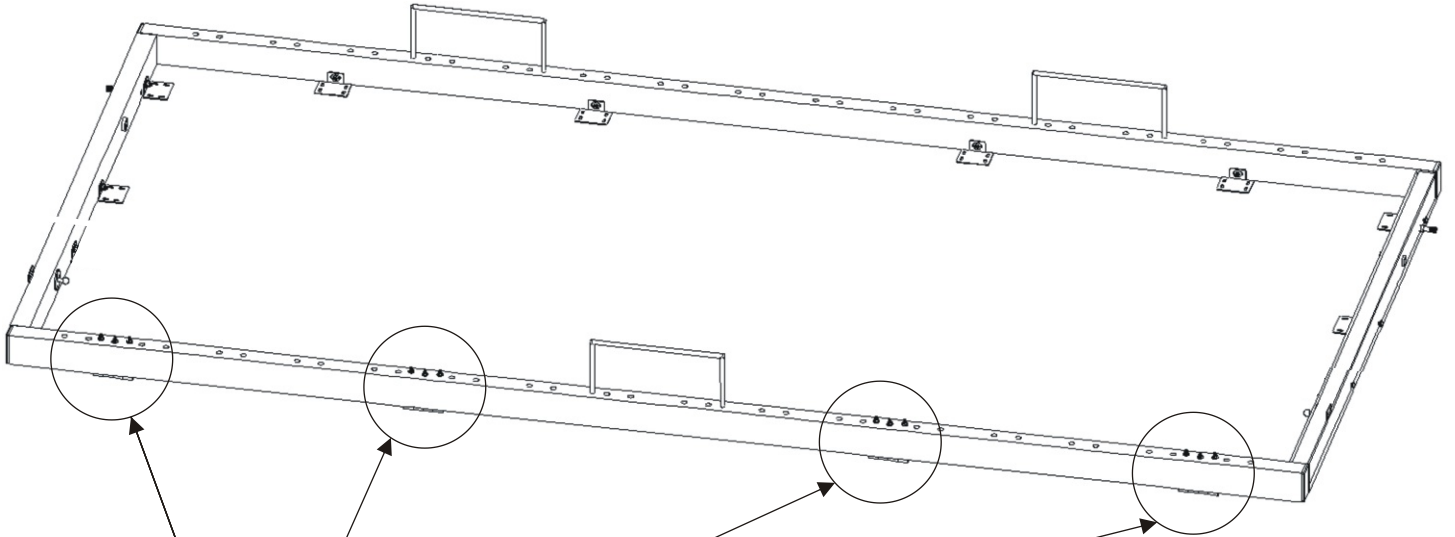

die Mutter
M4
12x

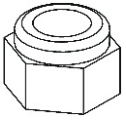

die Unterlage
M4
12x

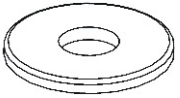

das Türband
60mm

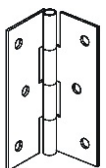

4x

der Senkschraube
4x60



12x

der Deckel
50x30
4x

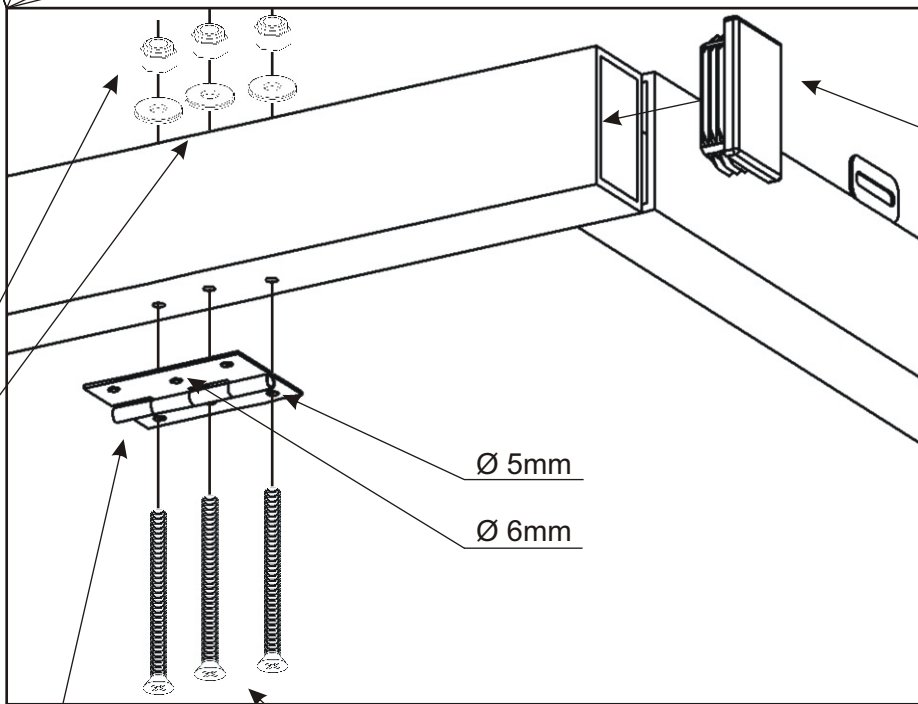
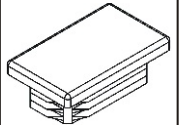

17.

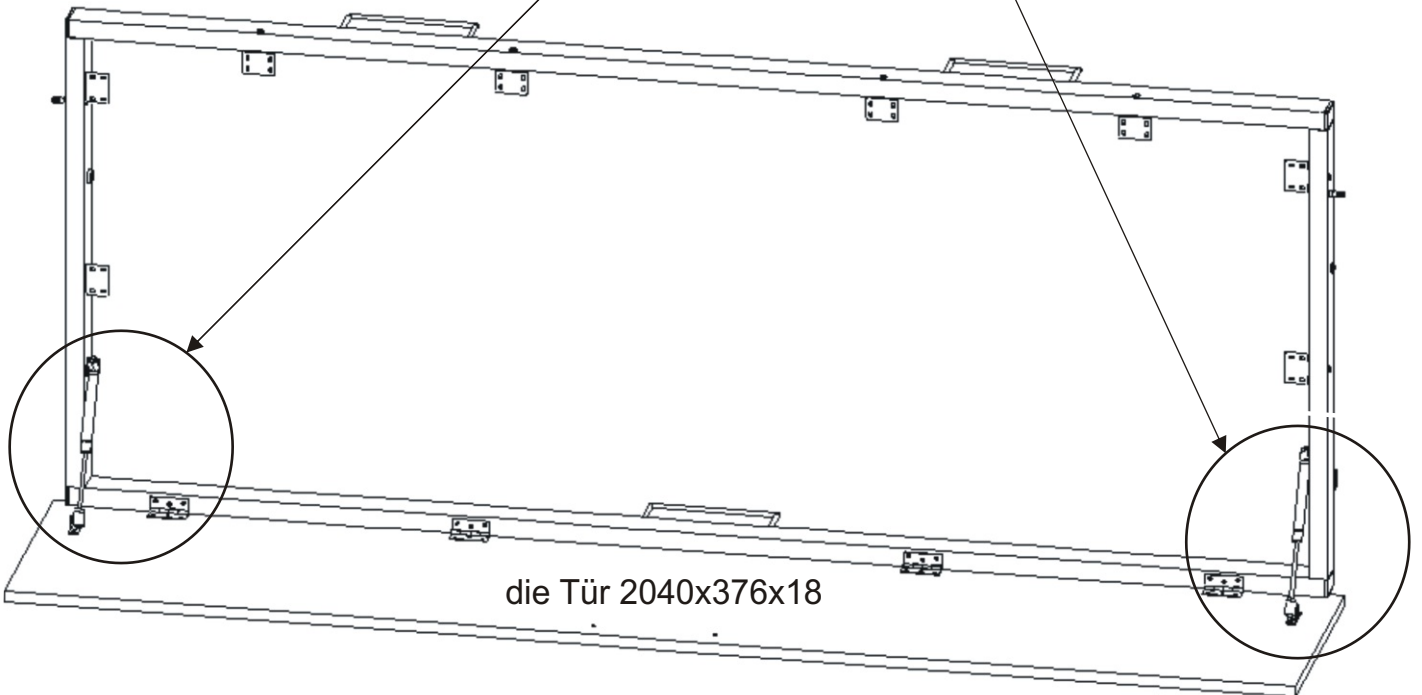
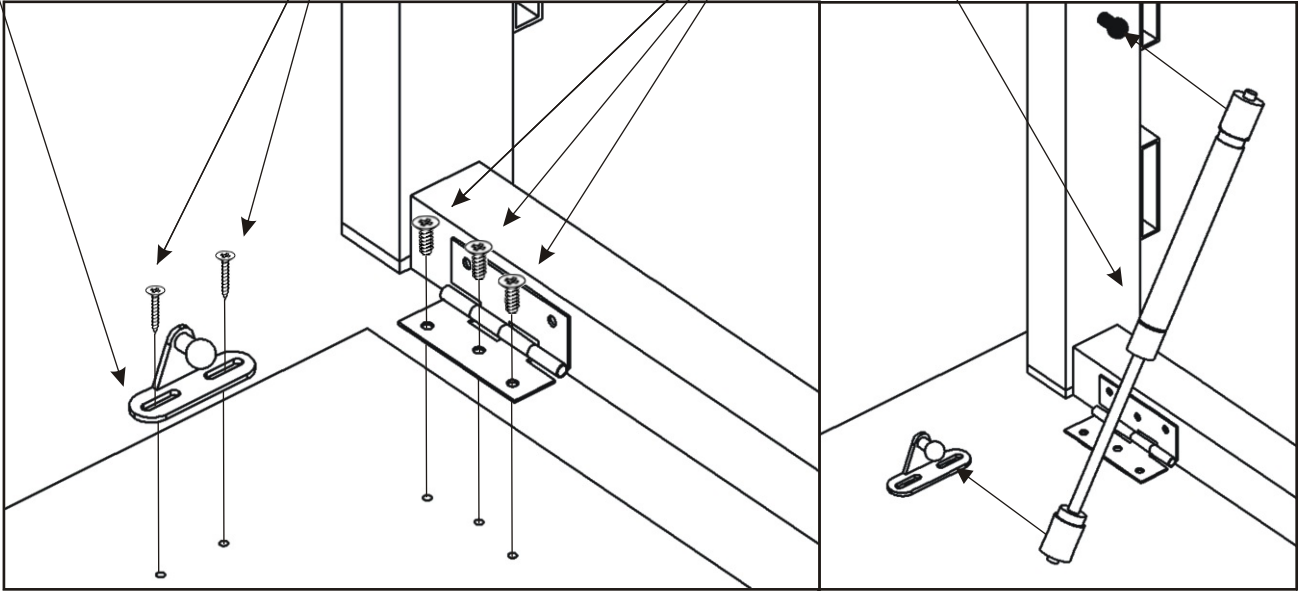
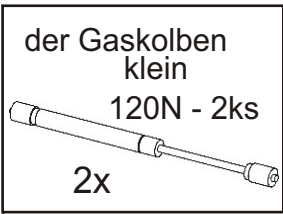
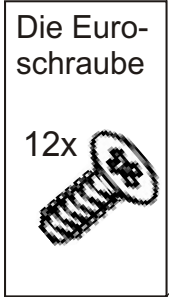
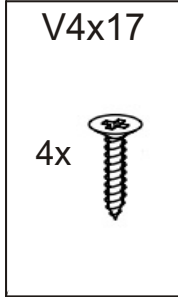
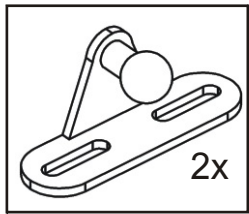

18.

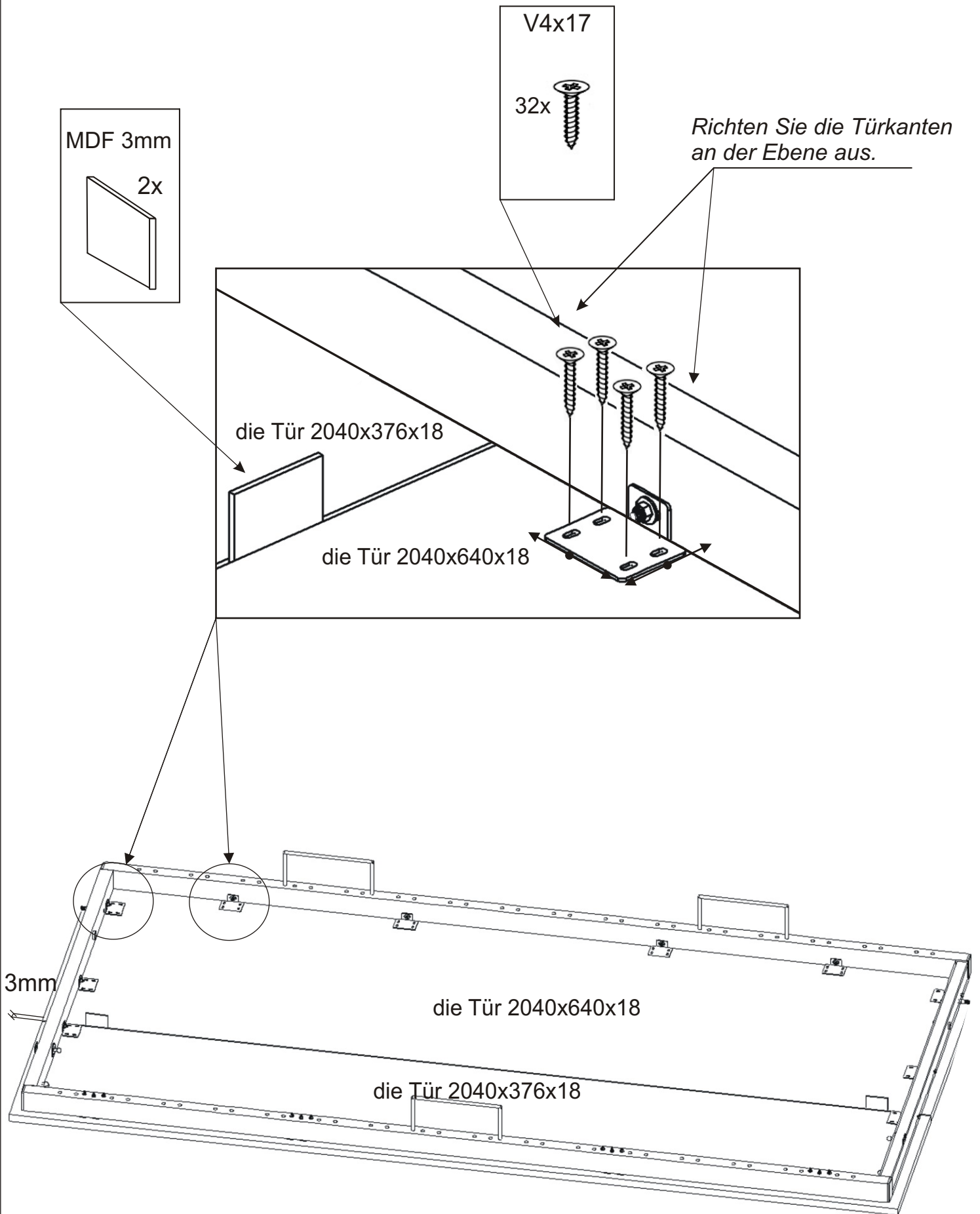

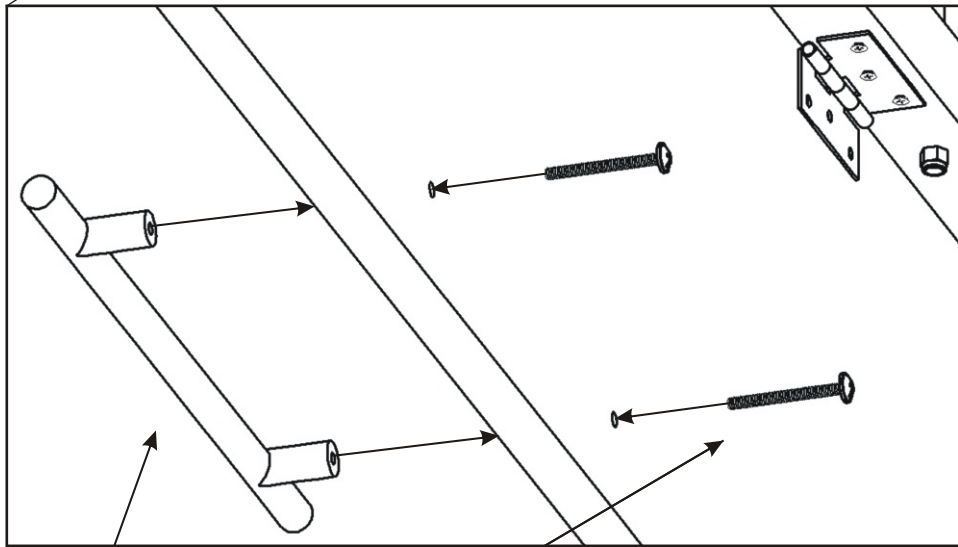
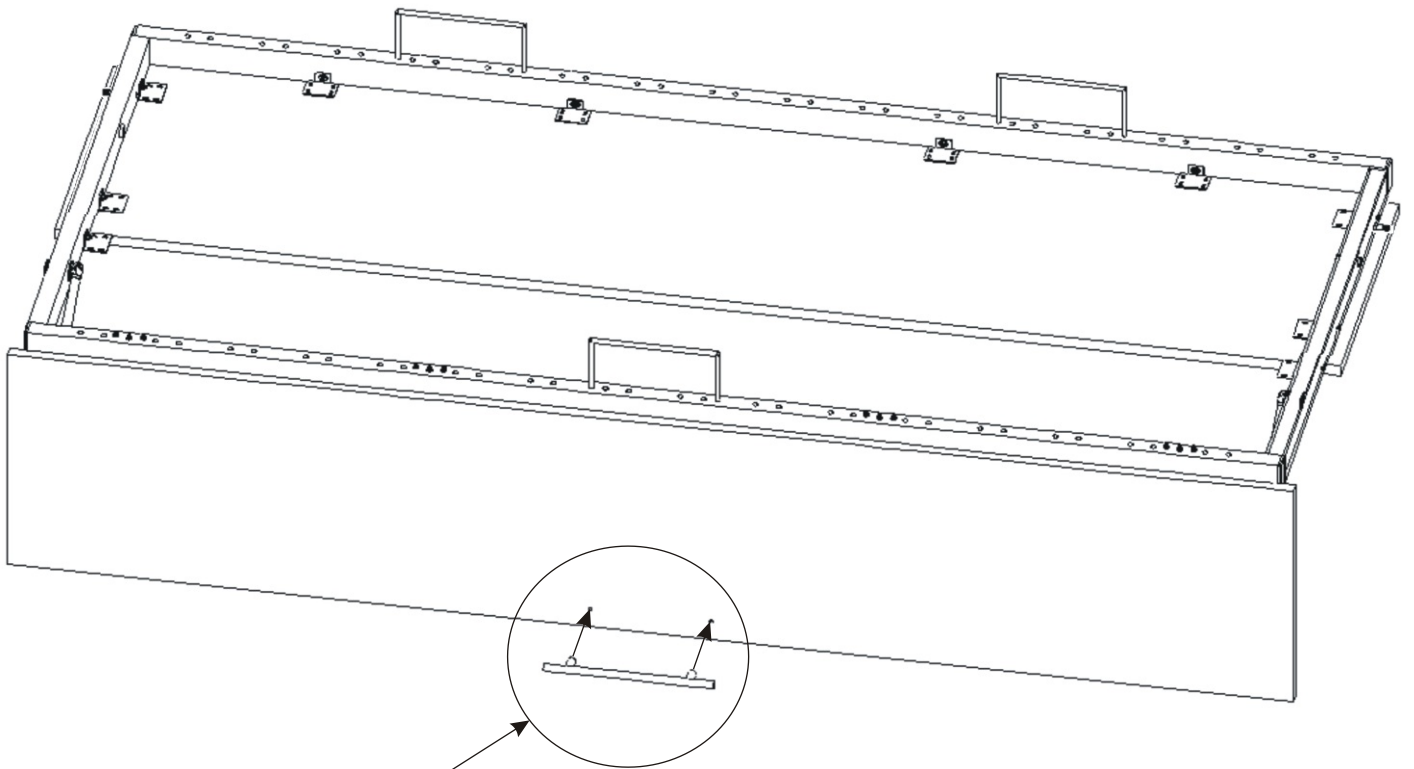

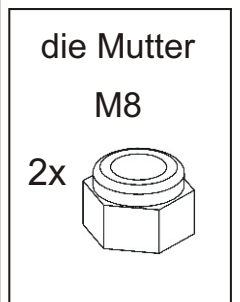
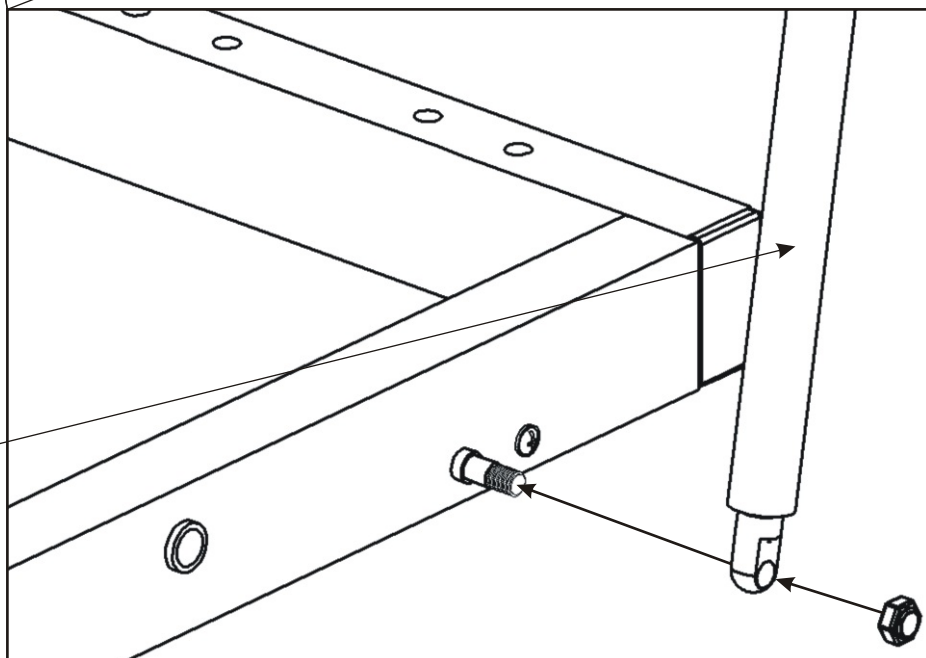
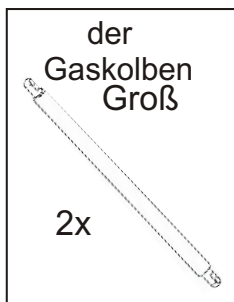
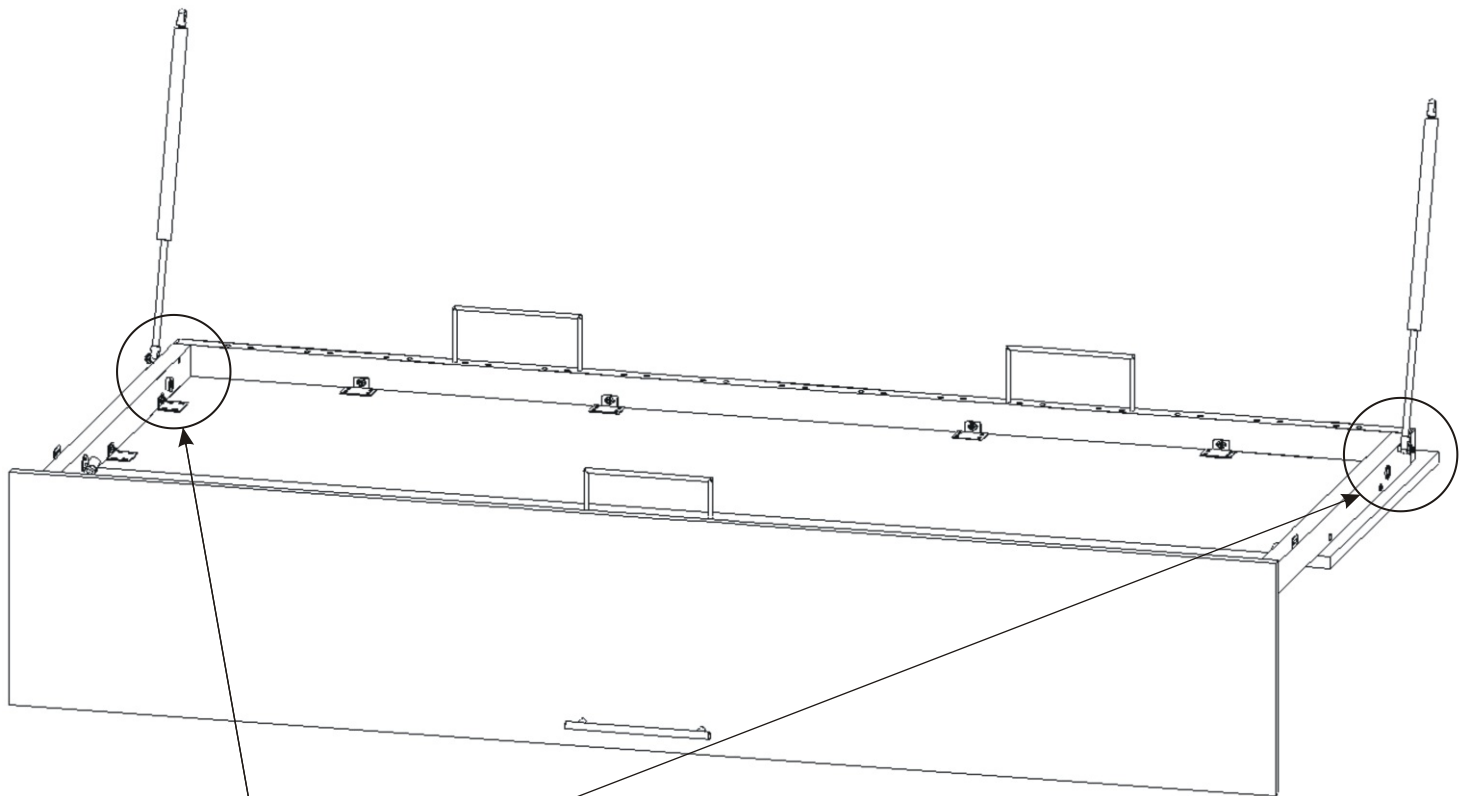

Der große Kolben ist am Rahmen zu montieren und mit einer Mutter zu sichern. Die Mutter darf nicht vollständig angezogen werden, um die notwendige Beweglichkeit des Kolbens zu gewährleisten. Bei unsachgemäßer Fixierung besteht die Gefahr einer irreversiblen Beschädigung des Kolbens.

21.

1. Schieben Sie den Rahmen mit einem Kollegen in den Korpus.
2. Schrauben Sie den Bettrahmen mit einer M12x70-Schraube und einer Unterlegscheibe an die Bodenplatte des Bettkörpers an.

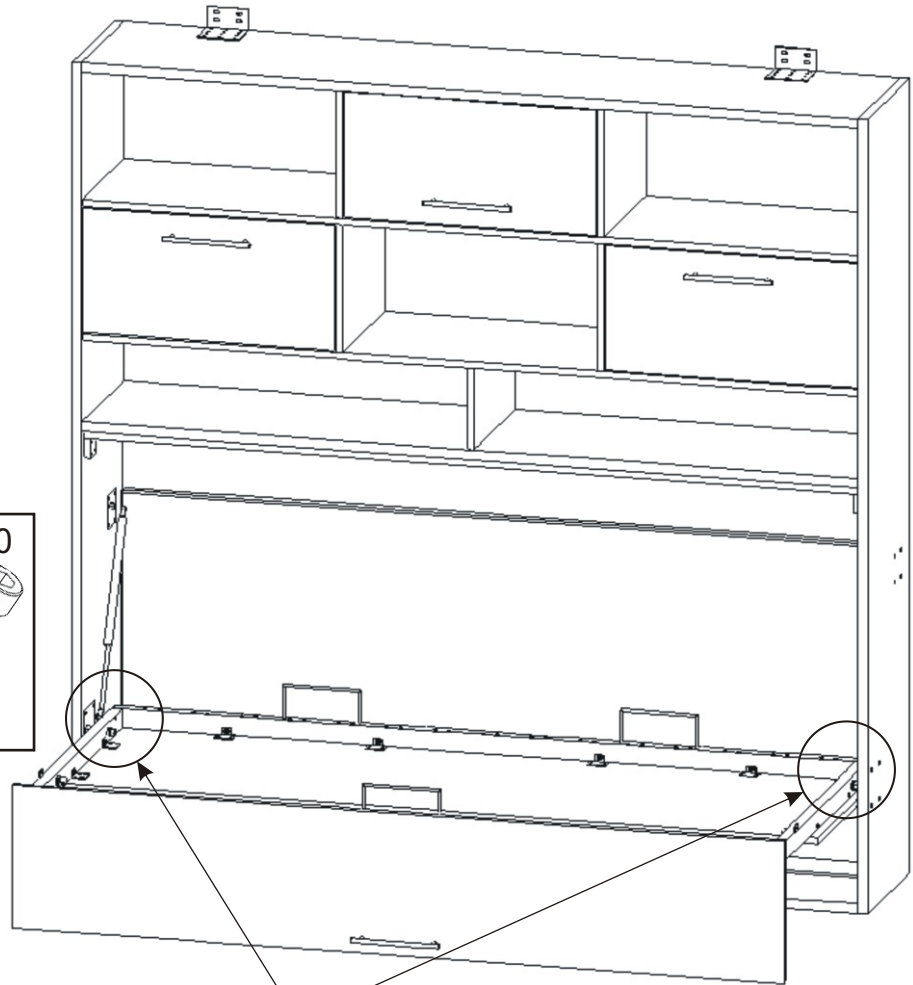

die Unterlage
4x M13

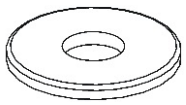

M12x70

2x



21.1.

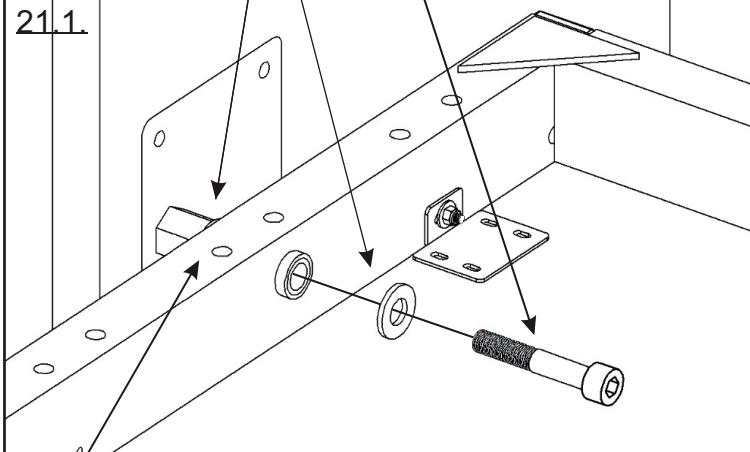

21.2.

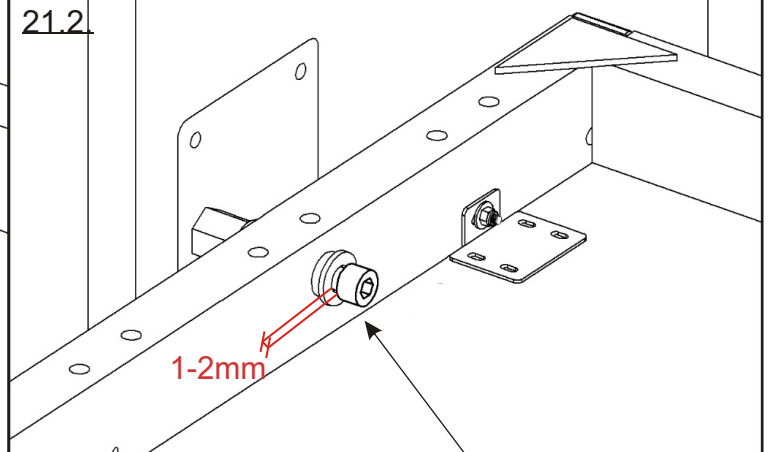

1-2mm

Metall-
kleber
1x

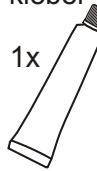

Geben Sie etwas Klebstoff auf die Befestigungsplatte an der Bettseite und schrauben Sie die Schraube M12x70 sofort fest. Sollte das Bett später wieder demontiert werden, lässt sich die Schraube mit etwas mehr Kraft lösen.

Es ist außerdem notwendig, von Zeit zu Zeit zu überprüfen, ob sich die Schraube nicht gelöst hat.

Ziehen Sie die Schraube M12 x 70 nicht vollständig fest. Lassen Sie zwischen Schraubenkopf und Unterlegscheibe ein Spiel von ca. 1–2 mm, um die notwendige Beweglichkeit zu gewährleisten. Wird die Schraube zu fest angezogen, besteht die Gefahr einer irreparablen Beschädigung des Bettrahmens!

22.

Die Kolben werden bei geschlossener Tür montiert.
Die obere Anschlagstange darf nicht montiert werden.
2050x70x25mm.

- 1) Die Türen in die horizontale Position kippen und den gesamten beweglichen Teil nach innen drücken.
- 2) Nun die Kolben lose in die oberen Bolzen einsetzen.

Die Schraube darf nicht vollständig festgezogen werden, da sie ein geringes Spiel für die Drehbewegung haben muss. Andernfalls besteht die Gefahr einer irreparablen Beschädigung des Kolbens!

22.1.

22.2.

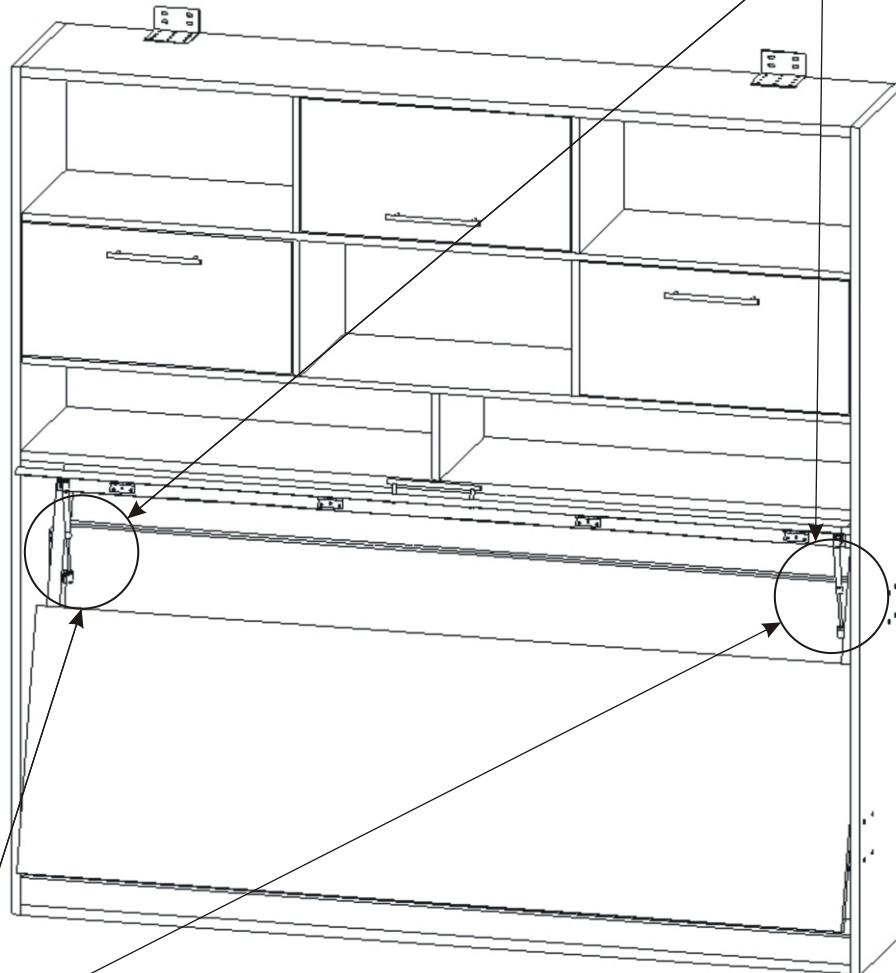

M8x25

2x

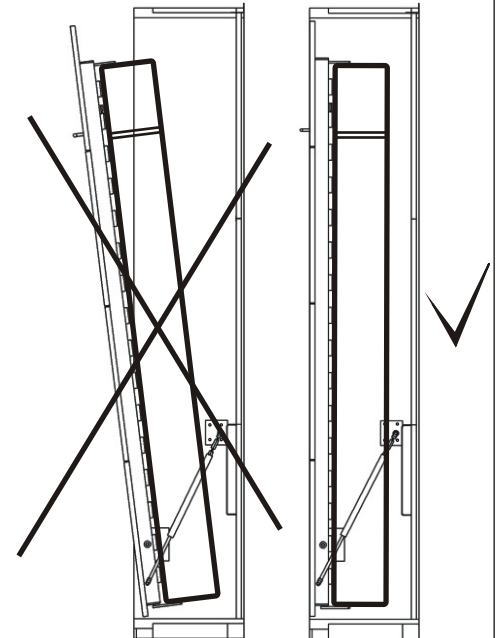

Die Einstellung des Abstands der Kolben

Zur Montage des Klappbettes verwenden Sie die Kolben, die als in der Abbildung A eingestellt sind.
Wenn sich die Tür mit der Matratze nicht übereinstimmt, stellen Sie den Kolbenabstand ein, in dem Sie ihn leicht um ca. 1 bis 2mm öffnen. Maximal 2mm!!!
Wenn Sie einen größeren Abstand einstellen, werden die Kolben dauerhaft beschädigt. Dieser Schaden werden von der Reklamation abgedeckt.

Ⓐ

Ⓑ

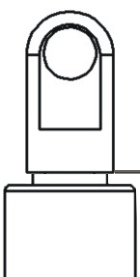

0mm

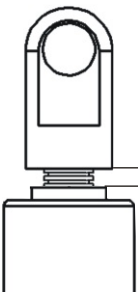

2mm

Befestigen Sie die Stoppleiste 20mm von der Vorderkante.

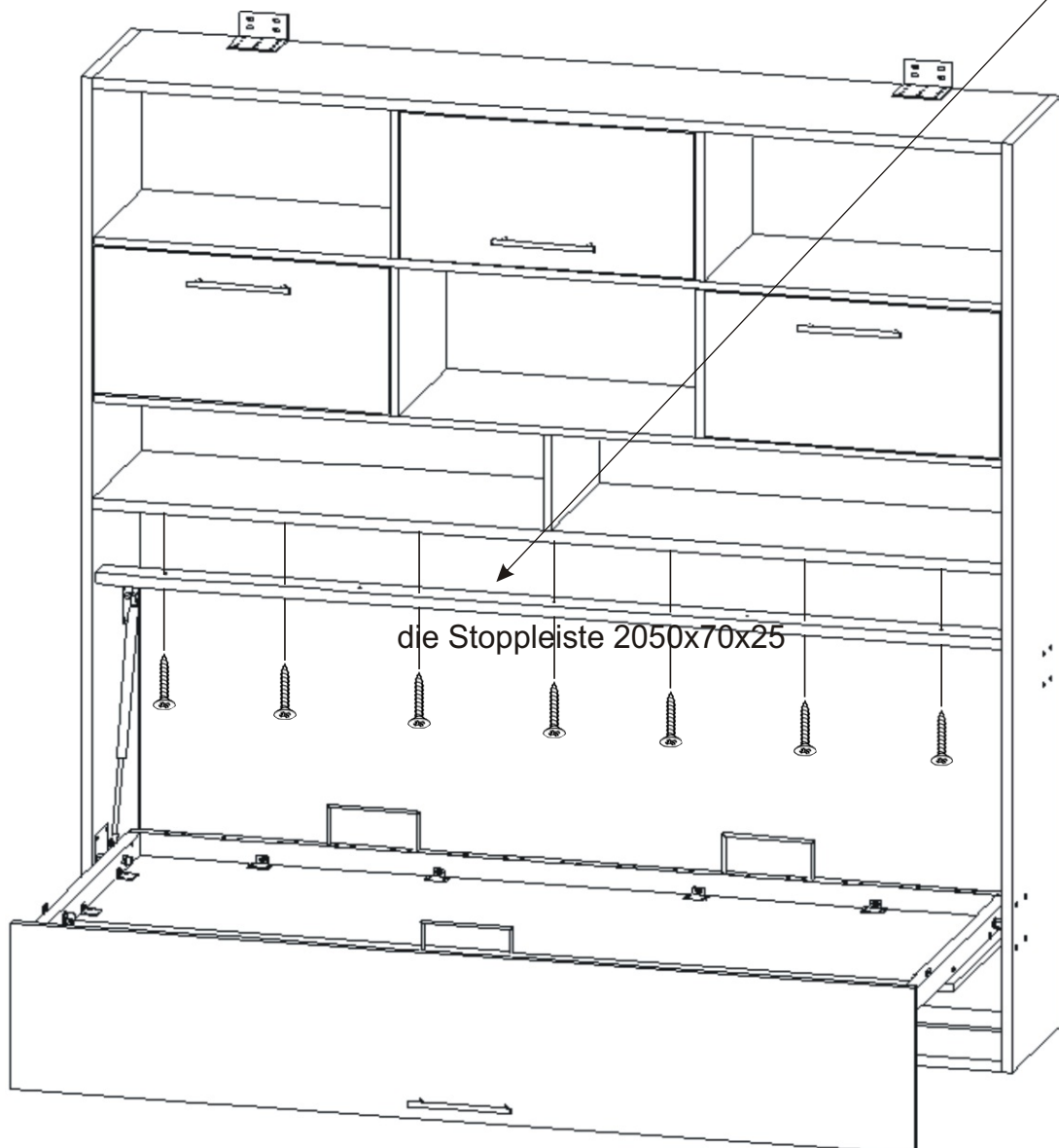
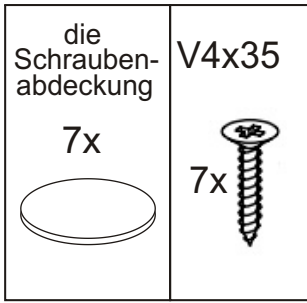
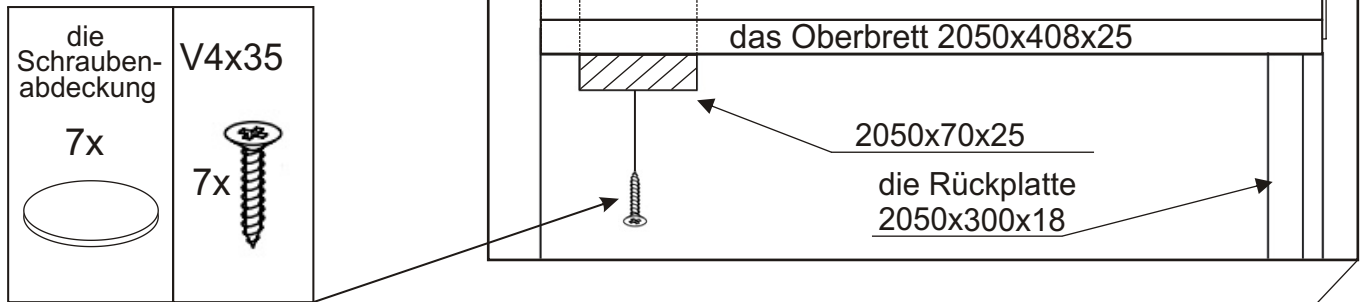

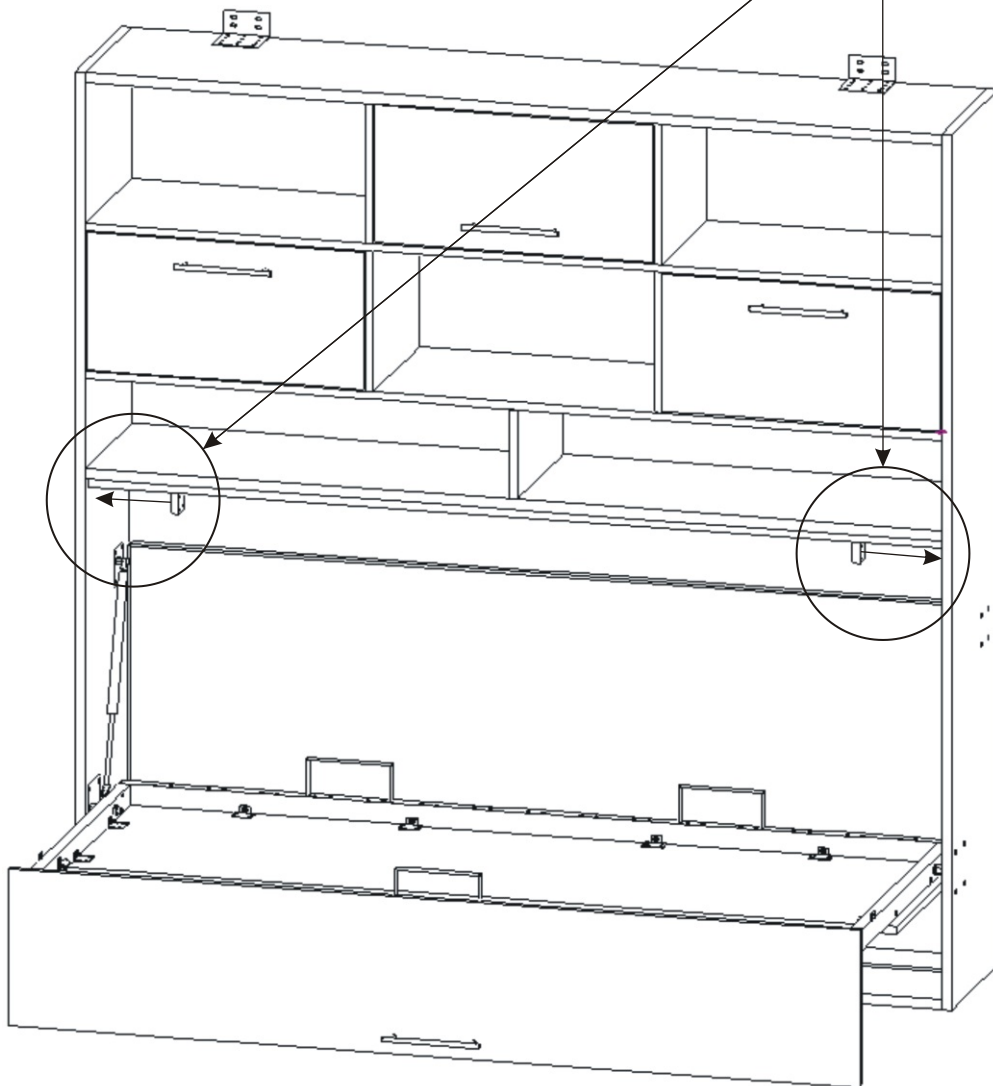
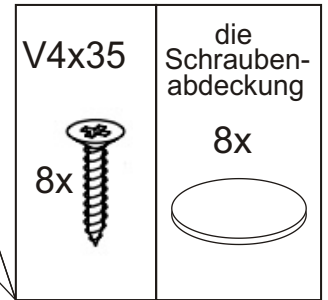
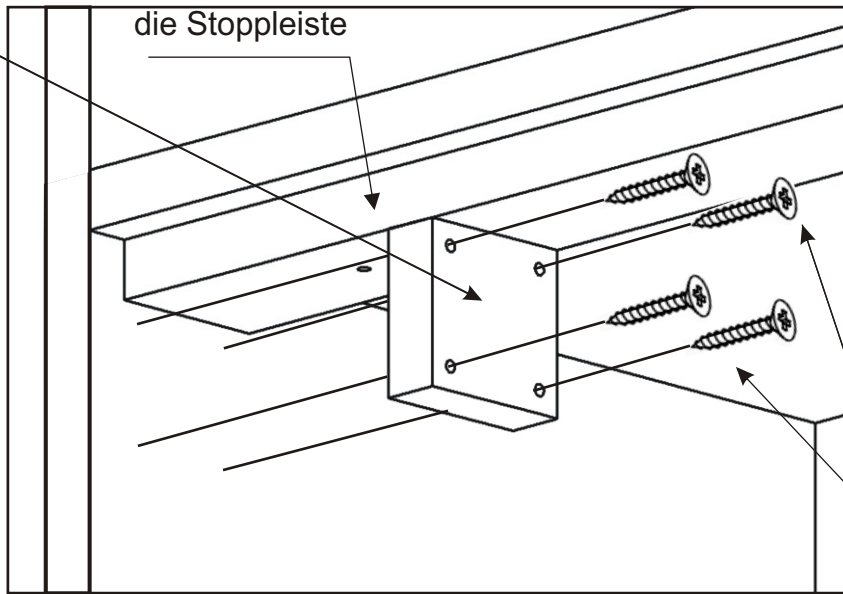
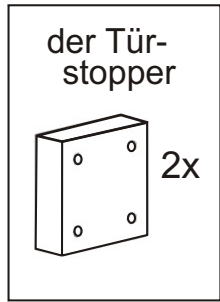

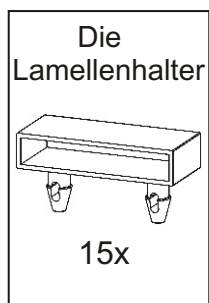
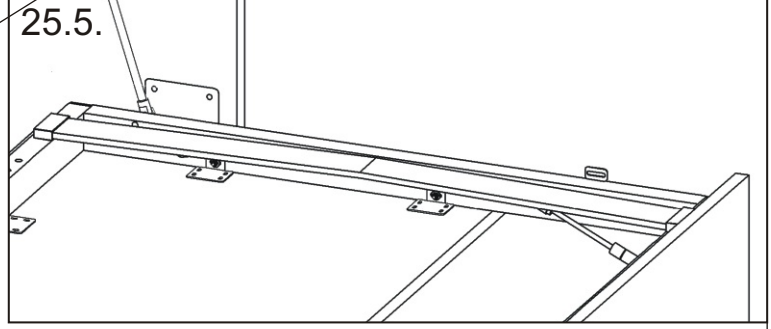
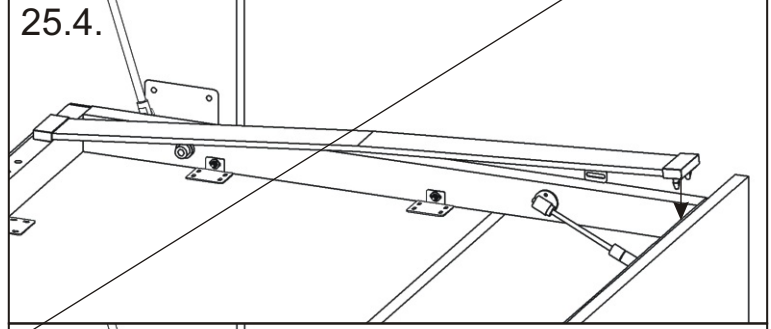
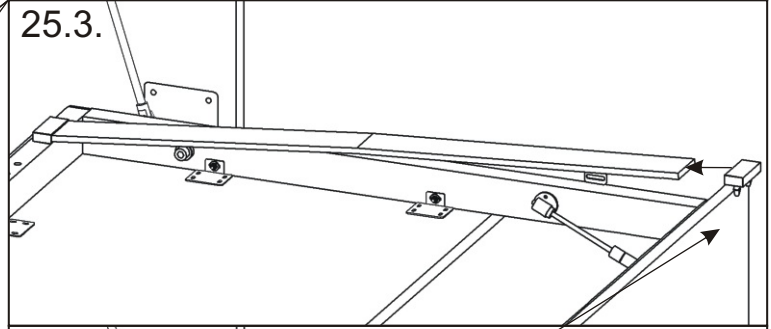
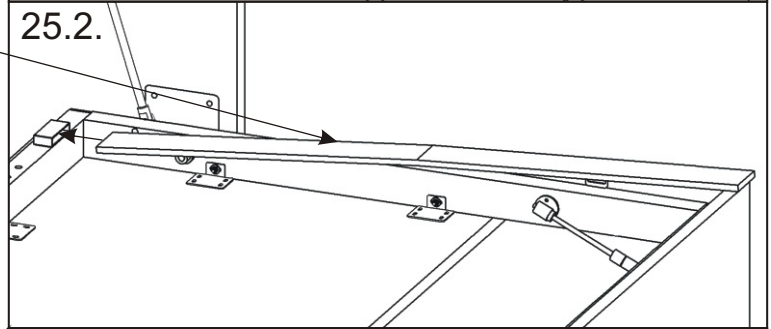
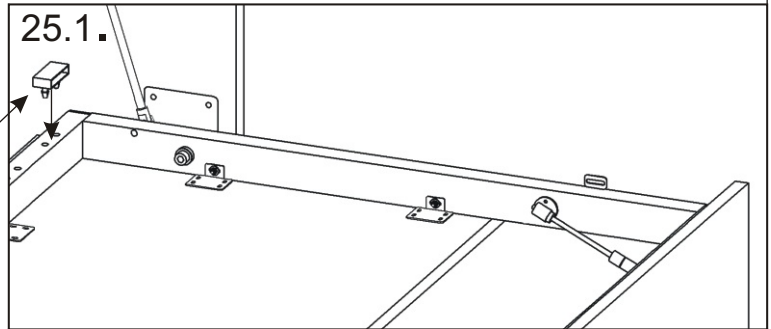
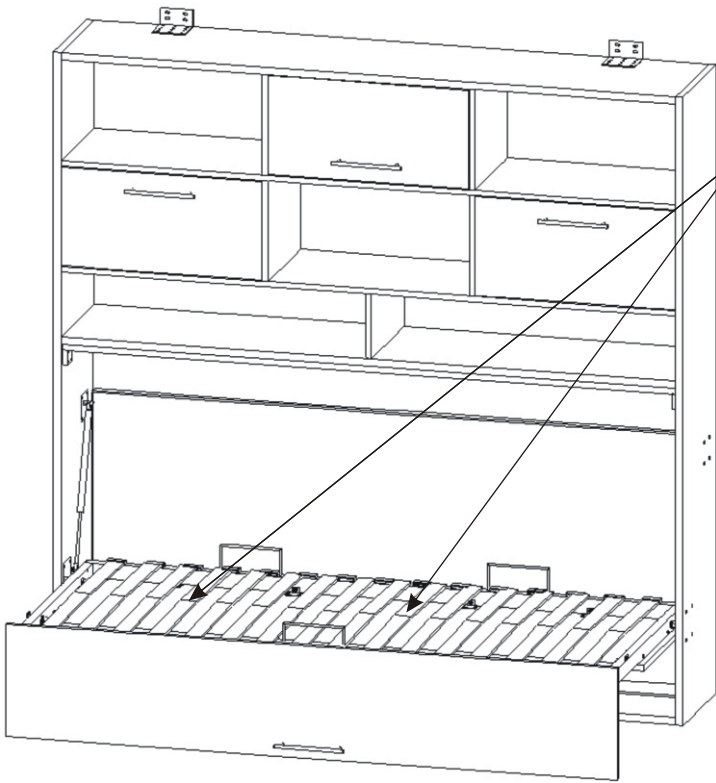
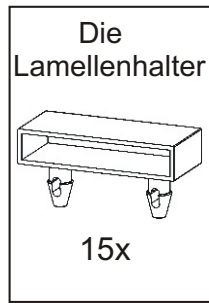
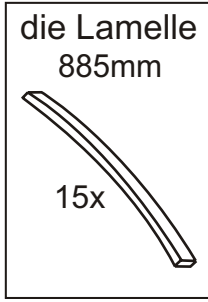

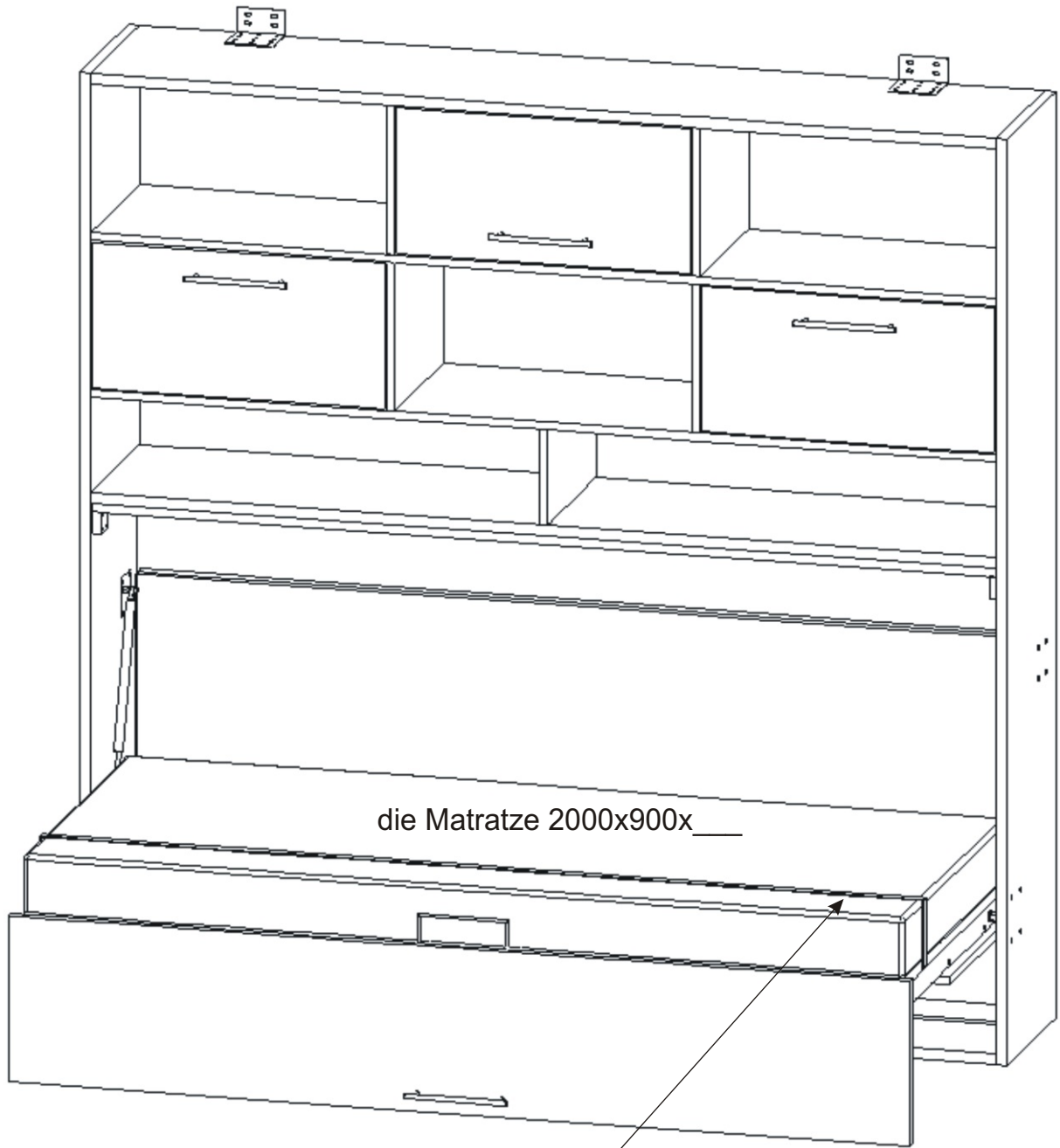

die Matratze 2000x900x___

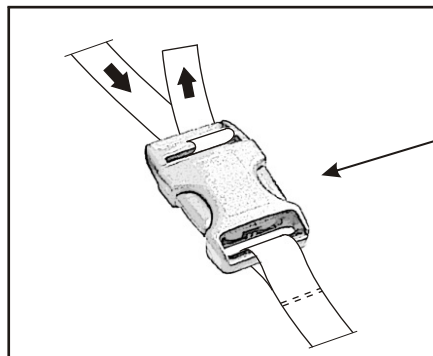

der Gurt

1x

