

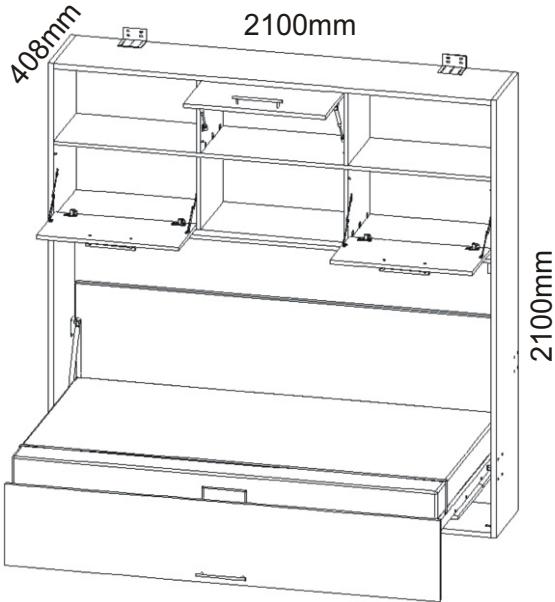











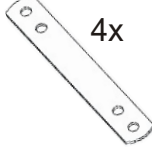
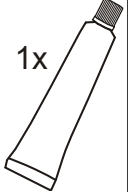

VS 1056P 120 MAX

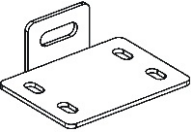
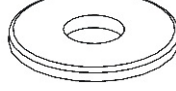
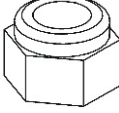
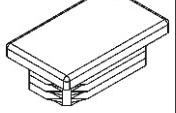
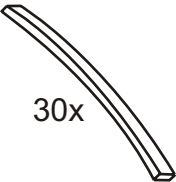
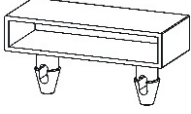

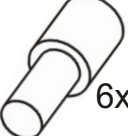
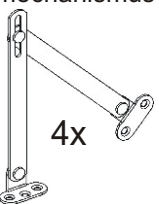

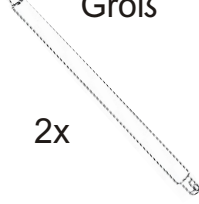
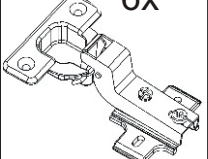



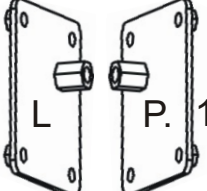
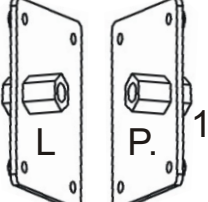
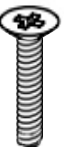
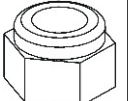

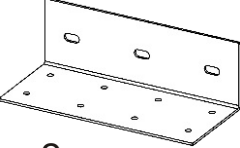
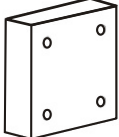

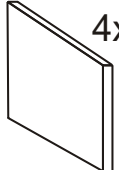
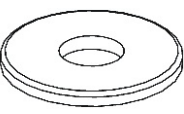

die Schraubenabdeckung 4x 	die Schraubenabdeckung 31x 	V4x30 4x 	Aufhängevorrichtungen 82x12 4x 	Metallkleber 1x 
---	---	--	--	---

Die Euroschraube 12x 	die Zierschraube 4x60 4x 	die Zierschraube 4x40 12x 	der Senkschraube 4x60 12x 	der Türhalter 50x40x20mm 20x 	die Unterlage M4 28x 	die Mutter M4 28x 	der Deckel 50x30 4x 
---	--	---	--	--	---	---	---

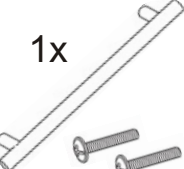
die Lamelle 585mm 30x 	Die Lamellenhalter 60x 	der Nagel 90x 	die Stütze 6x 	der Korbaufhängungsmechanismus 4x 	der Gaskolben klein 120N - 2x 60N - 2x 	der Gaskolben Groß 2x 	das Türband 6x 
--	--	--	---	---	--	---	--

der Verbindungsmechanismus Groß 24x 	der Verbindungsmechanismus klein 40x 	das Absetzblech 80x90 1x L 1x P. 	das Absetzblech 100x120 1x L 1x P. 	M 6x25 die Senkschraube 16x 	die Mutter M8 2x 
--	--	--	---	---	--

der Winkel 150x85x45 2x 	der Türstopper 2x 	der Gurt 1x 	MDF 3mm 4x 	die Unterlage M13 4x 	V4x16 28x 	V3,5x16 42x 	V4x35 15x 
--	---	---	--	---	---	---	---

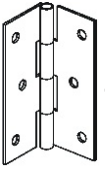
der Halter 192mm 1x 	der Dübel Ø12 6x 	M8x25 2x 	M12x70 2x 	V4x17 84x 	V4x20 16x 	V6x70 6x 	das Türband 60mm 4x 
--	--	--	---	---	---	--	---

1.

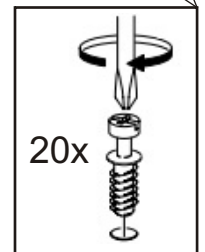
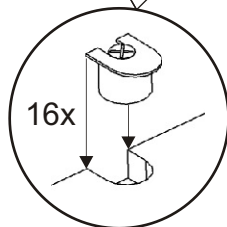
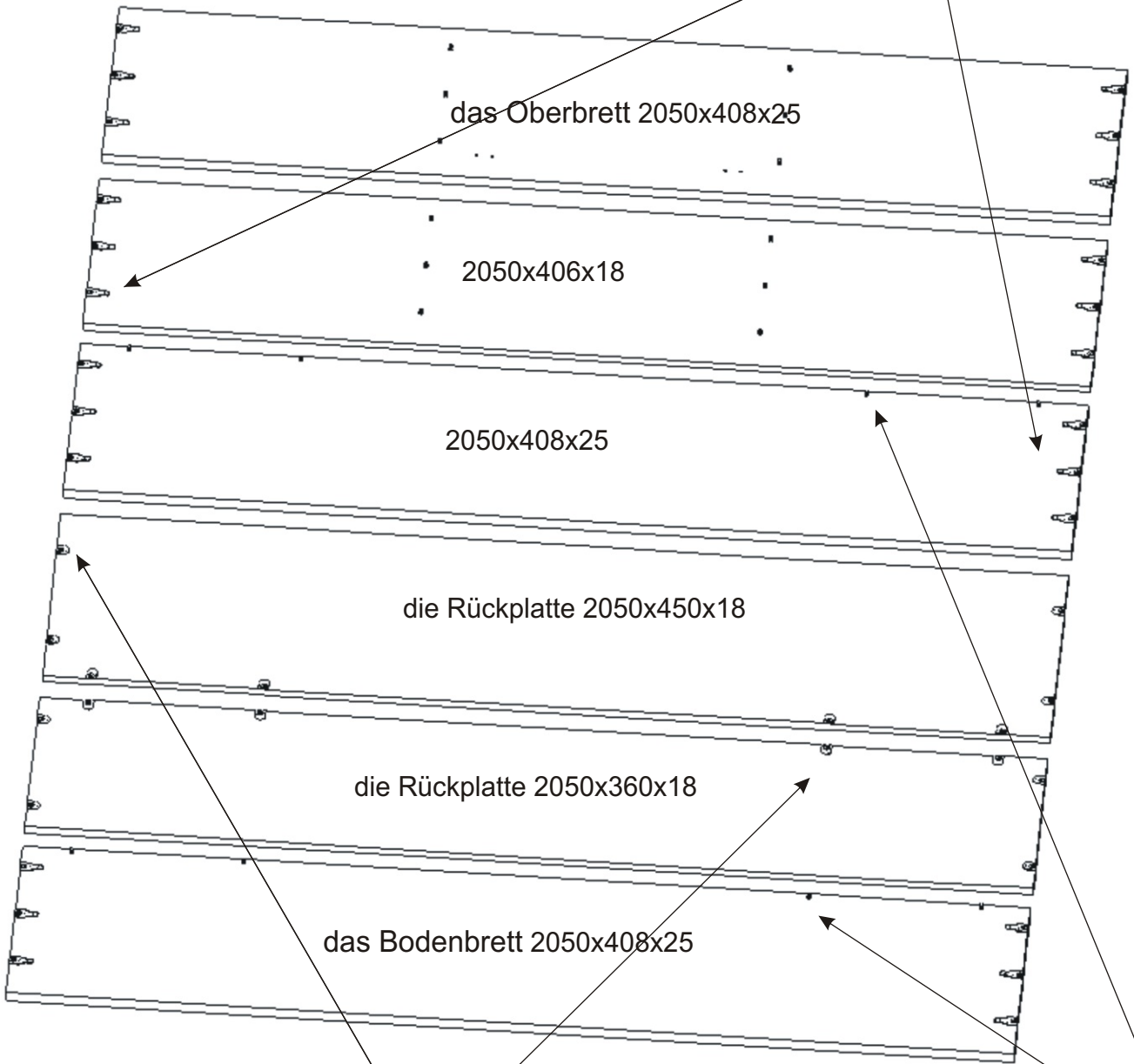
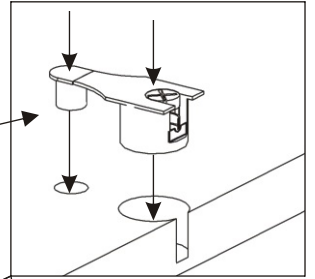
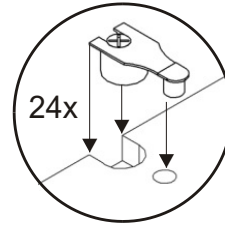

2.

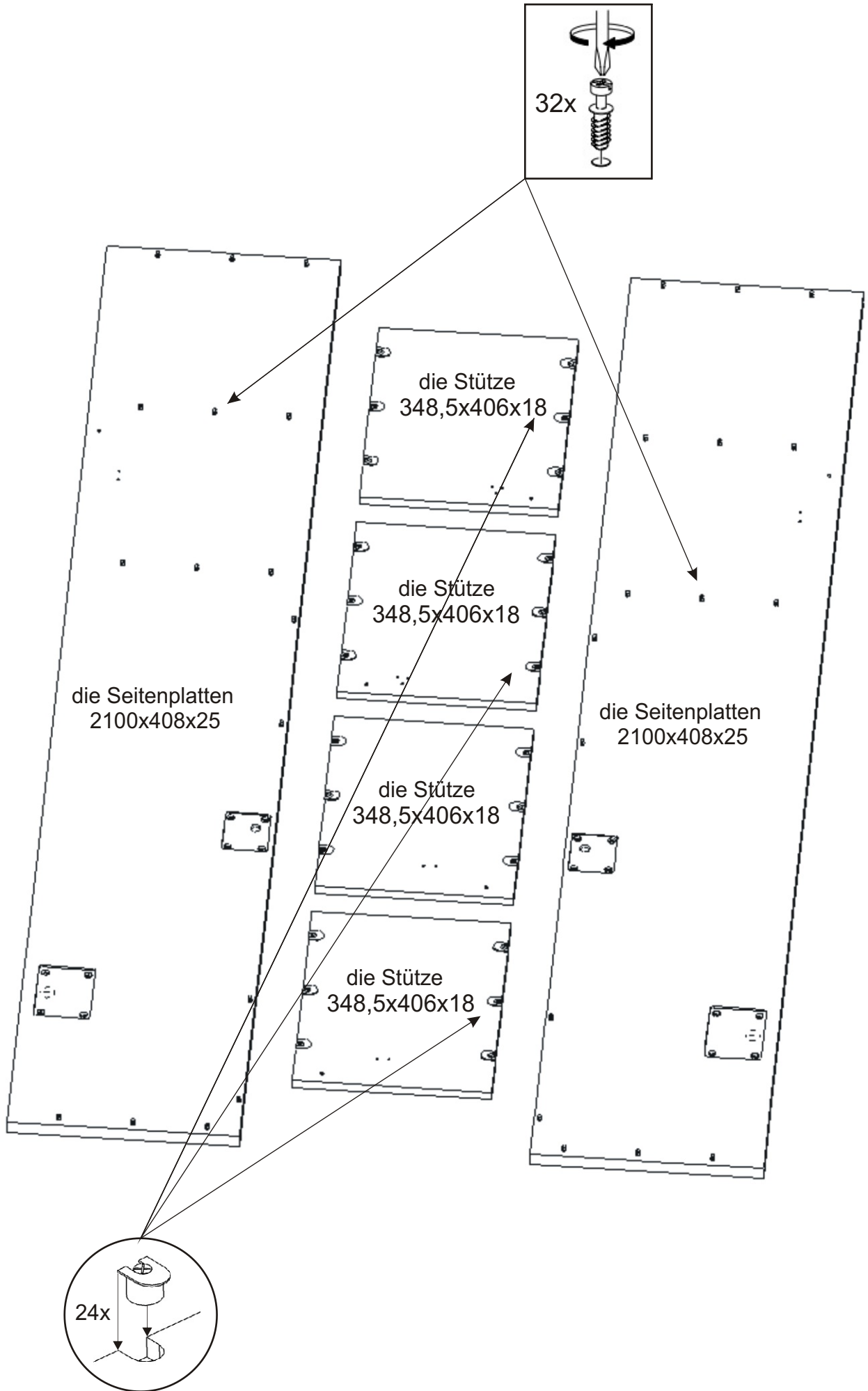

3.

der Halter
192mm

3x



die Tür 666x342x18

die Tür 666x342x18

die Tür 666x342x18

V4x16

12x



V3,5x16

4x

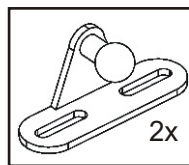
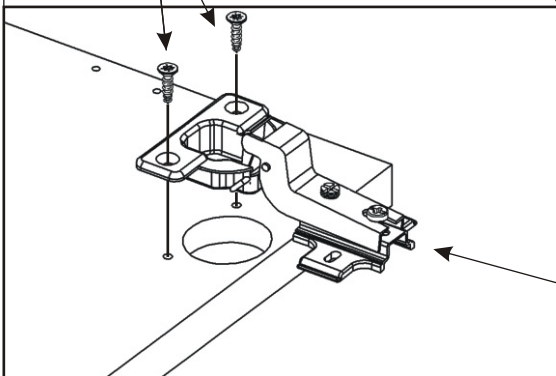

2x

das Türband

6x

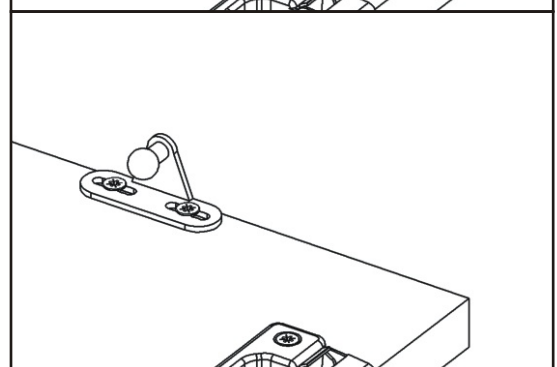
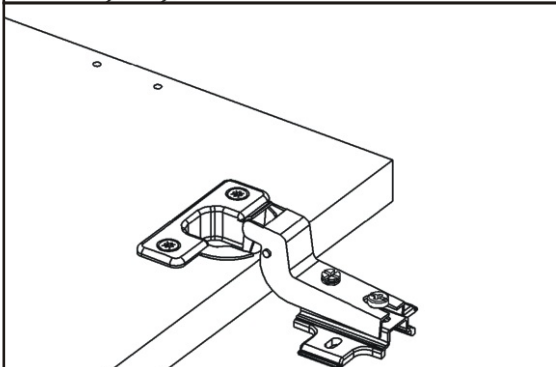
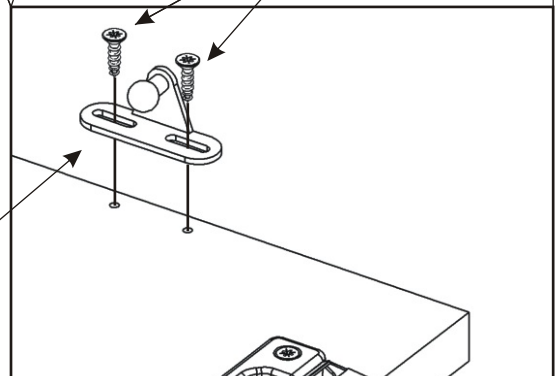
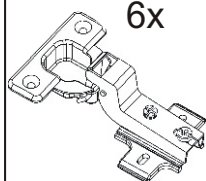

4.

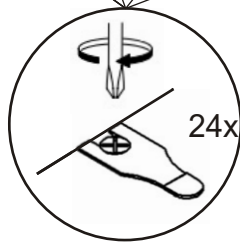
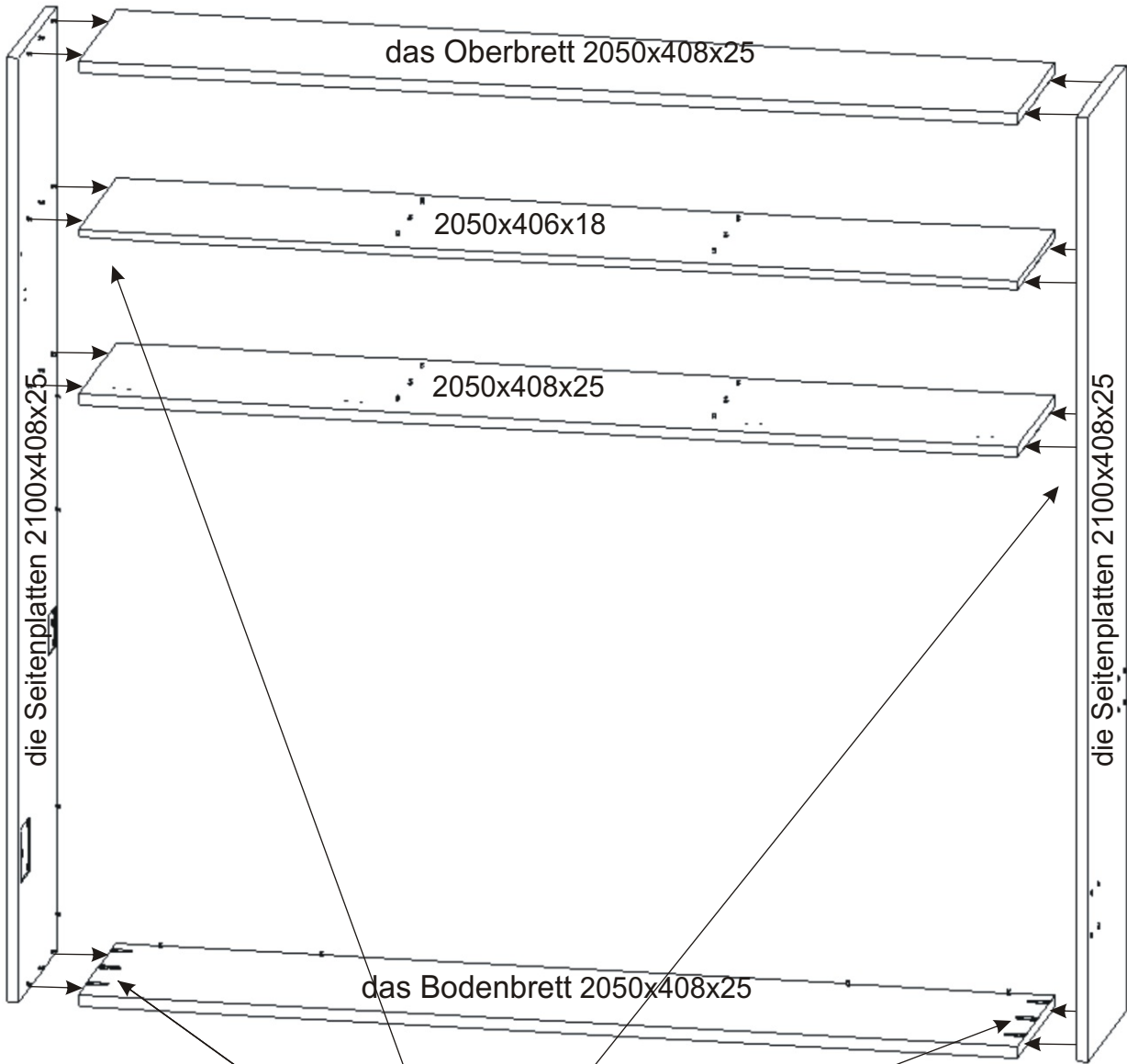

5.

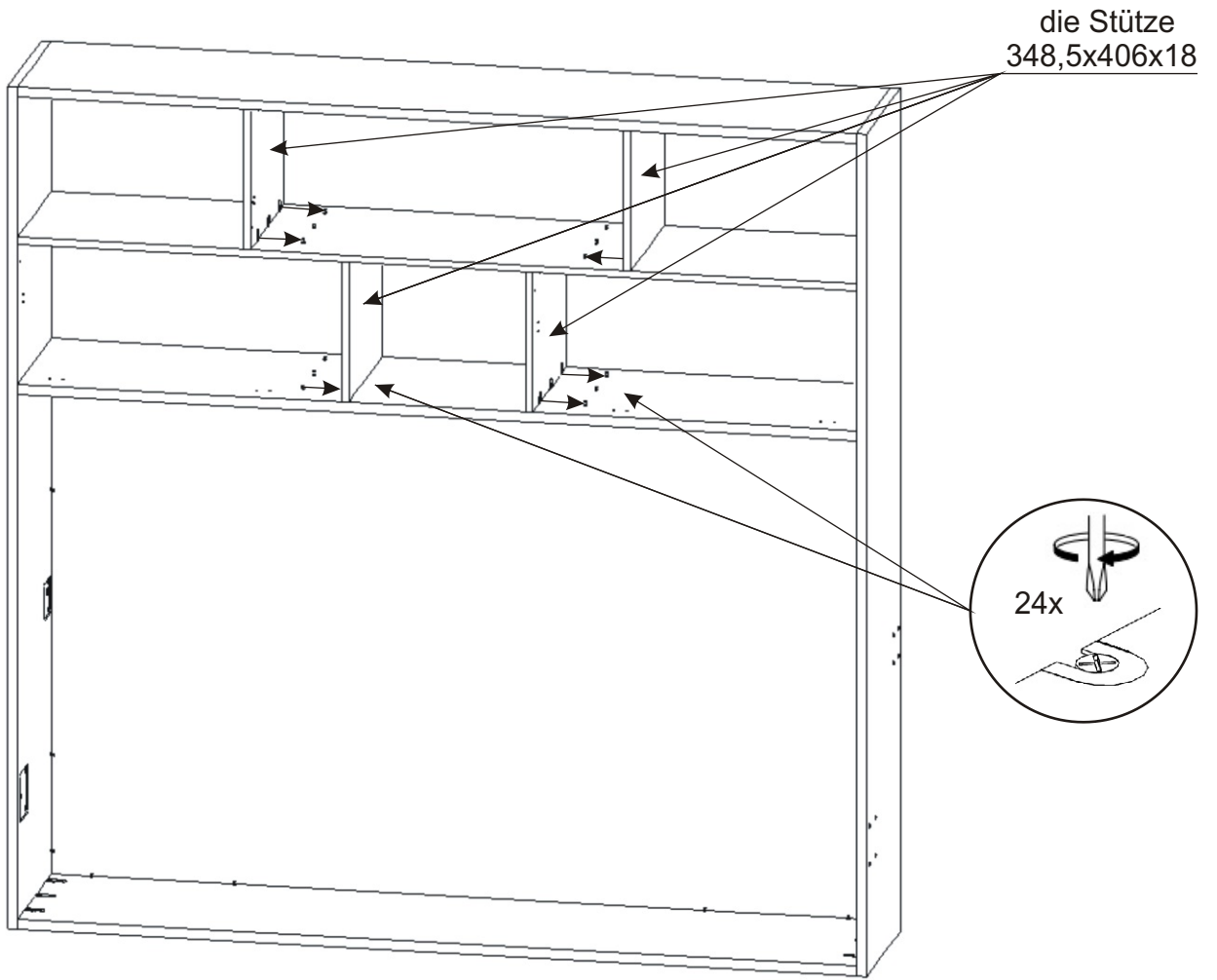

6.

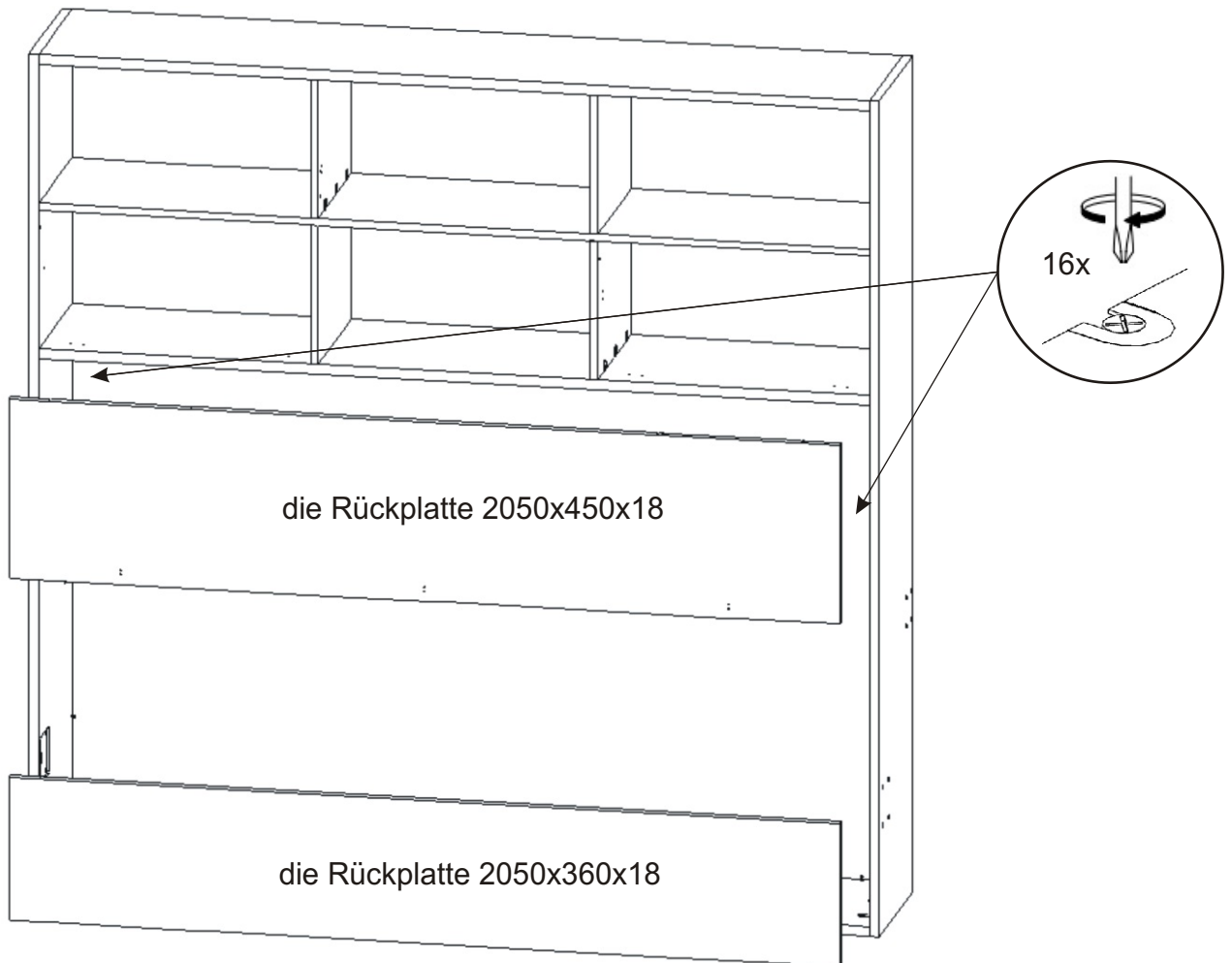

7.

Messen und richten Sie die Diagonalen aus, bevor Sie die Rückseite des Schrankes anbringen.

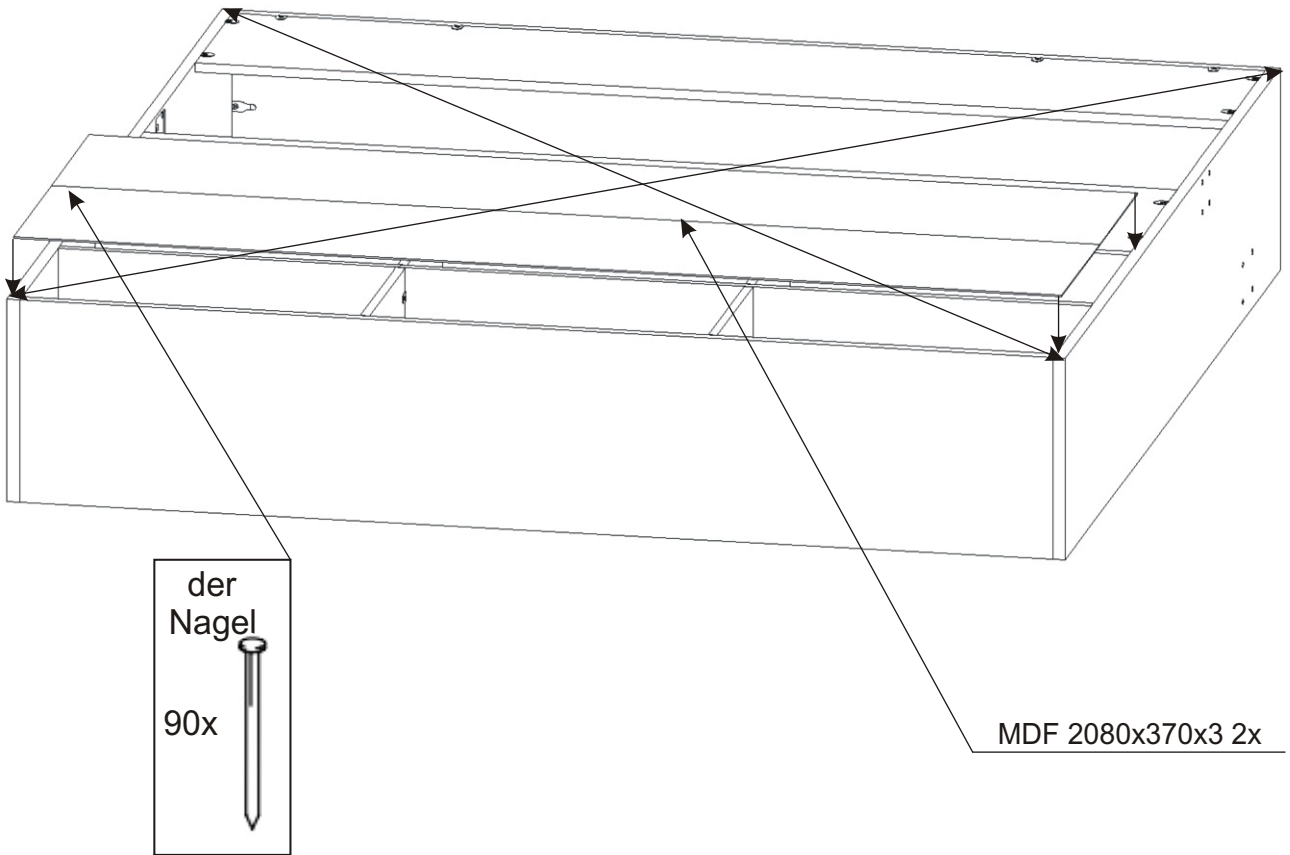

8.

Heben Sie den Körper des Bettes mit einem Kollegen an.

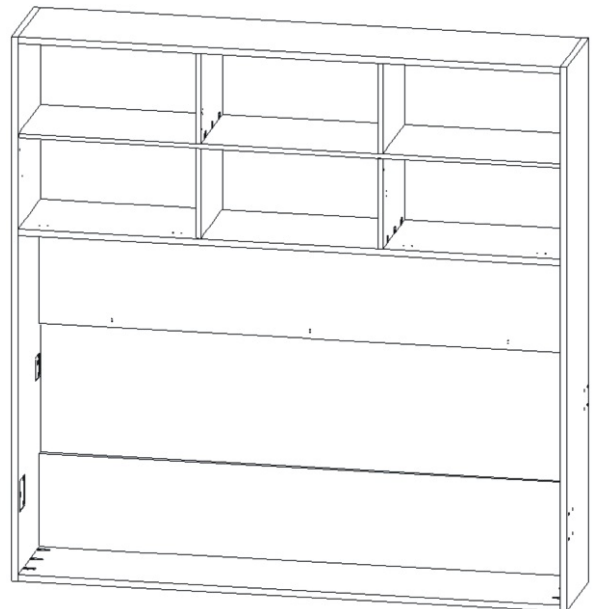
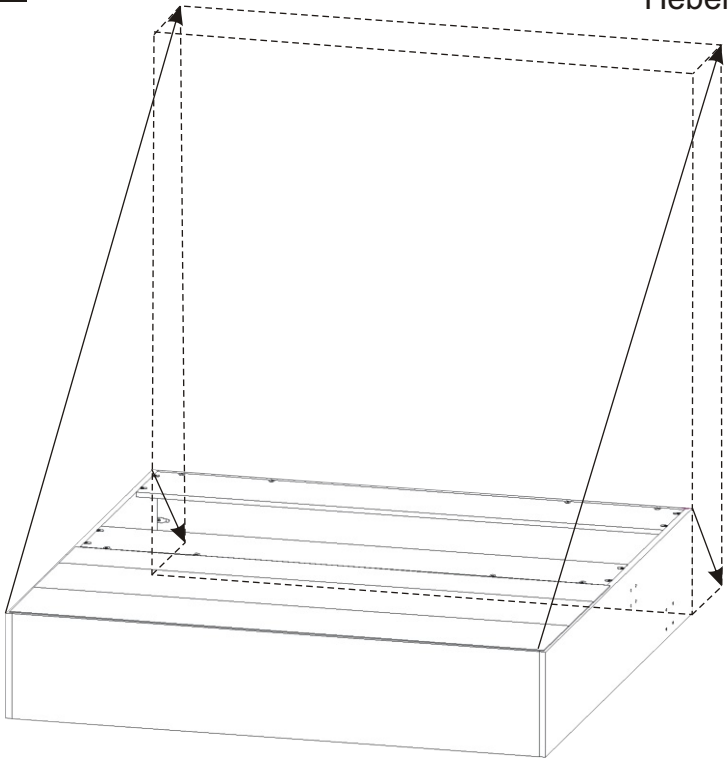

9.

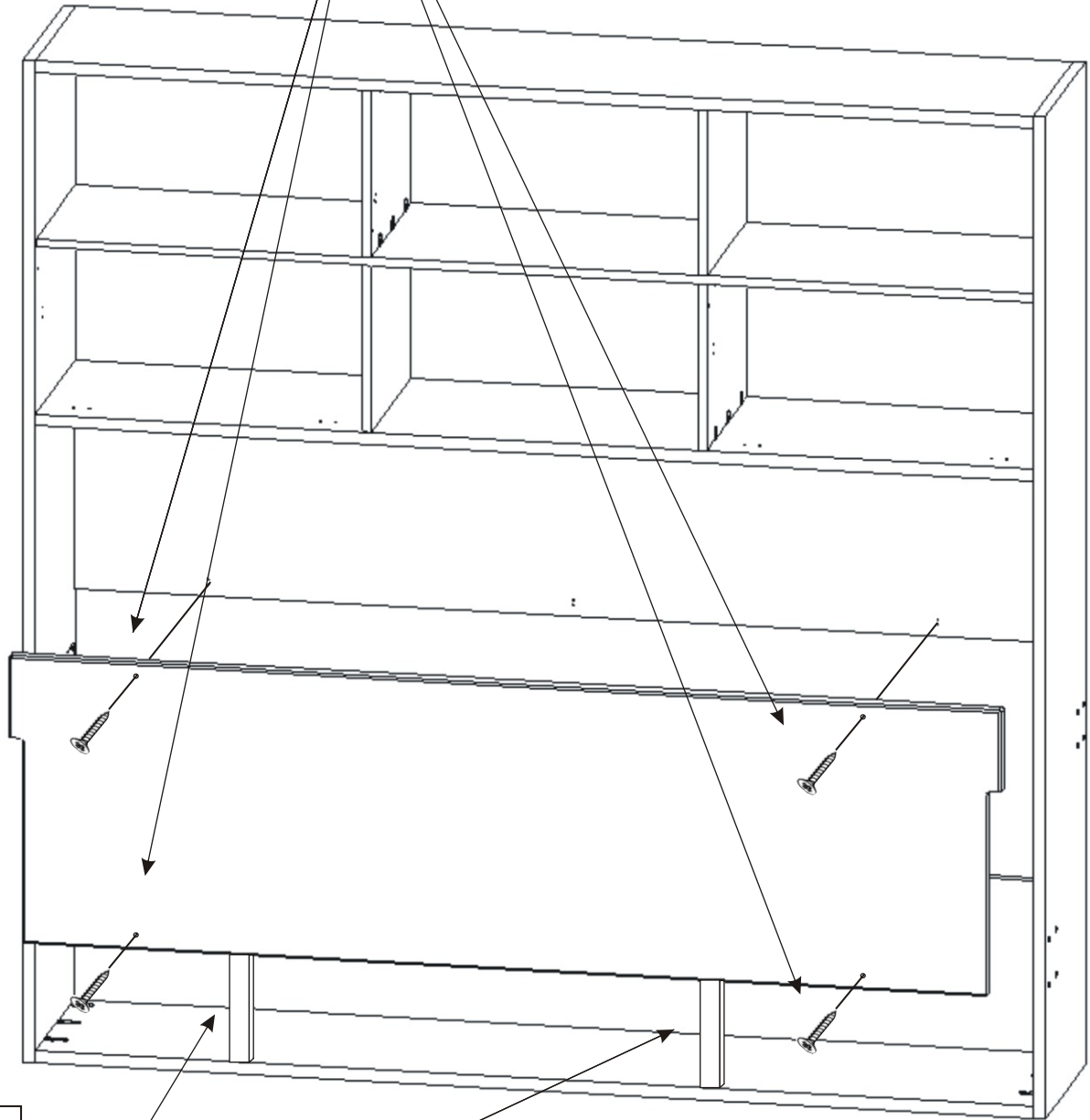
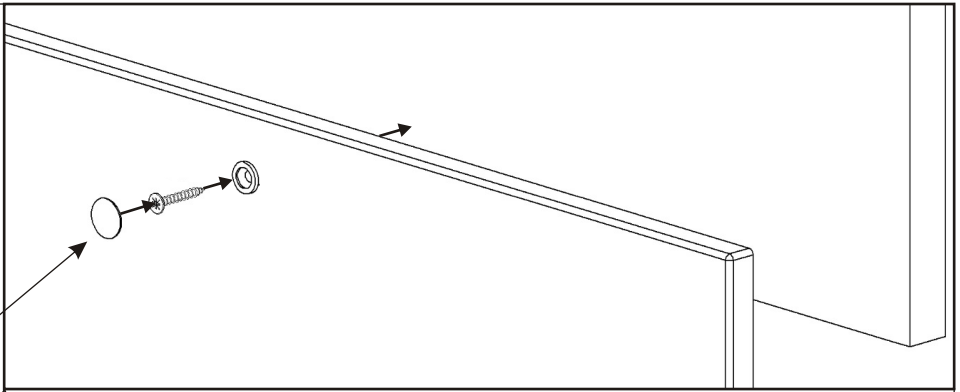
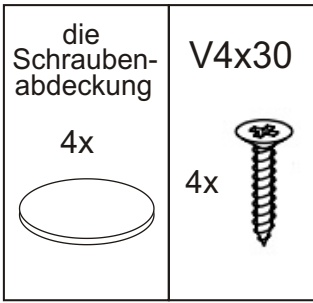

das Hilfsbretter
300x70x18

2x



1. Sitzen Sie das zwei Hilfsbretter ein,
um die Vorderseite zu befestigen.
2. Legen Sie des gepolsterte Vorderteil auf
die Trägerbretter, und ein Kollege
hält den Vorderteil fest.

10.

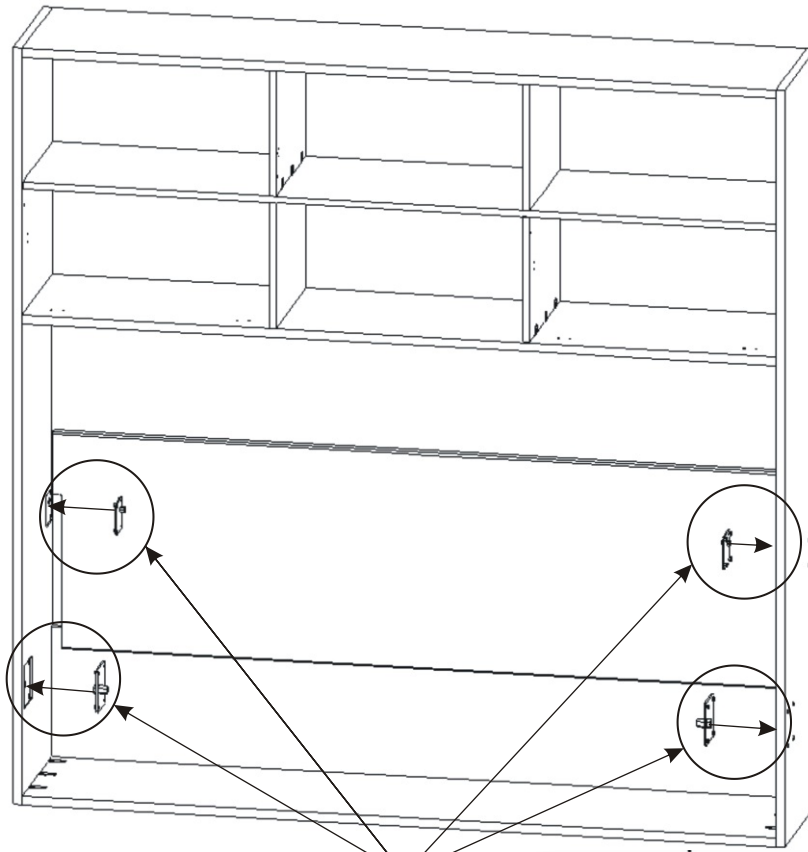

M 6x25
die Senkschraube

16x

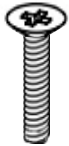

die Schraubenabdeckung

16x



die Seitenplatten
2100x408x25

das Absetzblech
80x90

2x

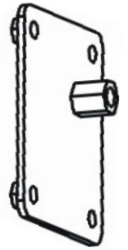

das Absetzblech
100x120

2x

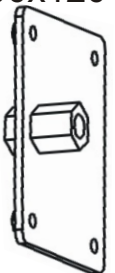

Das Klappbett muss vor der Montage des Metallrosts an der Wand befestigt werden. Andernfalls besteht beim Öffnen Absturz- und Verletzungsgefahr!

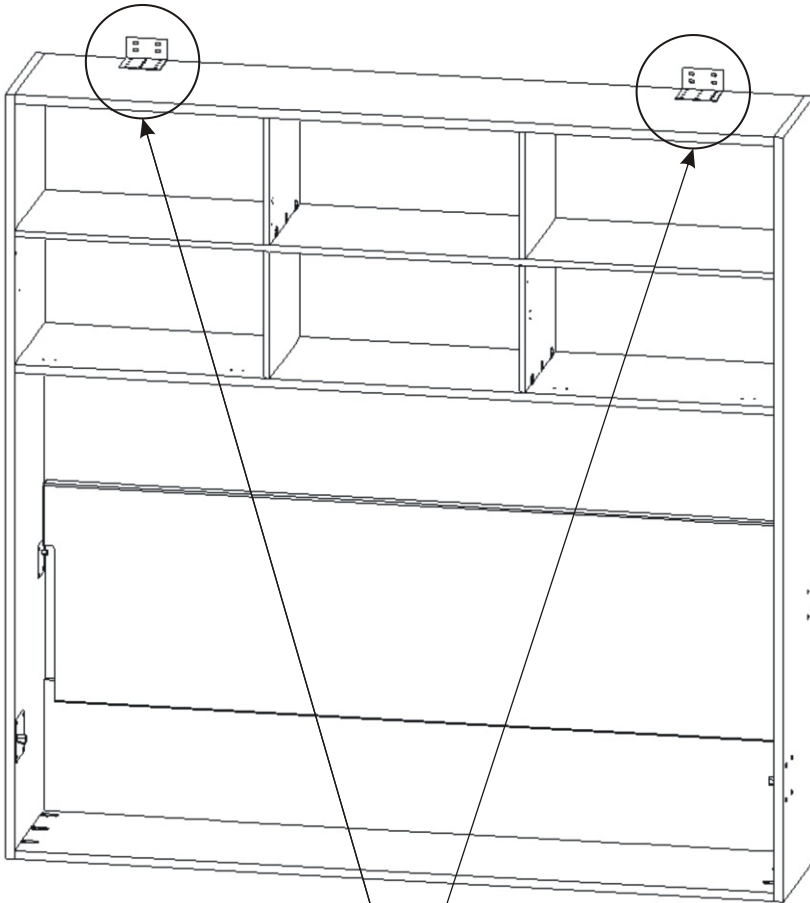

Die Anzahl und die Art der Dübel müssen je nach Wandtyp bestimmt werden.

V4x20

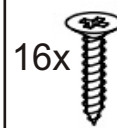

16x

der Dübel
ø12x60

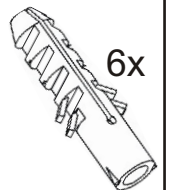

6x

der Winkel
150x85x45

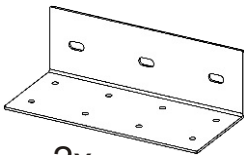

2x

V6x70



6x

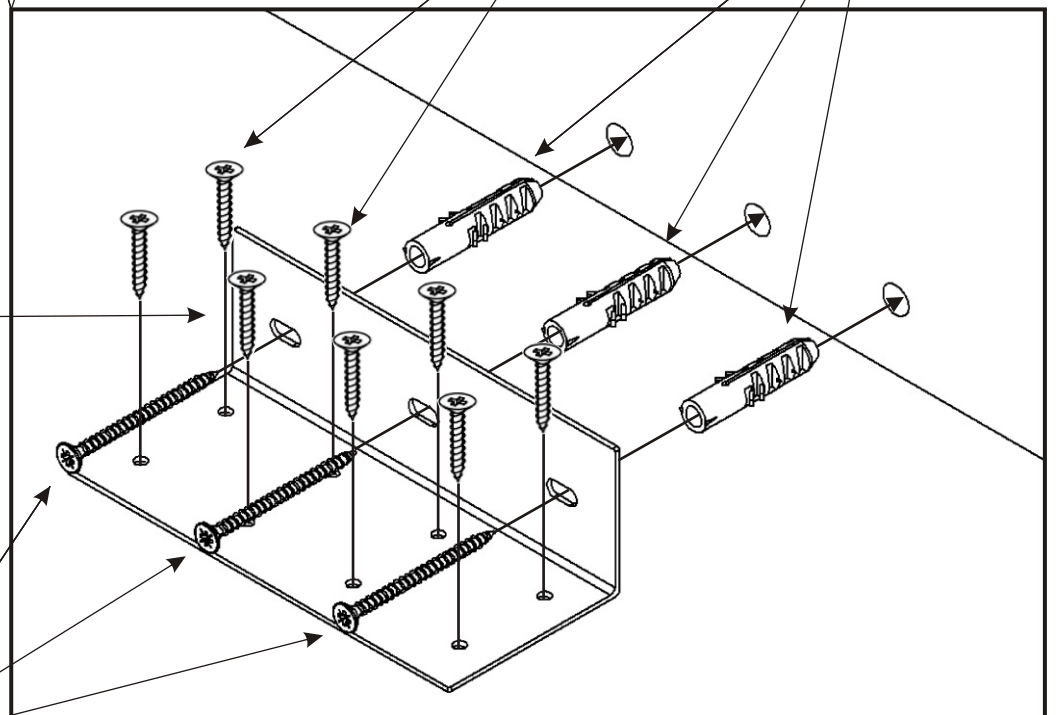

12.

12.1.

die Stütze 348,5x406x18

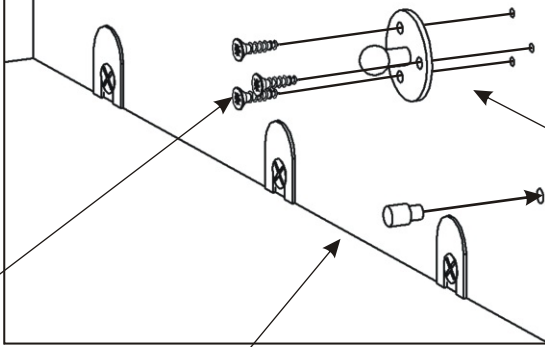

12.2.

die Tür 666x342x18

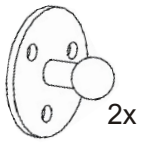
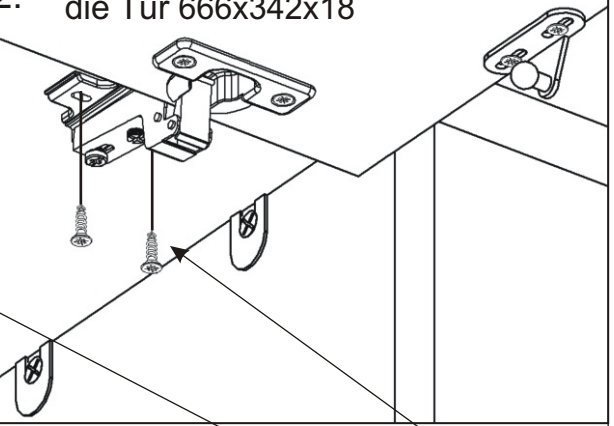

die Stütze

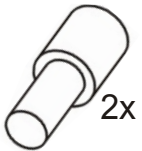

V3,5x16

6x



V4x16

4x

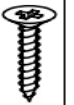

der Gaskolben klein

60N - 2x

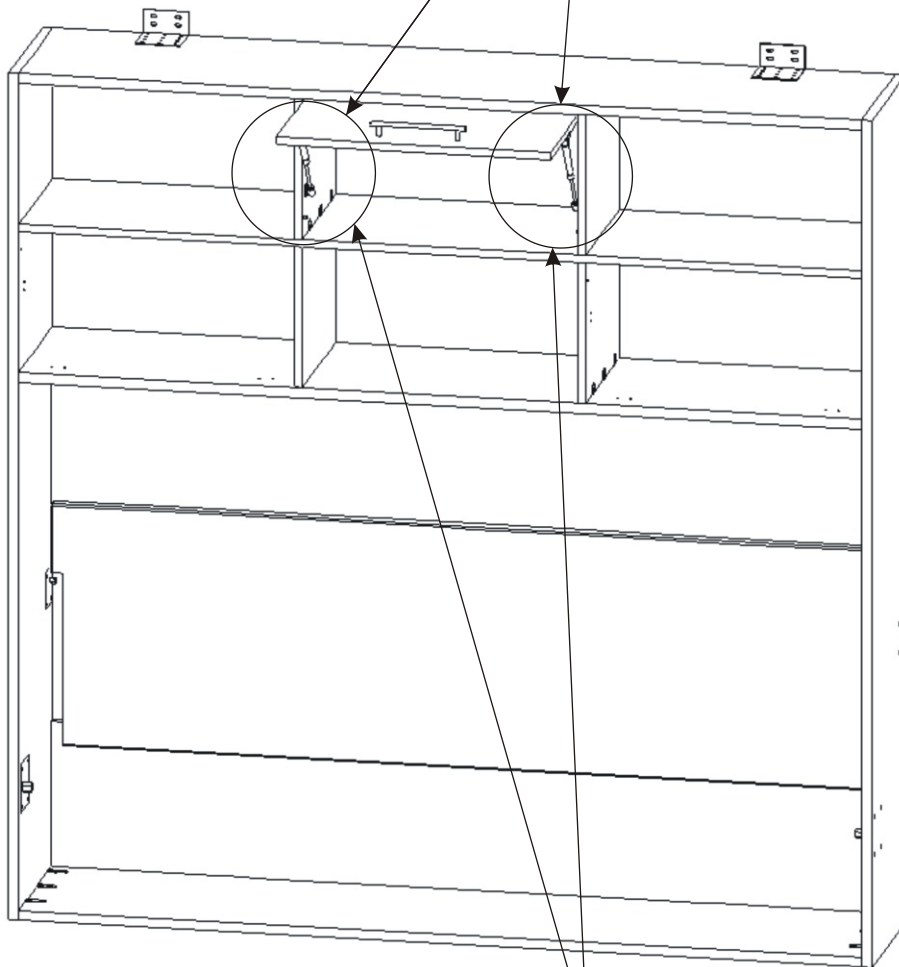

12.3.

das Oberbrett 2050x408x25

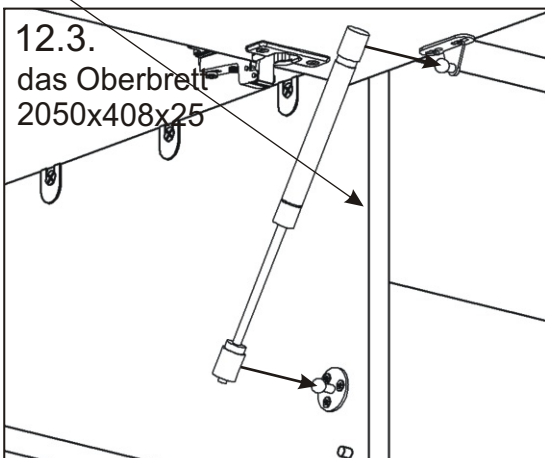

12.4.

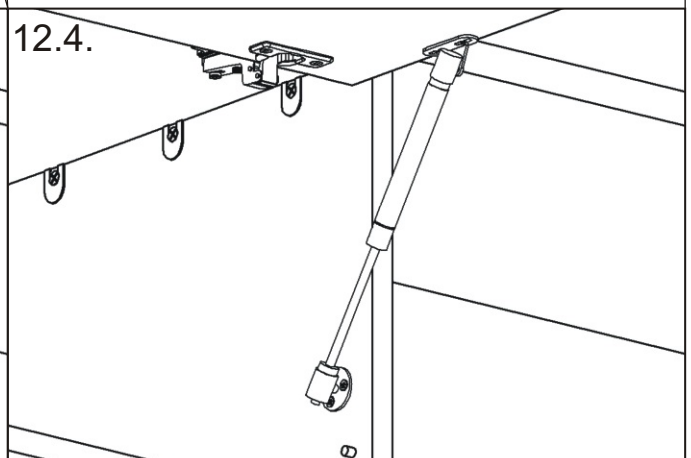

13.1.

2050x406x18

13.2.

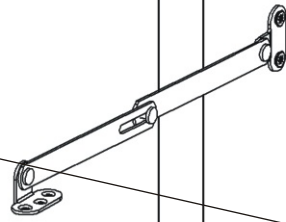
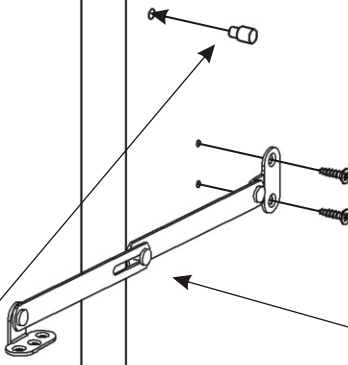

die Stütze

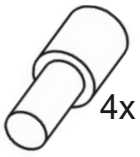

4x

V3,5x16

der Korbaufhängungsmechanismus

8x

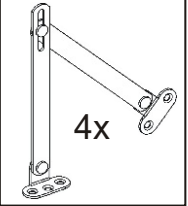

4x

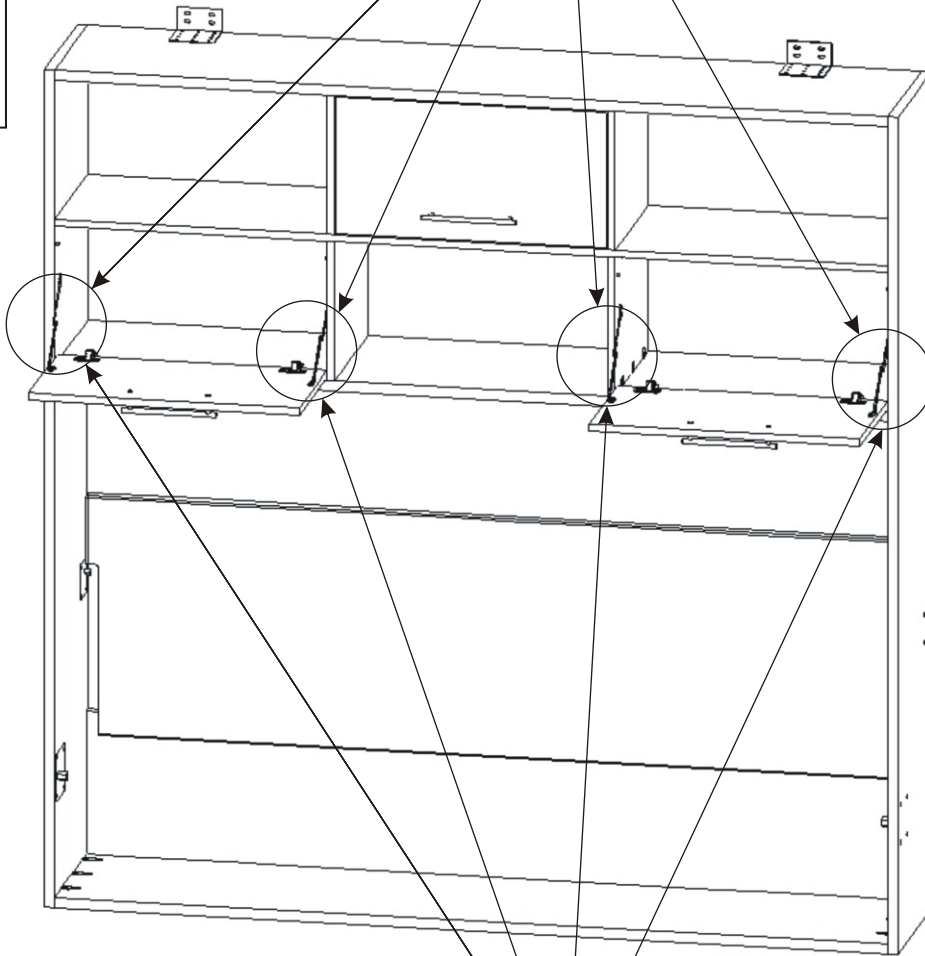

V3,5x16

8x



V4x16

6x



13.3.

13.4.

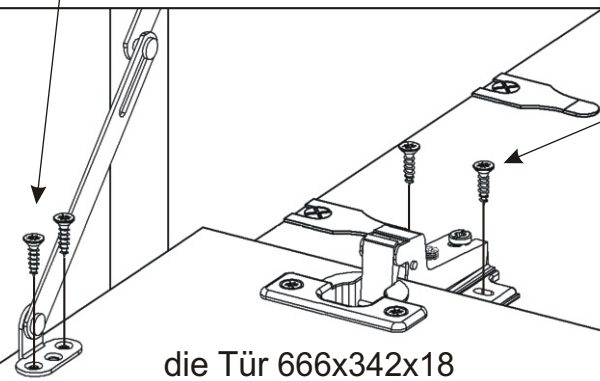

die Tür 666x342x18

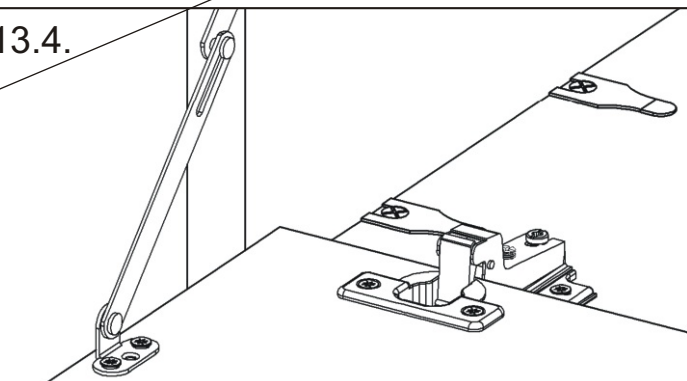

14.

die Unterlage
M4

12x

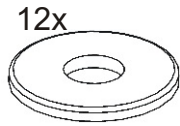

die Mutter
M4

12x

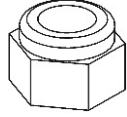

Der Türhalter
50x40x20mm

12x

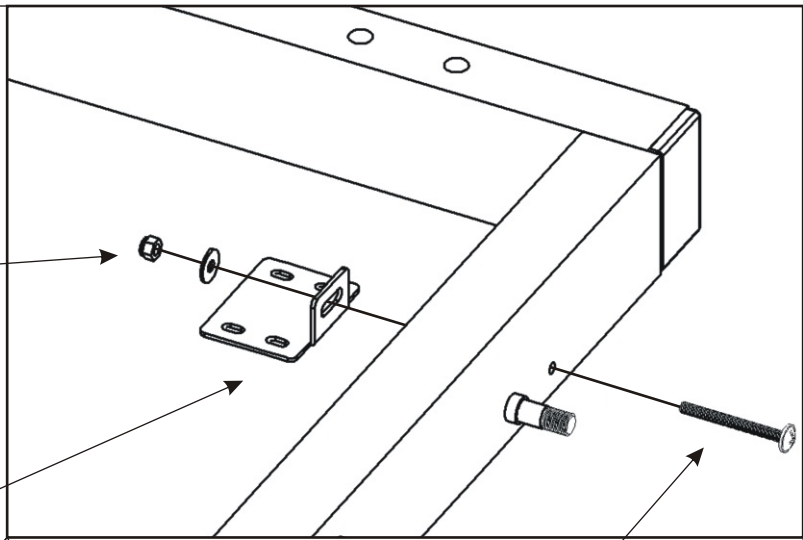
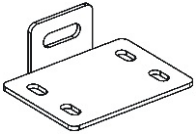

die Zier-
schraube
4x40

12x

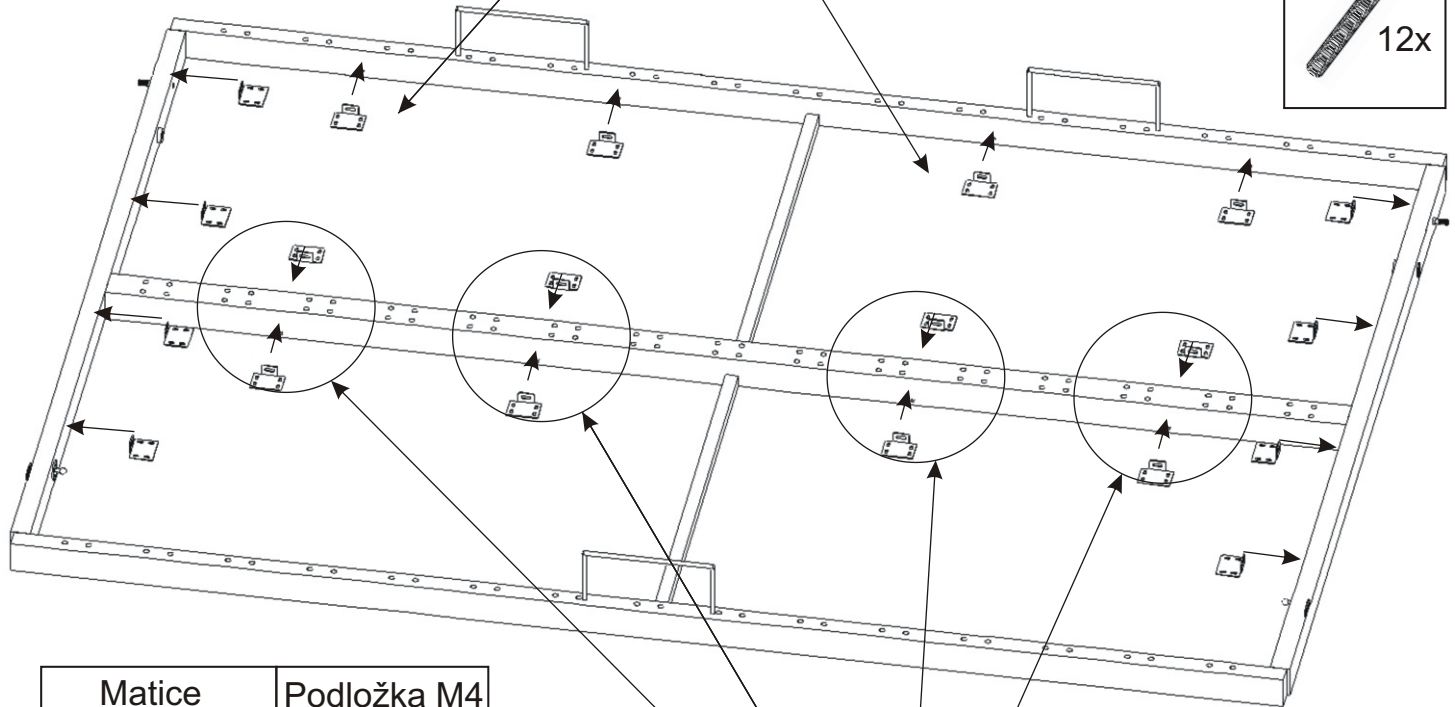

Matices
samojistná M4
4x

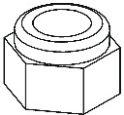

Podložka M4

4x

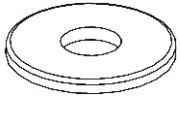

Der Türhalter
50x40x20mm

8x

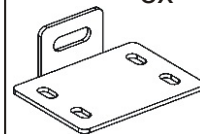

die Zier-
schraube
4x60

4x

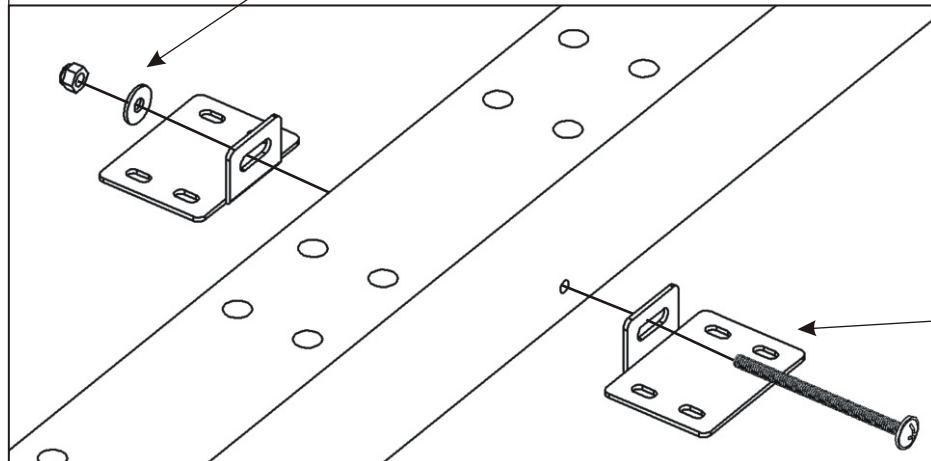

15.

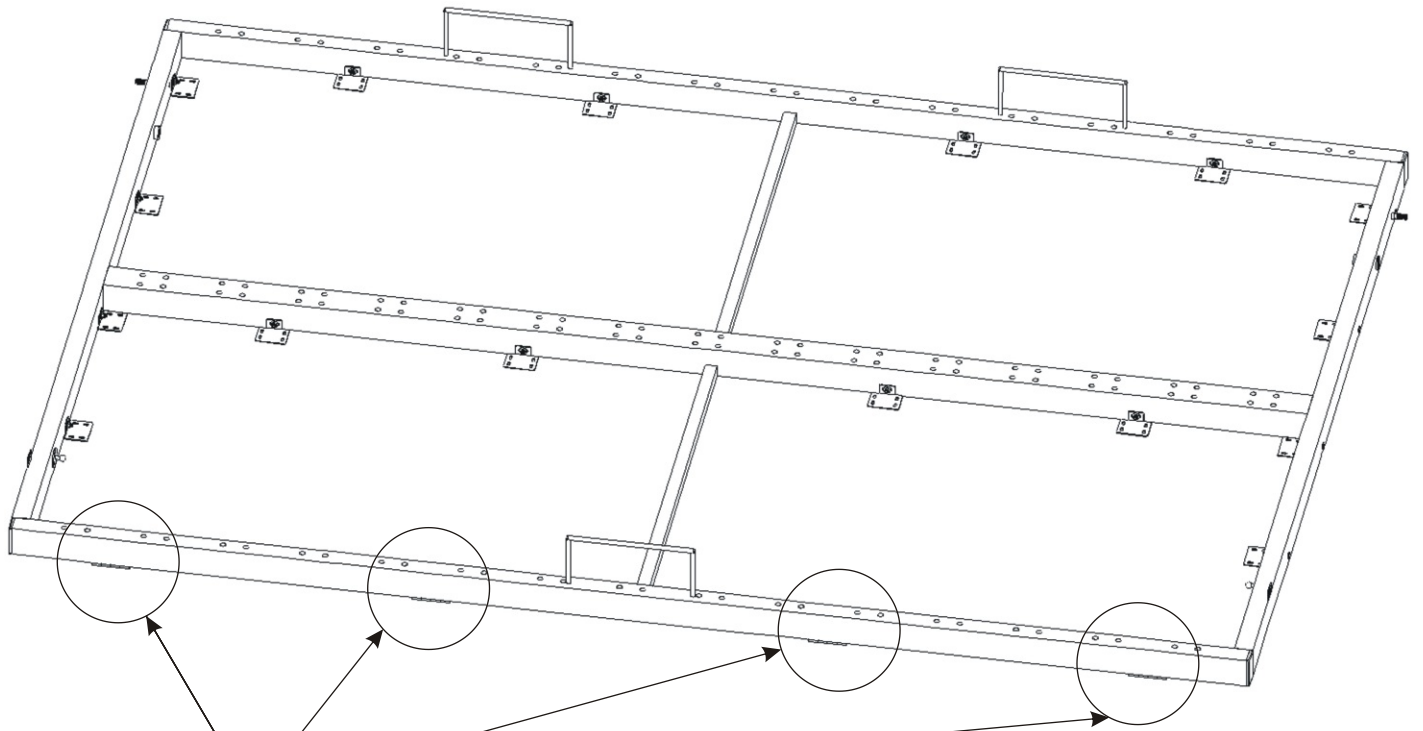

die Mutter
M4
12x

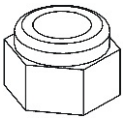

die Unterlage
M4
12x

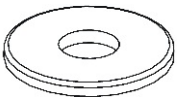

das Türband
60mm

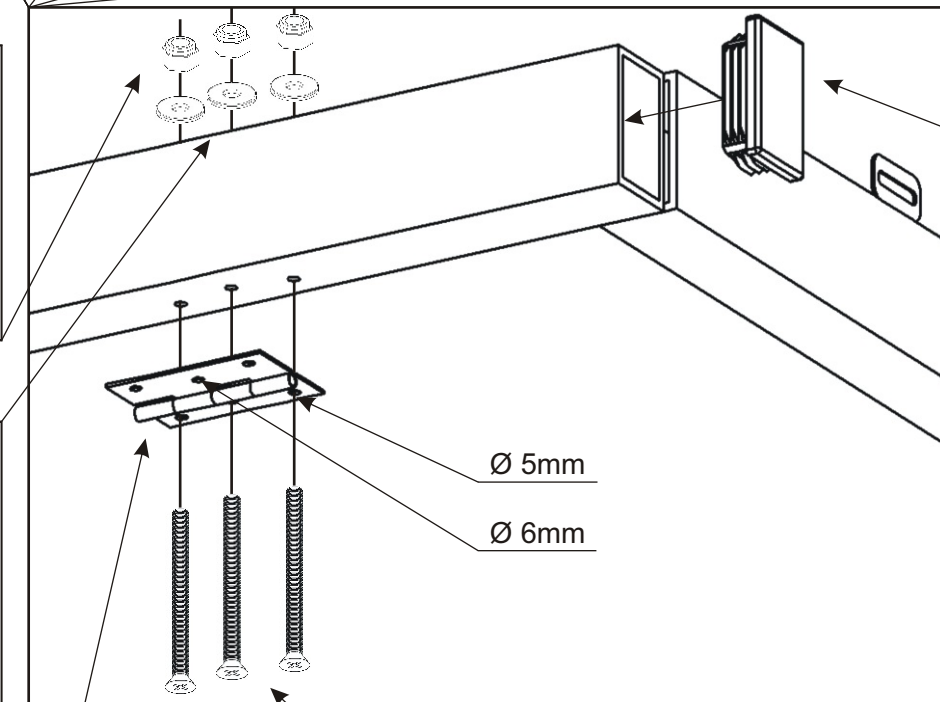
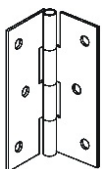

der Deckel
50x30
4x

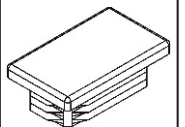

der Senk-
schraube
4x60

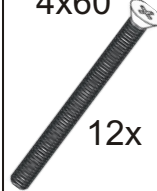

Ø 5mm

Ø 6mm

12x

16.

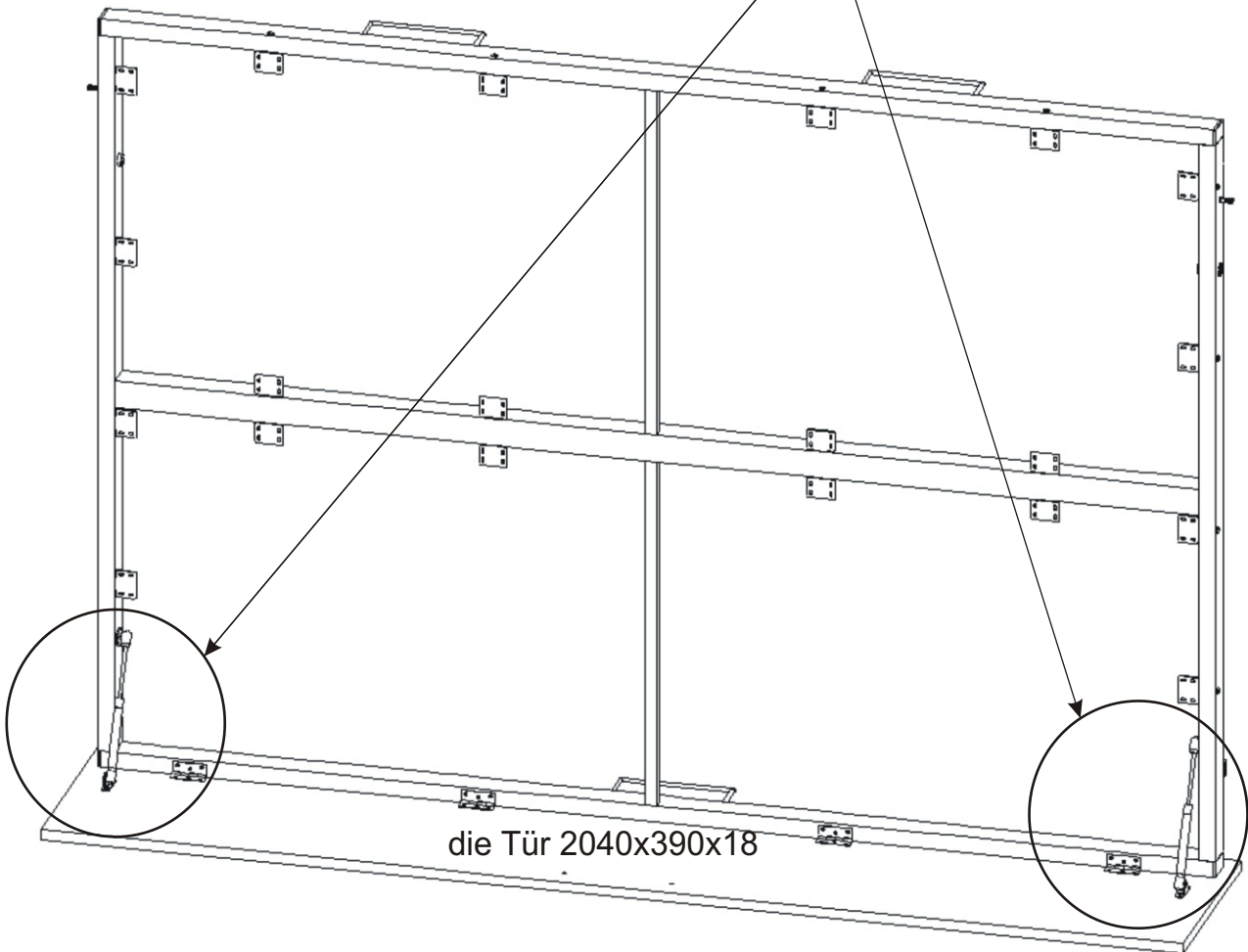
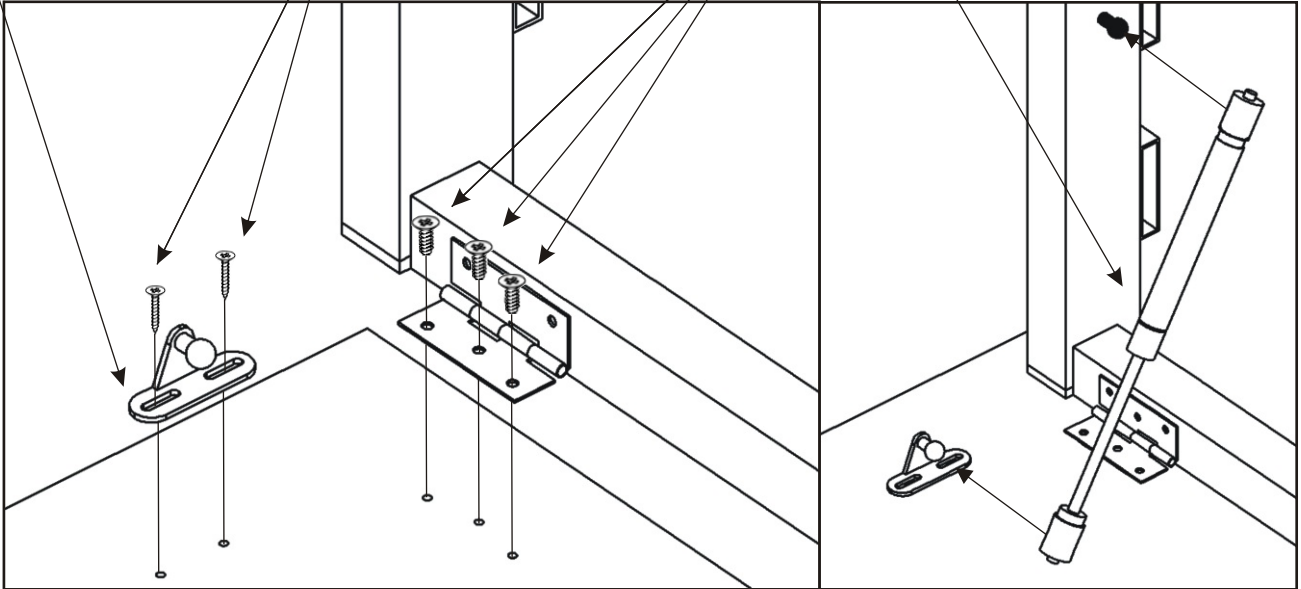
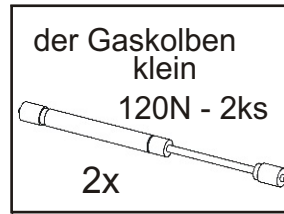
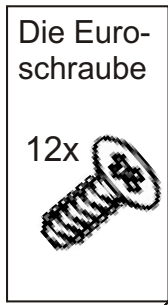
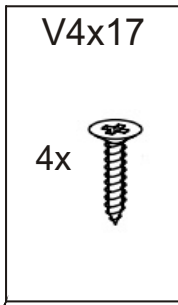
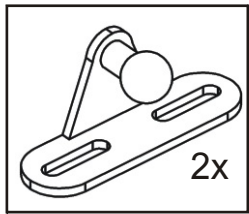

17.

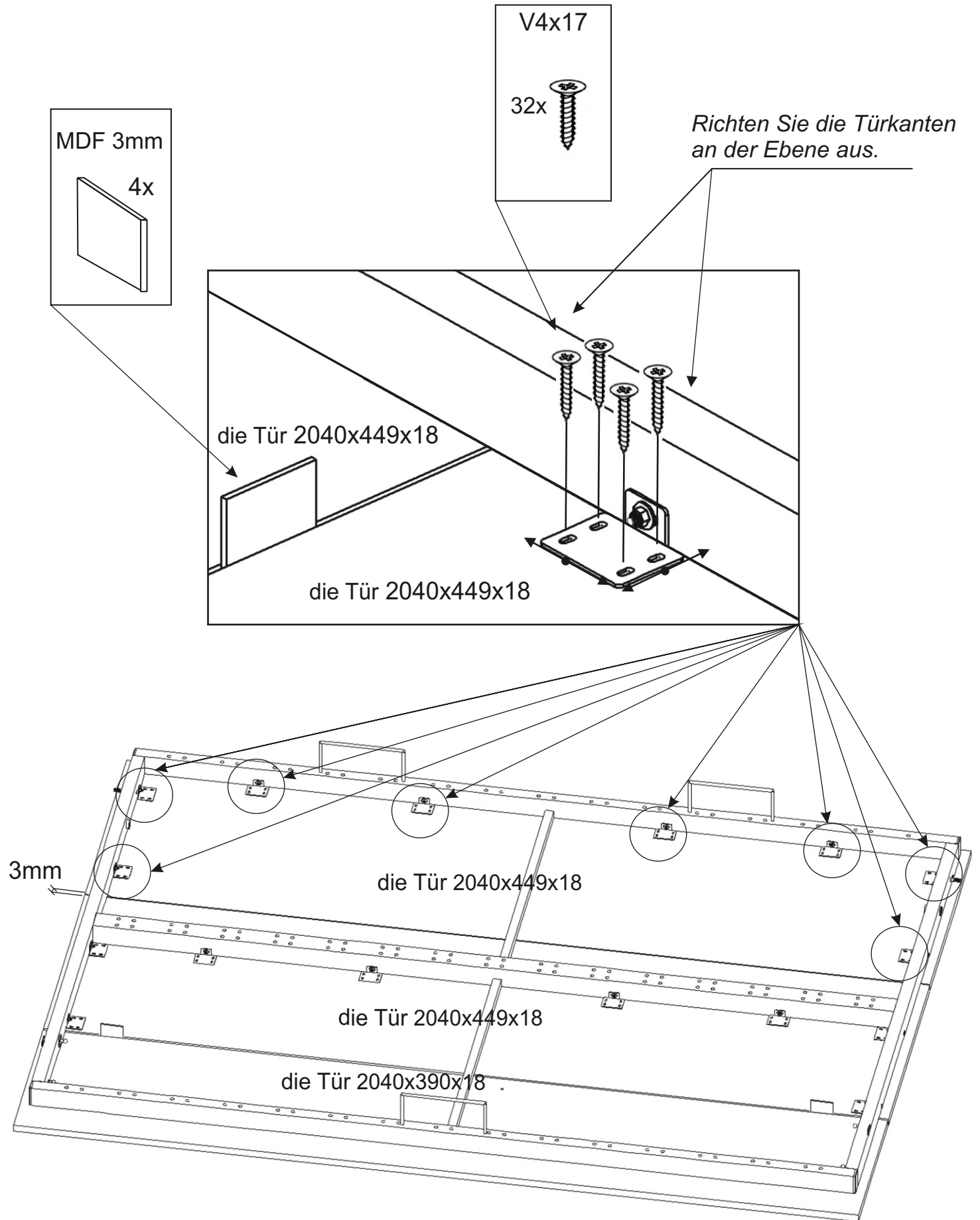

18.

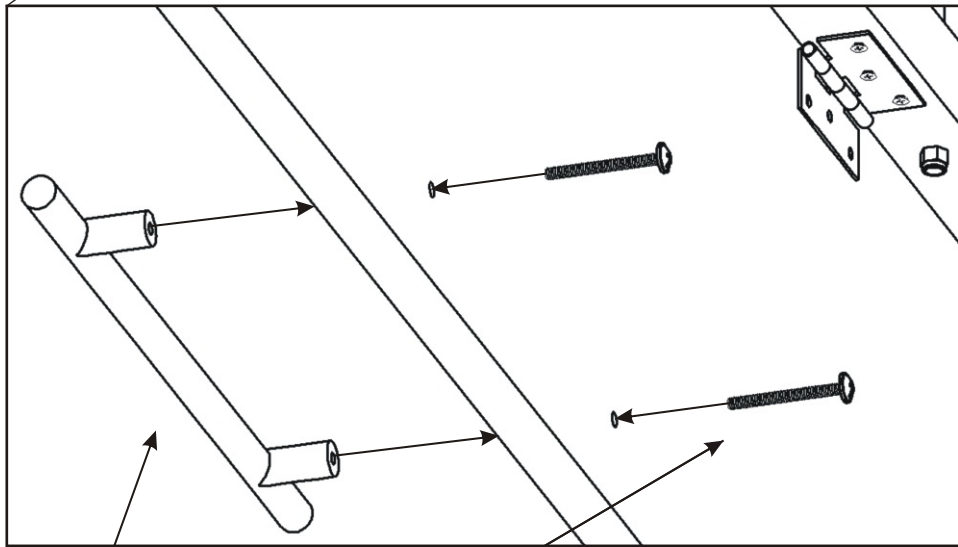
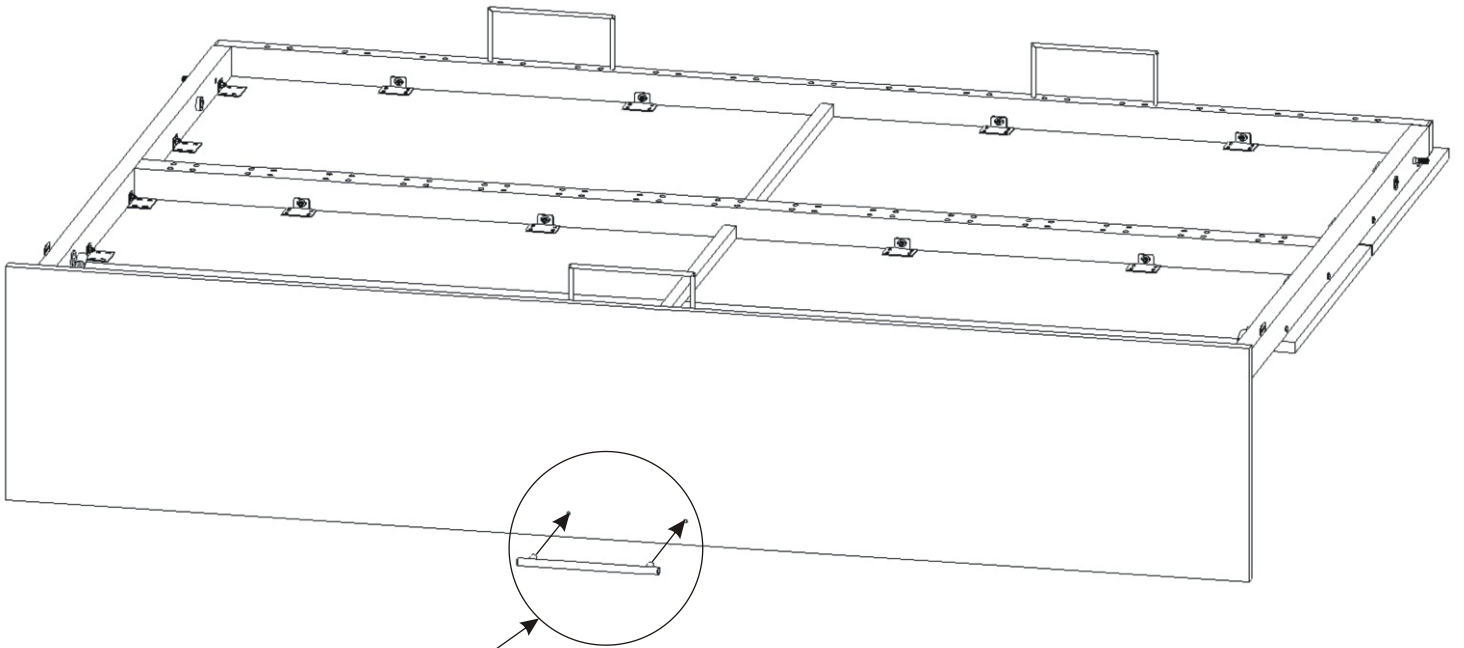

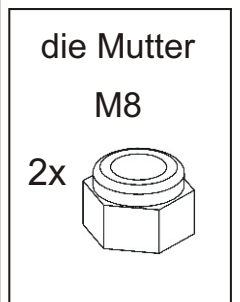
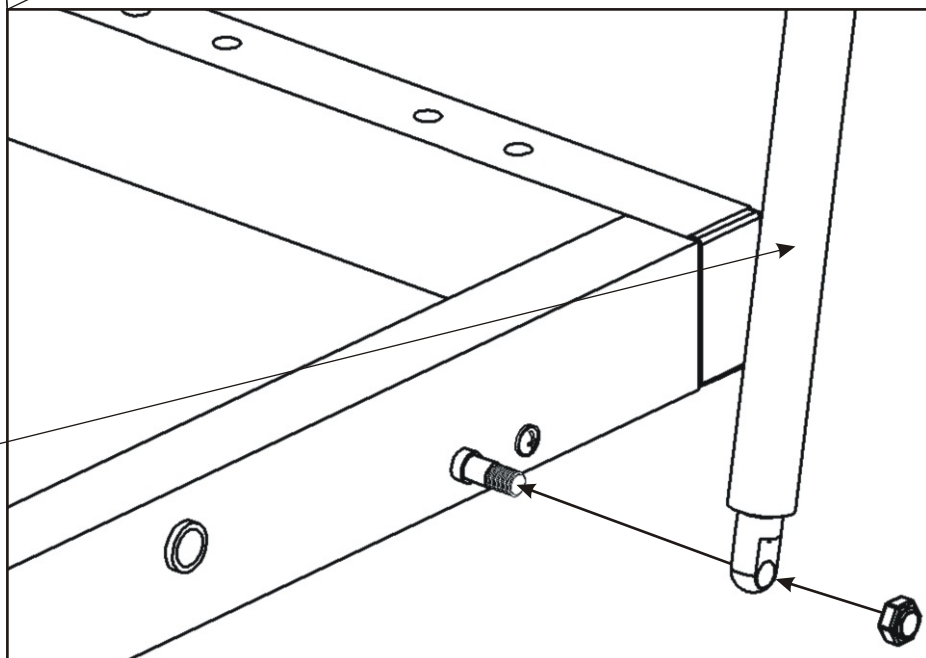
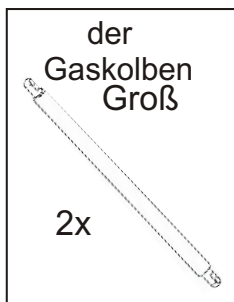
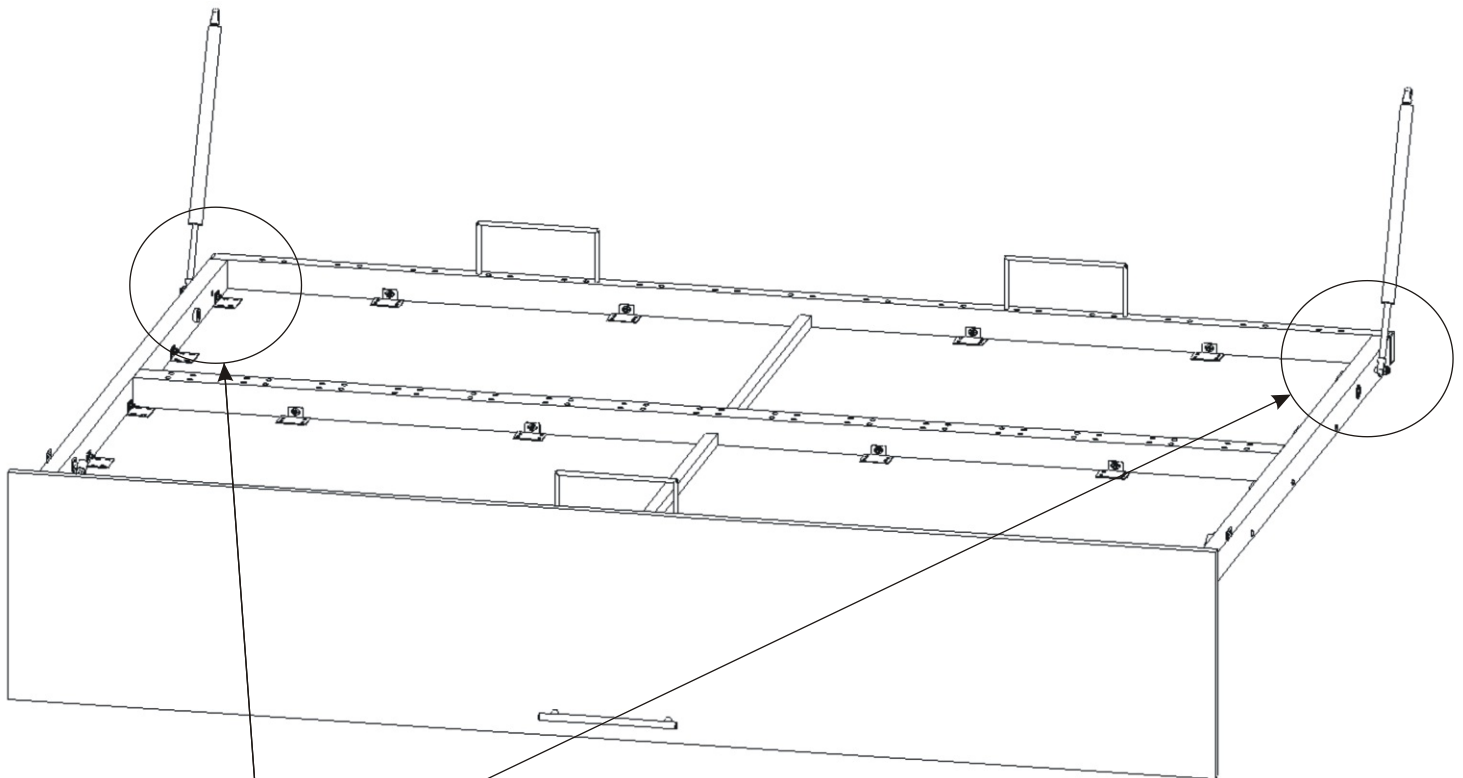

Der große Kolben ist am Rahmen zu montieren und mit einer Mutter zu sichern. Die Mutter darf nicht vollständig angezogen werden, um die notwendige Beweglichkeit des Kolbens zu gewährleisten. Bei unsachgemäßer Fixierung besteht die Gefahr einer irreversiblen Beschädigung des Kolbens.

20.

1. Schieben Sie den Rahmen mit einem Kollegen in den Korpus.
2. Schrauben Sie den Bettrahmen mit einer M12x70-Schraube und einer Unterlegscheibe an die Bodenplatte des Bettkörpers an.

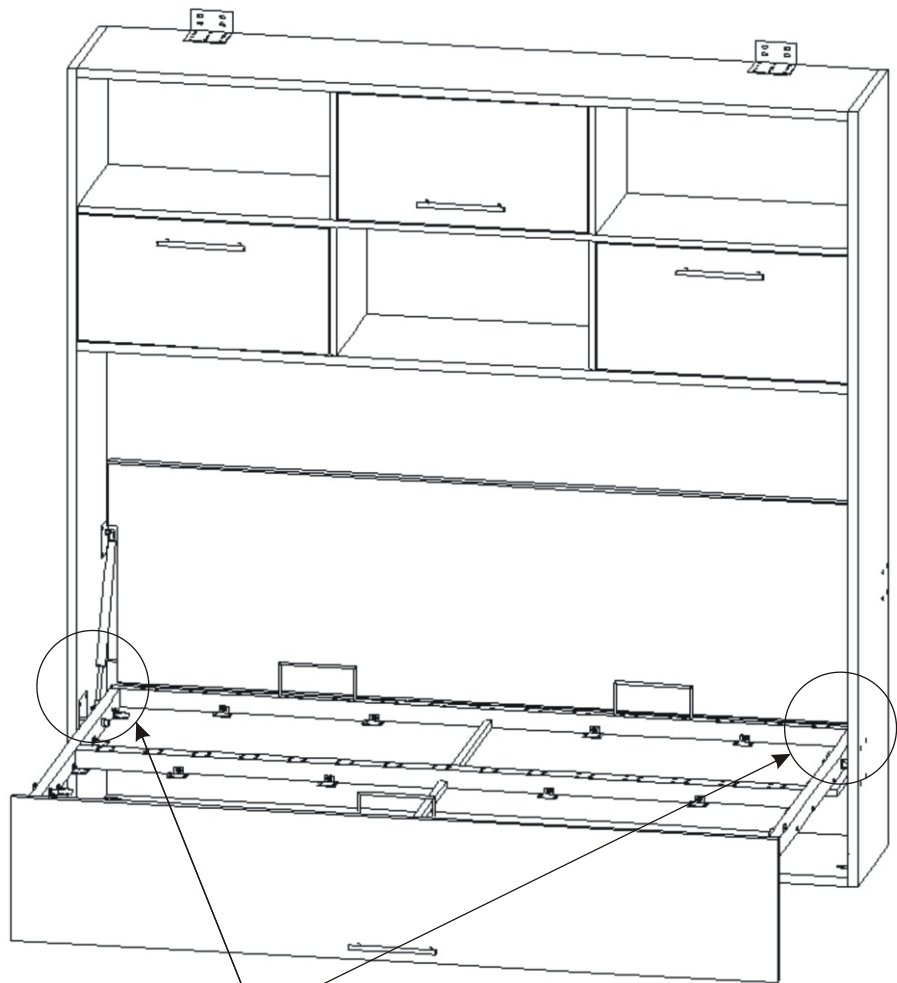

M12x70

2x



die Unterlage
4x M13

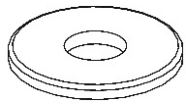

20.1.

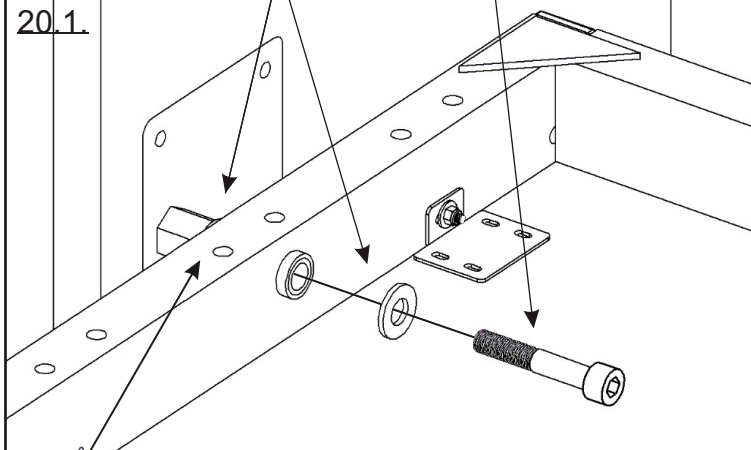

20.2.

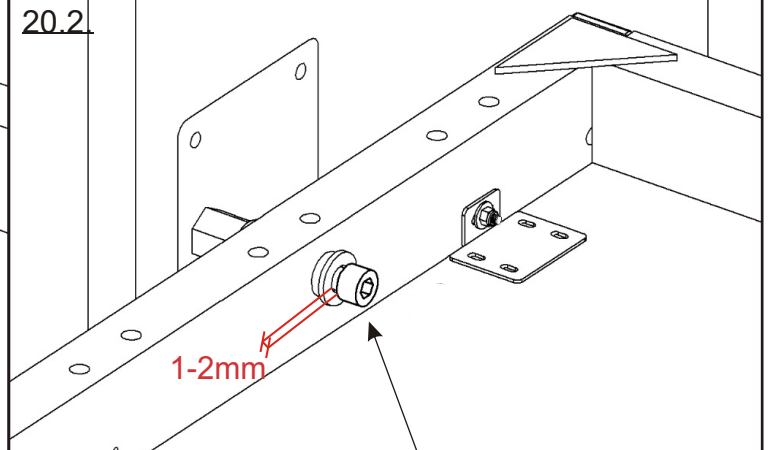

1-2mm

Metall-
kleber
1x

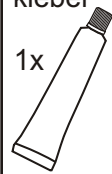

Geben Sie etwas Klebstoff auf die Befestigungsplatte an der Bettseite und schrauben Sie die Schraube M12x70 sofort fest. Sollte das Bett später wieder demontiert werden, lässt sich die Schraube mit etwas mehr Kraft lösen.

Es ist außerdem notwendig, von Zeit zu Zeit zu überprüfen, ob sich die Schraube nicht gelöst hat.

Ziehen Sie die Schraube M12 x 70 nicht vollständig fest. Lassen Sie zwischen Schraubenkopf und Unterlegscheibe ein Spiel von ca. 1-2 mm, um die notwendige Beweglichkeit zu gewährleisten. Wird die Schraube zu fest angezogen, besteht die Gefahr einer irreparablen Beschädigung des Bettrahmens!

21.

Die Kolben werden bei geschlossener Tür montiert.
Die obere Anschlagstange darf nicht montiert werden.
2050x70x25mm.

- 1) Die Türen in die horizontale Position kippen und den gesamten beweglichen Teil nach innen drücken.
- 2) Nun die Kolben lose in die oberen Bolzen einsetzen.

Die Schraube darf nicht vollständig festgezogen werden, da sie ein geringes Spiel für die Drehbewegung haben muss. Andernfalls besteht die Gefahr einer irreparablen Beschädigung des Kolbens!

21.1.

21.2.

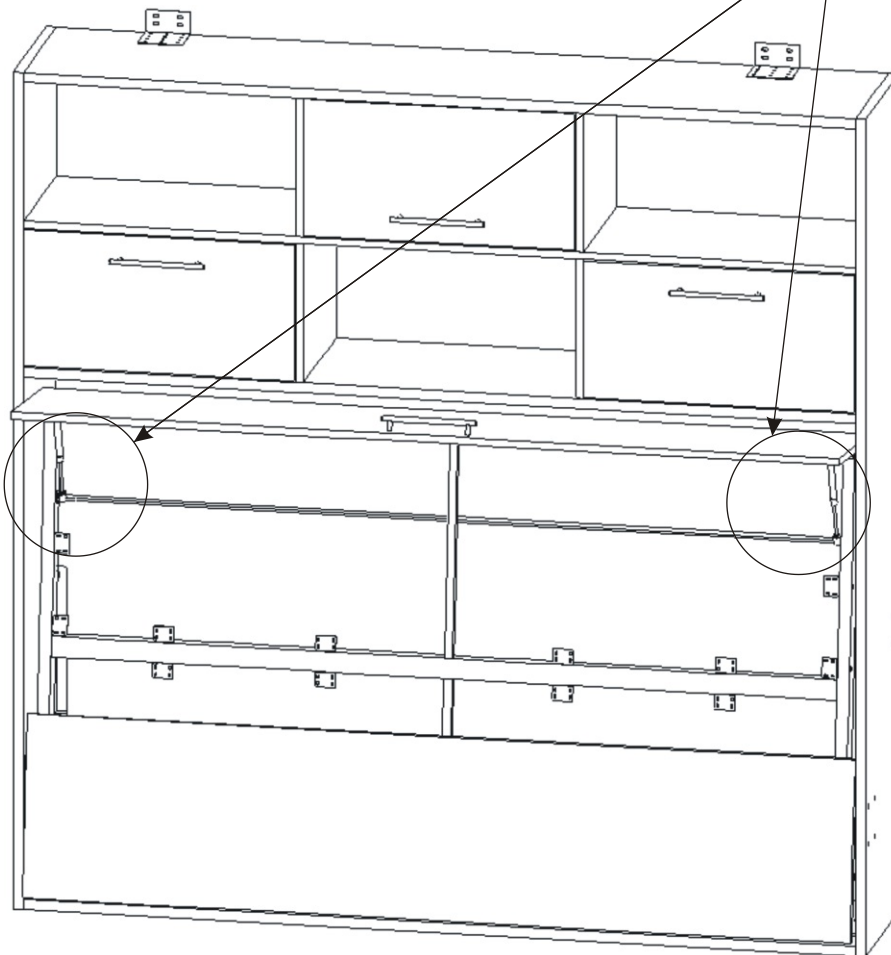

M8x25

2x

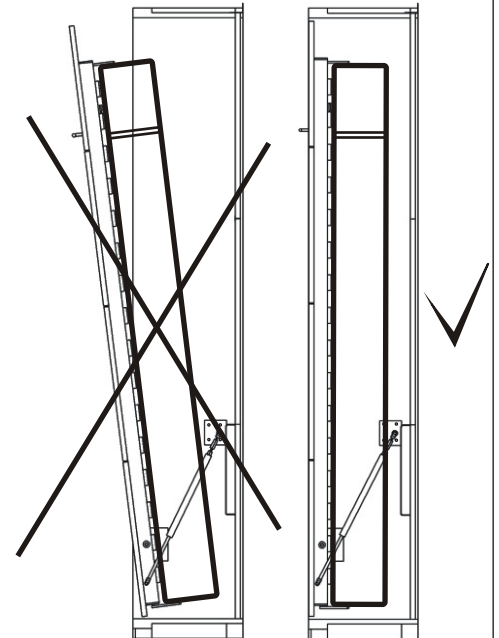

Die Einstellung des Abstands der Kolben

Zur Montage des Klappbettes verwenden Sie die Kolben, die als in der Abbildung A eingestellt sind. Wenn sich die Tür mit der Matratze nicht übereinstimmt, stellen Sie den Kolbenabstand ein, in dem Sie ihn leicht um ca. 1 bis 2mm öffnen. Maximal 2mm!!! Wenn Sie einen größeren Abstand einstellen, werden die Kolben dauerhaft beschädigt. Dieser Schaden werden von der Reklamation abgedeckt.

Ⓐ

Ⓑ

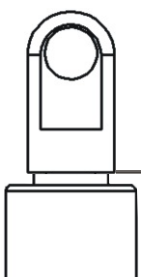

0mm

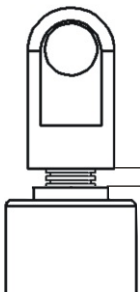

2mm

22.

Richten Sie die Türkanten
an der Ebene aus.

MDF 3mm

4x

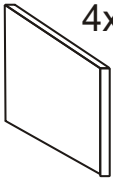

die Tür
2040x449x18

V3,5x16

16x



V4x17

48x



die Tür
2040x449x18

Aufhänge-
vorrichtungen
82x12

4x

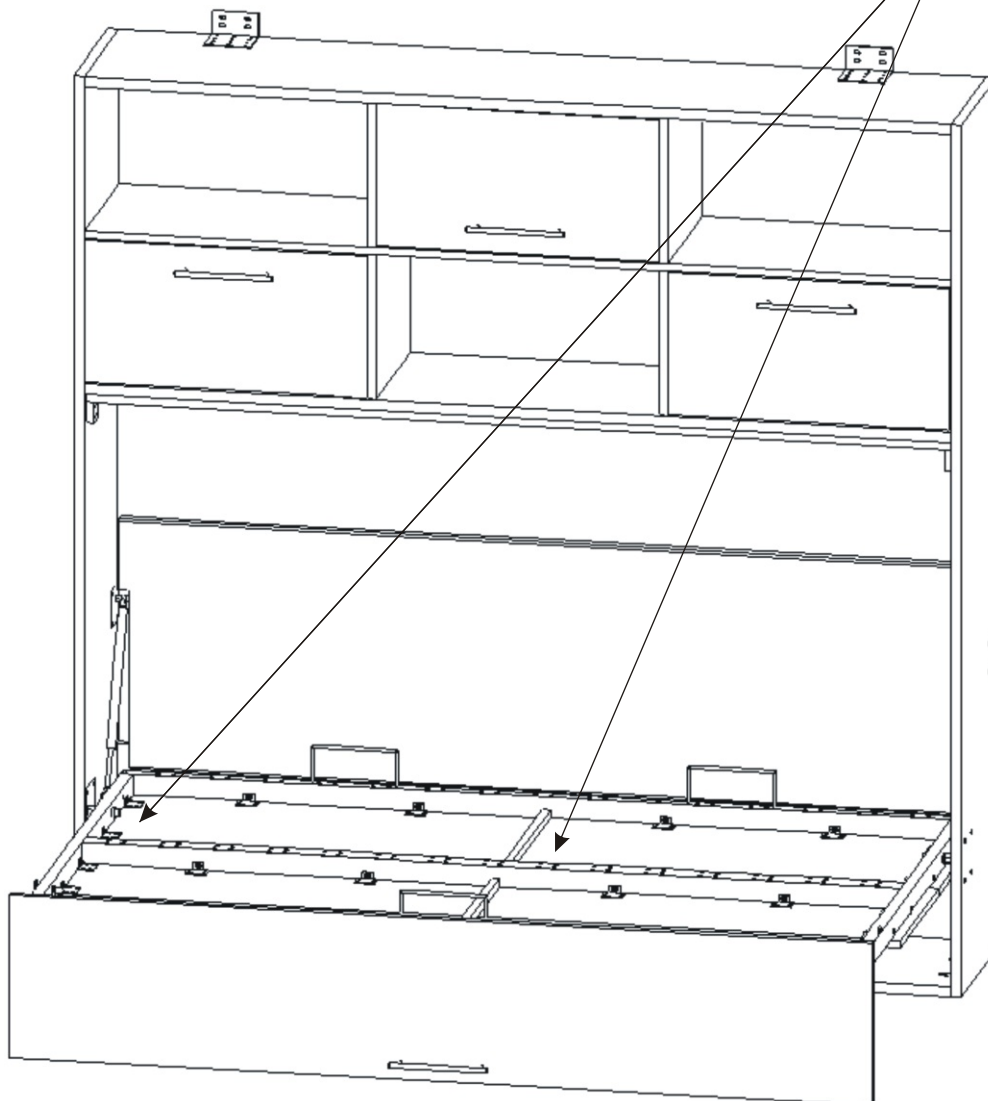
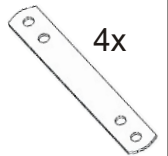

Befestigen Sie die Stoppleiste 20mm von der Vorderkante.
Die Stoppleiste wird erst nach dem Anbringen des Rahmens und der Kolbenn befestigt.

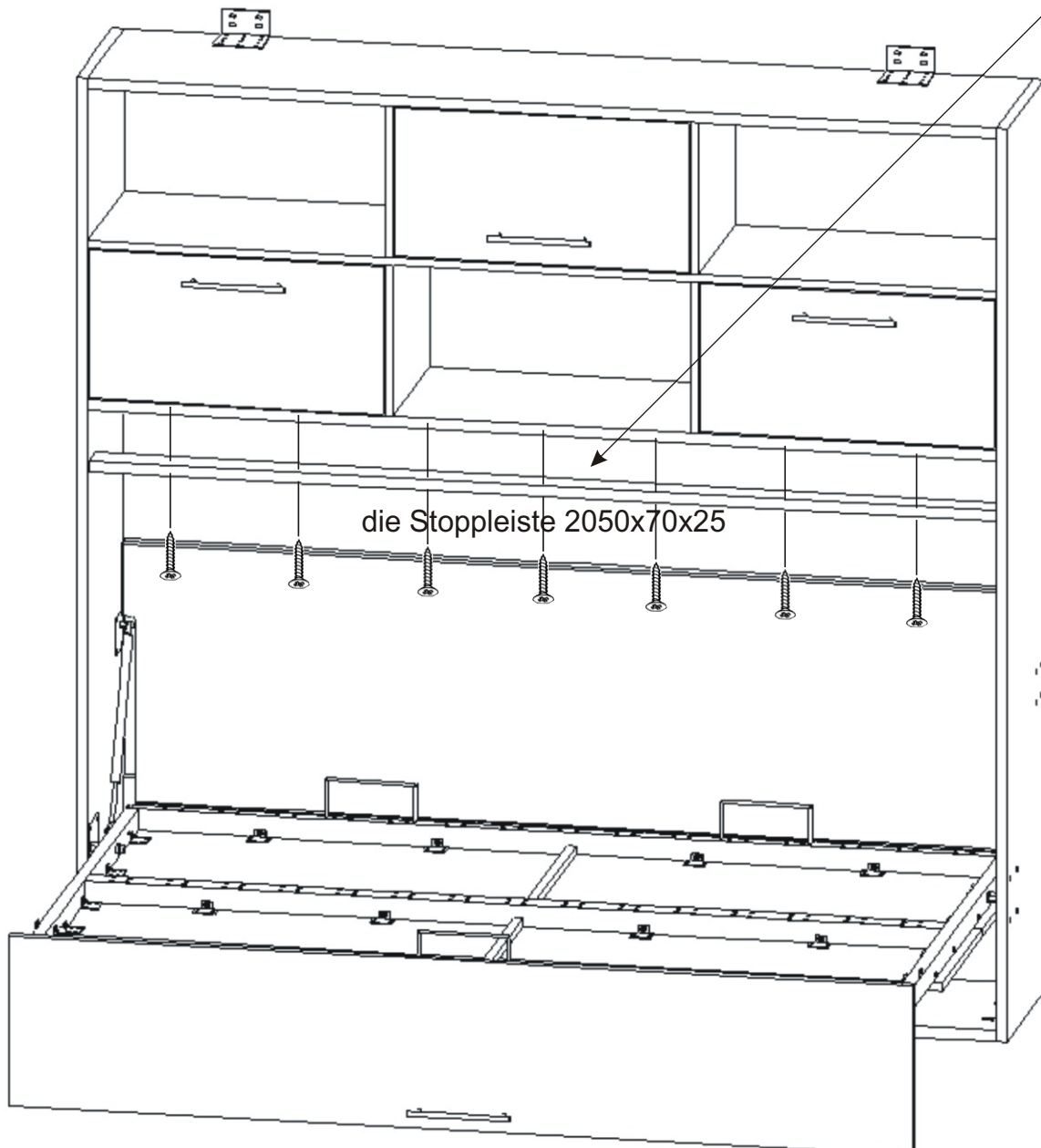
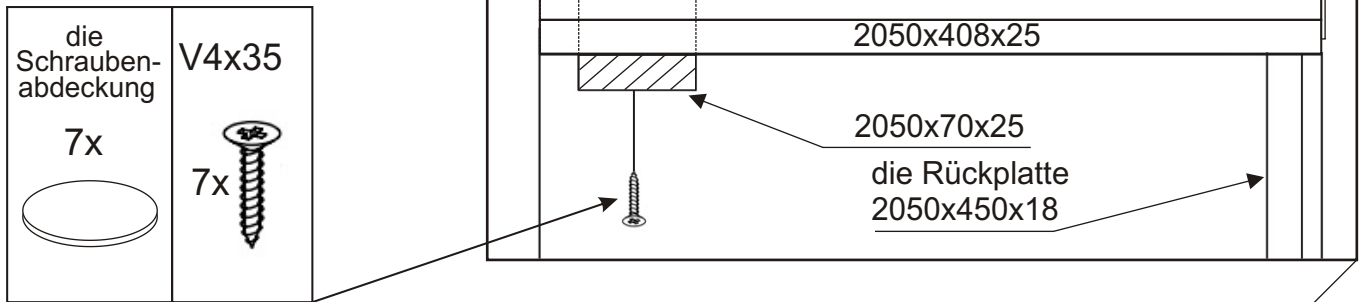

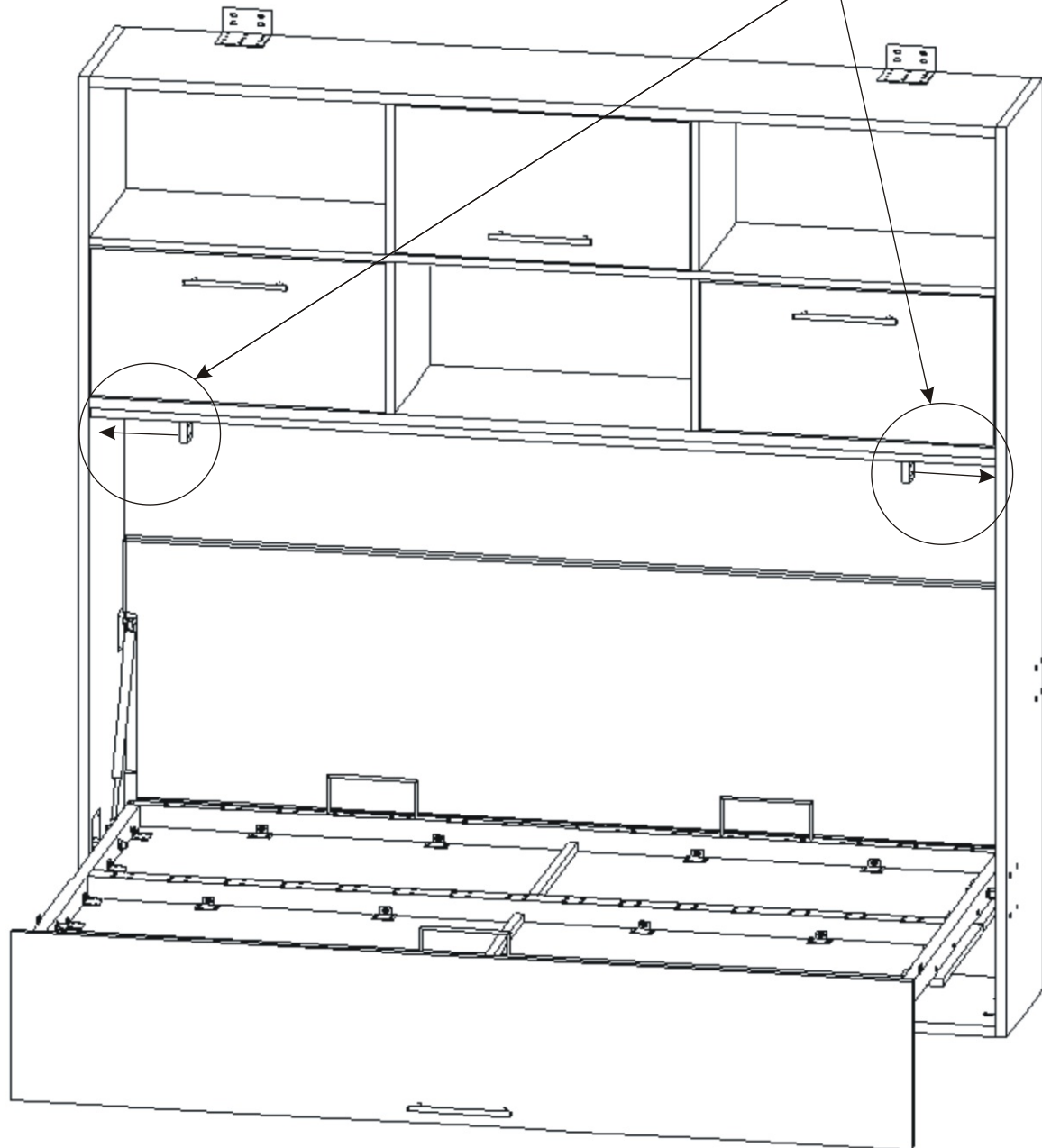
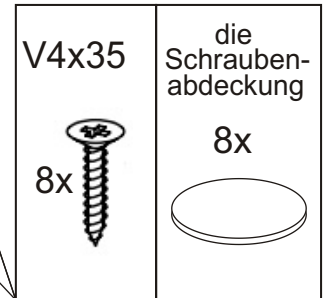
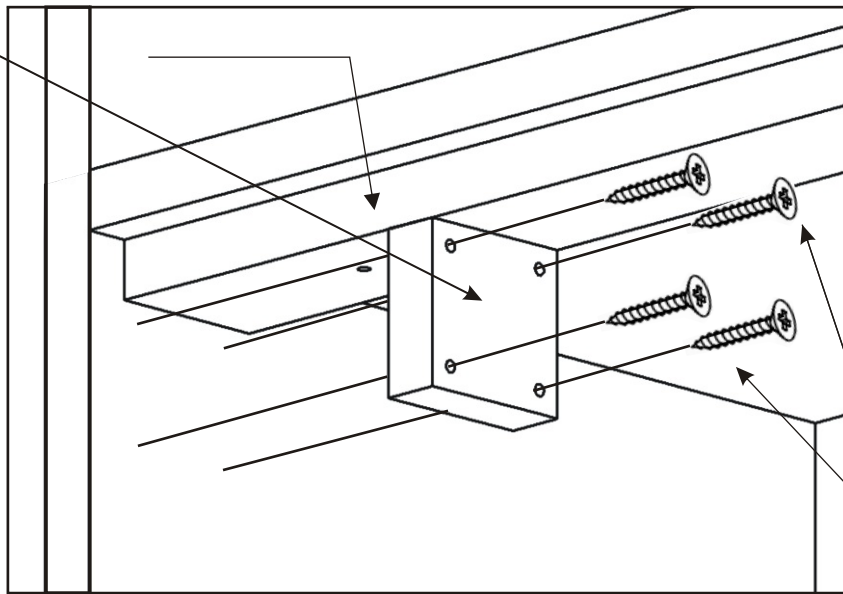
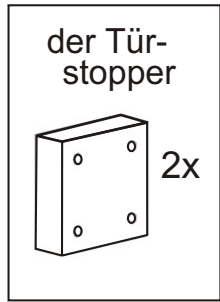

25.

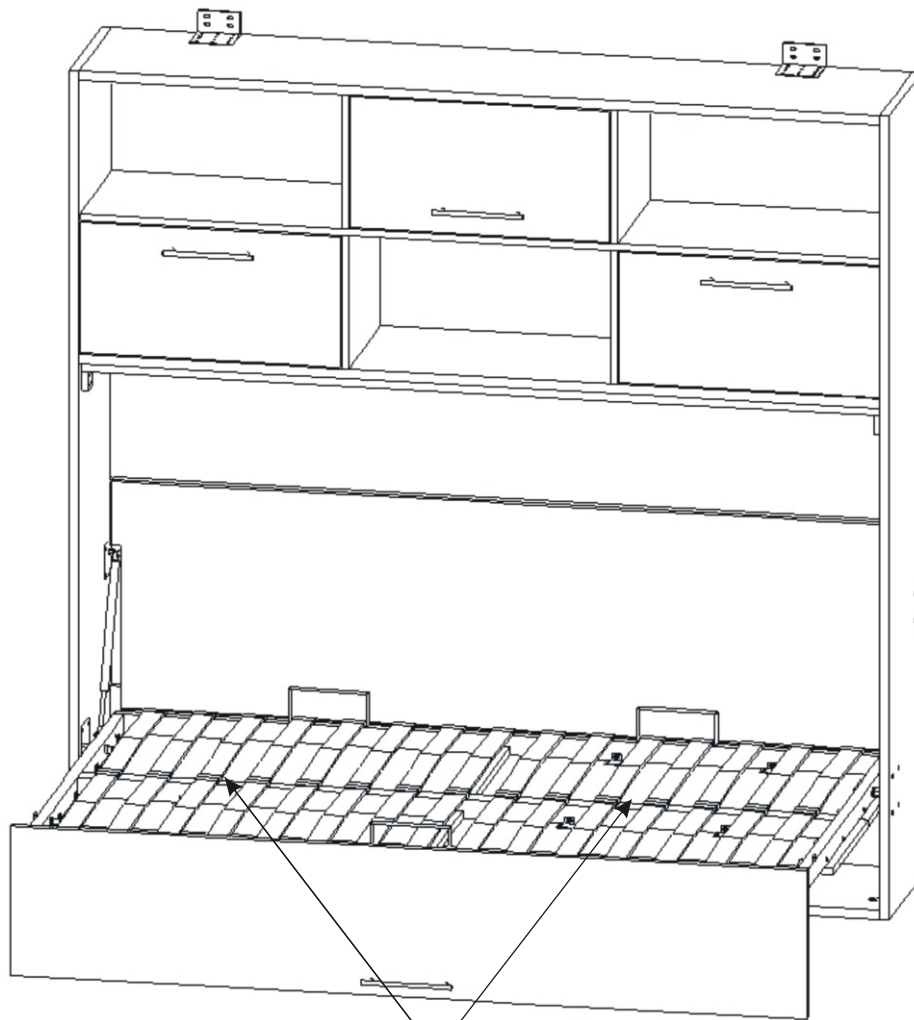

25.1.

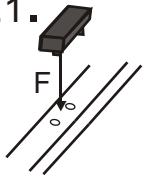

25.2.



25.3.

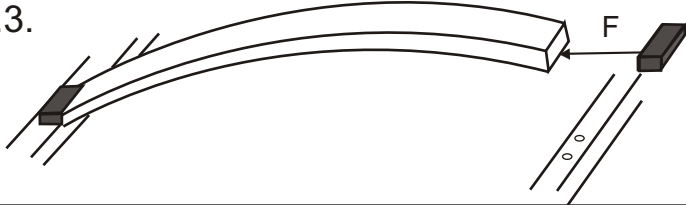

25.4.

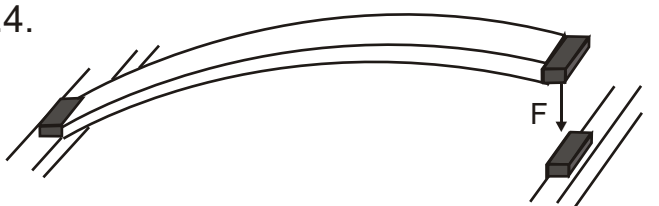

25.5.



Die
Lamellenhalter

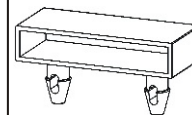

30x

die Lamelle
585mm

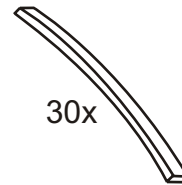

30x

Die
Lamellenhalter

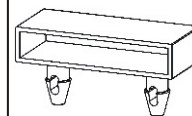

30x

