

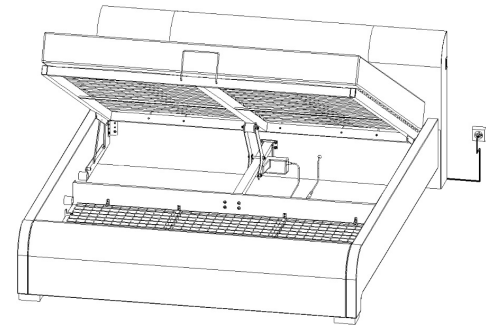

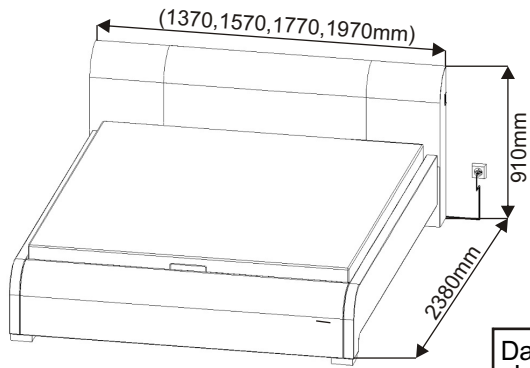

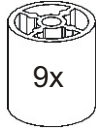

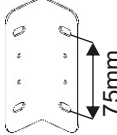



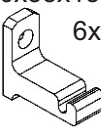
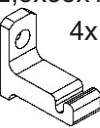





SEINA MOT 120,140,160,180

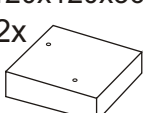
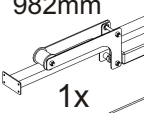

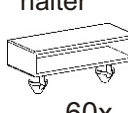
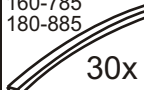
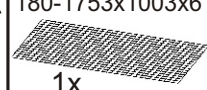
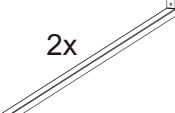
die Walze ø47x47 9x 	der Winkel 120x45x45 6x 	der Stift 35mm 6x 	der Kleber 	Haken aus Kunststoff 40x35x15 6x 	Haken aus Kunststoff 32,5x35x15 4x 		
die Schraube M6x30 30x 	die Schraube M6x35 13x 	die Senkschraube M6x35 2x 	die Schraube M6x16 4x 	die Mutter M6 U 120-140-10x U 160-180-12x 	V3,5x16 10x 	V 4x20 32x 	V 4x50 4x 

Das Fußende des Bettes 120x120x36 2x 	der Motor 982mm 1x 	die Unterlage ø 6,3 17x 	die Lamellen- halter 60x 	die Lamelle 120-585 140-685 160-785 180-885 30x 	der Drahtkorb 120-1153x1003x6 140-1353x1003x6 160-1553x1003x6 180-1753x1003x6 1x 
die Strebe 1050mm 2x 	der Matratzen- halter U 120-140-2x U 160-180-3x 140mm 	der Matratzen- halter U 120-180-1x 160mm 	der Deckel 50x30 4x 	Rahmen mit Mechanik 120-1195x1985x50 140-1395x1985x50 160-1595x1985x50 180-1795x1985x50 1x 	

1.

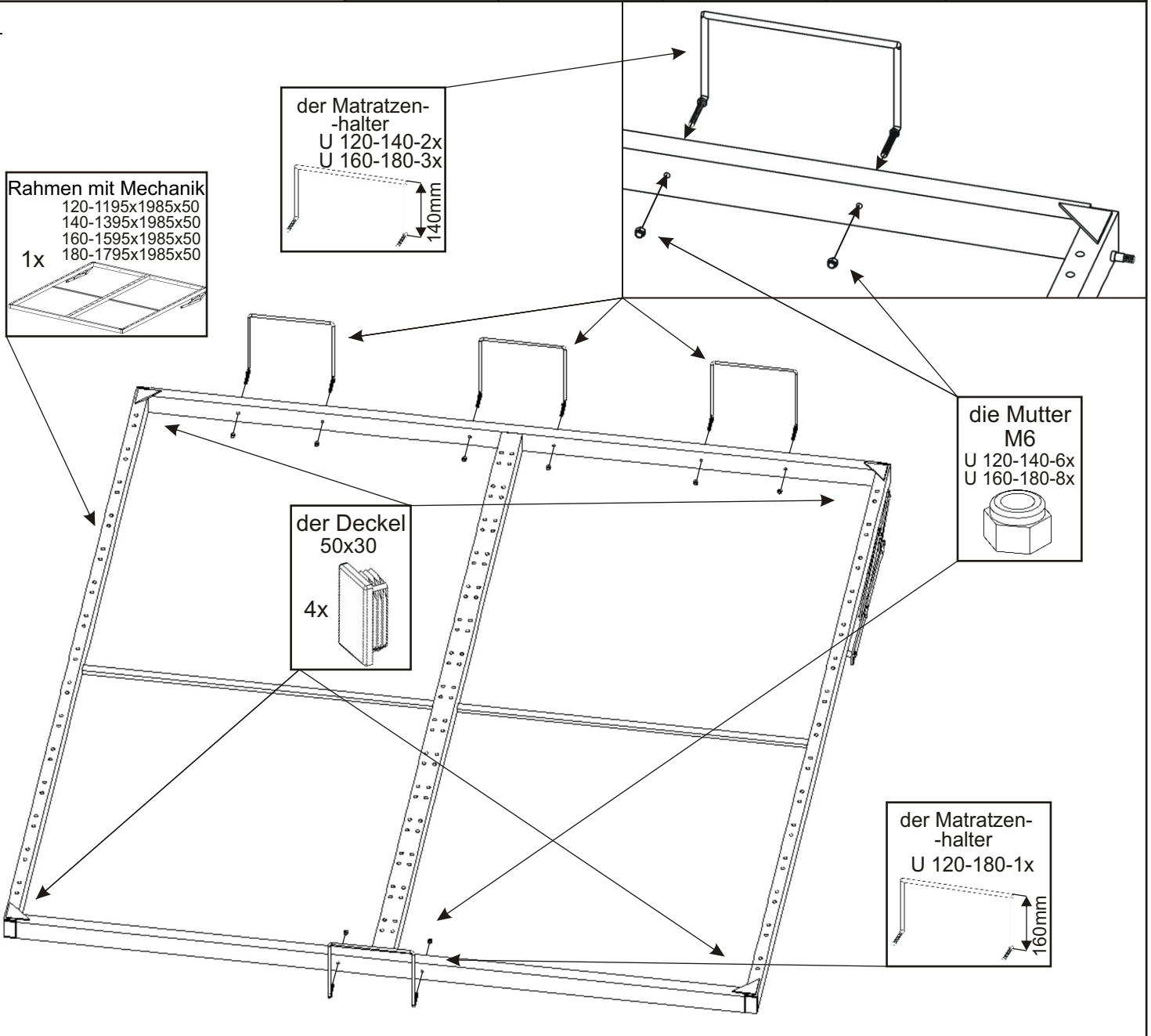

2.

die Schraube M6x35
9x

die Unterlage \varnothing 6,3
9x

die Walze \varnothing 47x47
9x

V 4x50
2x

Haken aus Kunststoff 32,5x35x15
4x

V3,5x16
4x

Das Fußende des Bettes 120x120x36
2x

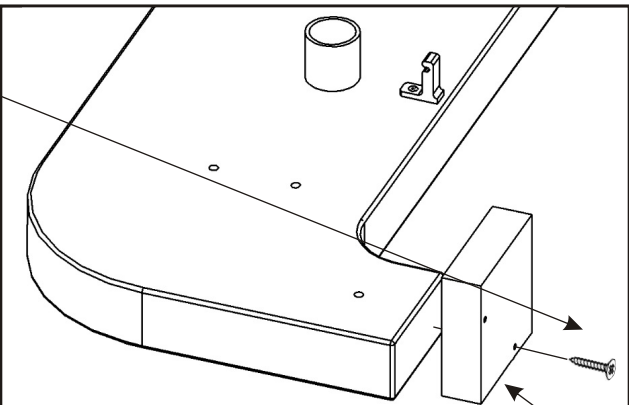
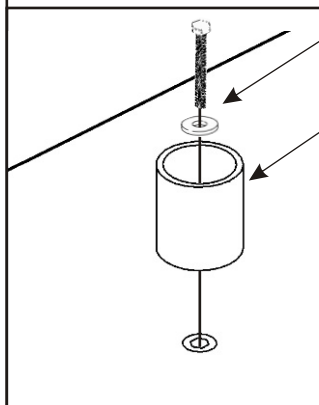

der Stift 35mm
6x

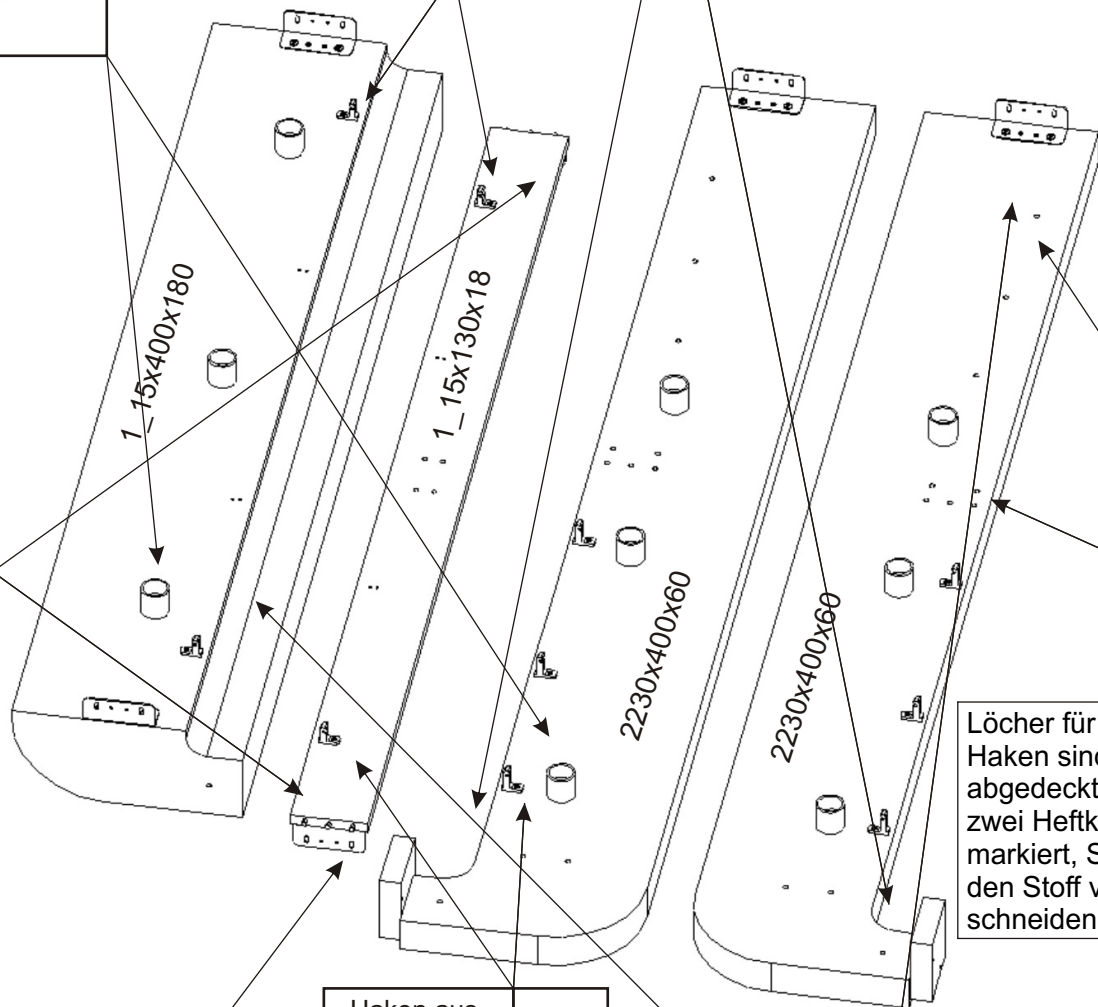

Löcher für Schrauben und Haken sind mit Stoff abgedeckt. Sie sind mit zwei Heftklammern markiert, Sie müssen den Stoff vorsichtig schneiden.

die Schraube M6x16
4x

Haken aus Kunststoff 40x35x15
6x

V3,5x16
6x

die Schraube M6x30
8x

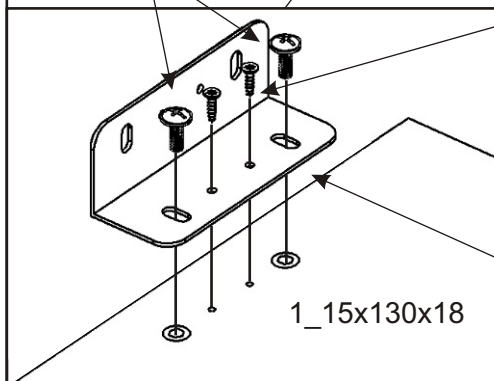

V 4x20
12x

der Winkel 120x45x45
6x
75mm

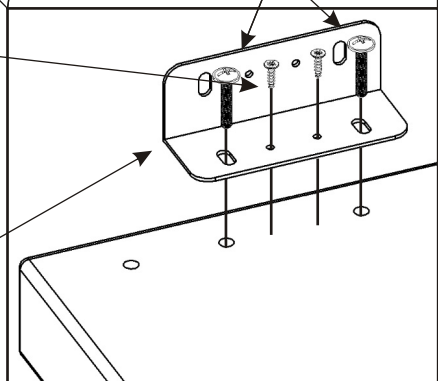

3.

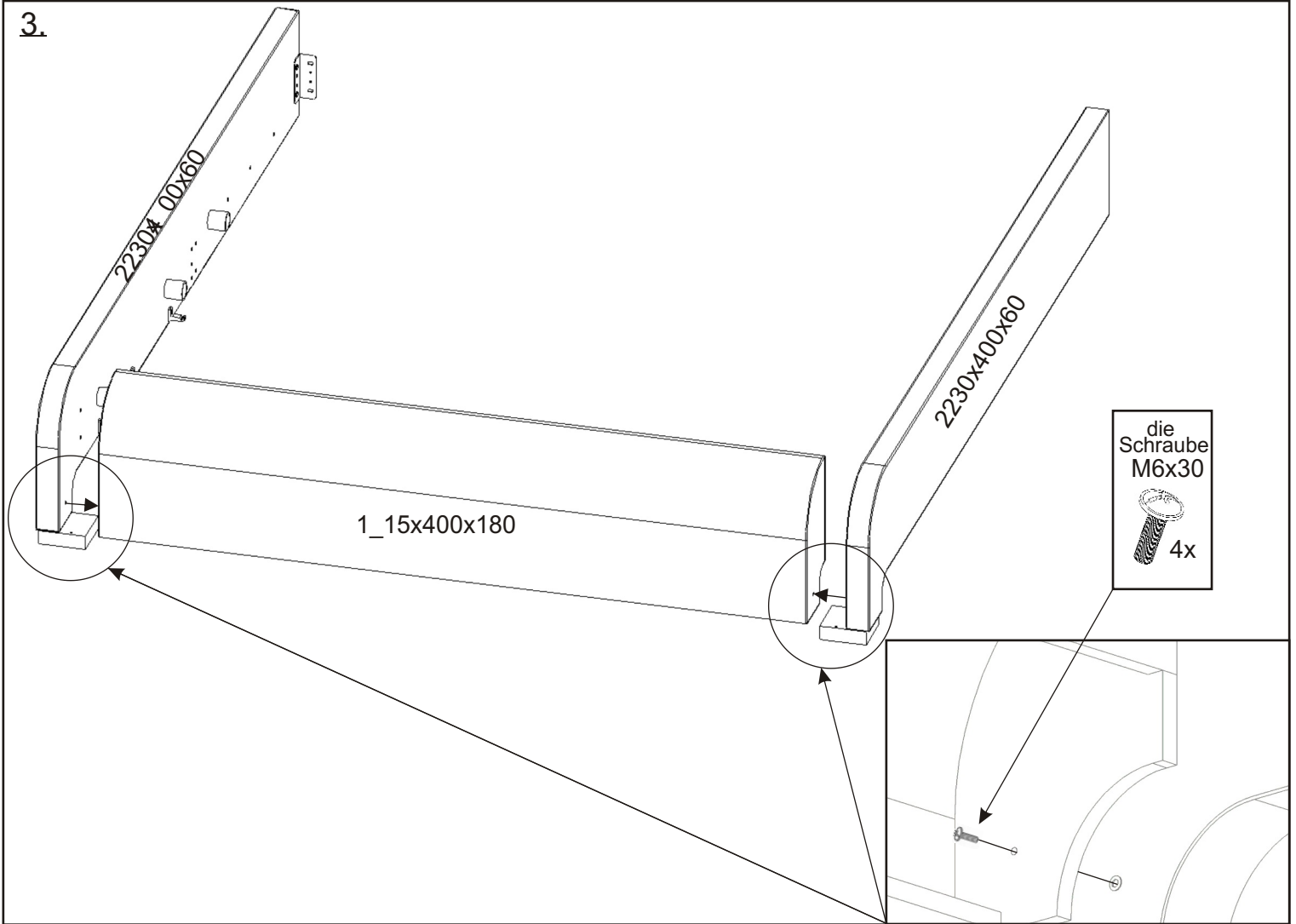

4.

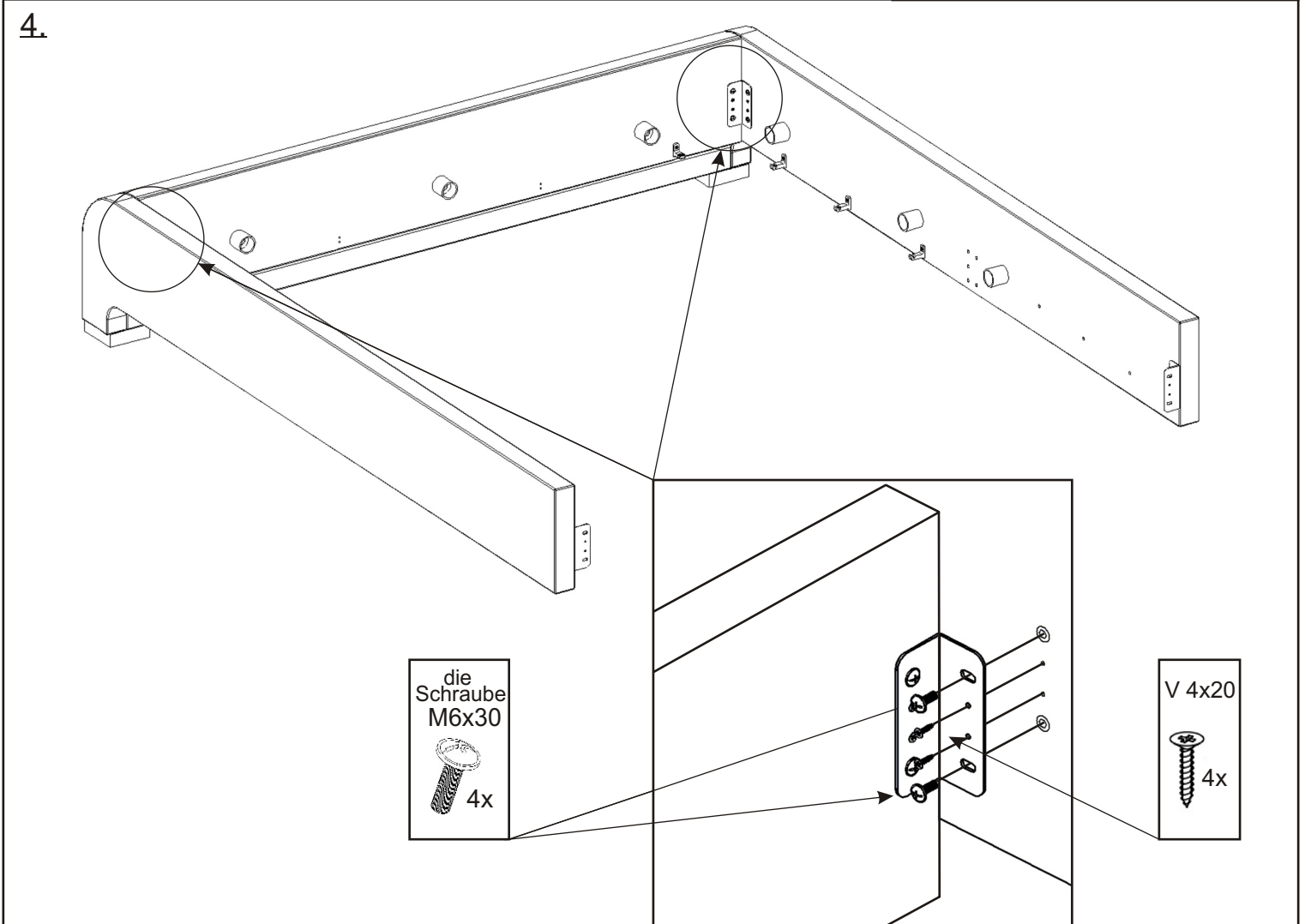

5.

Heben Sie das Bett etwas an und schrauben Sie die 4x50 Schraube, 2 Stück, von unten auf den Bettfuß.

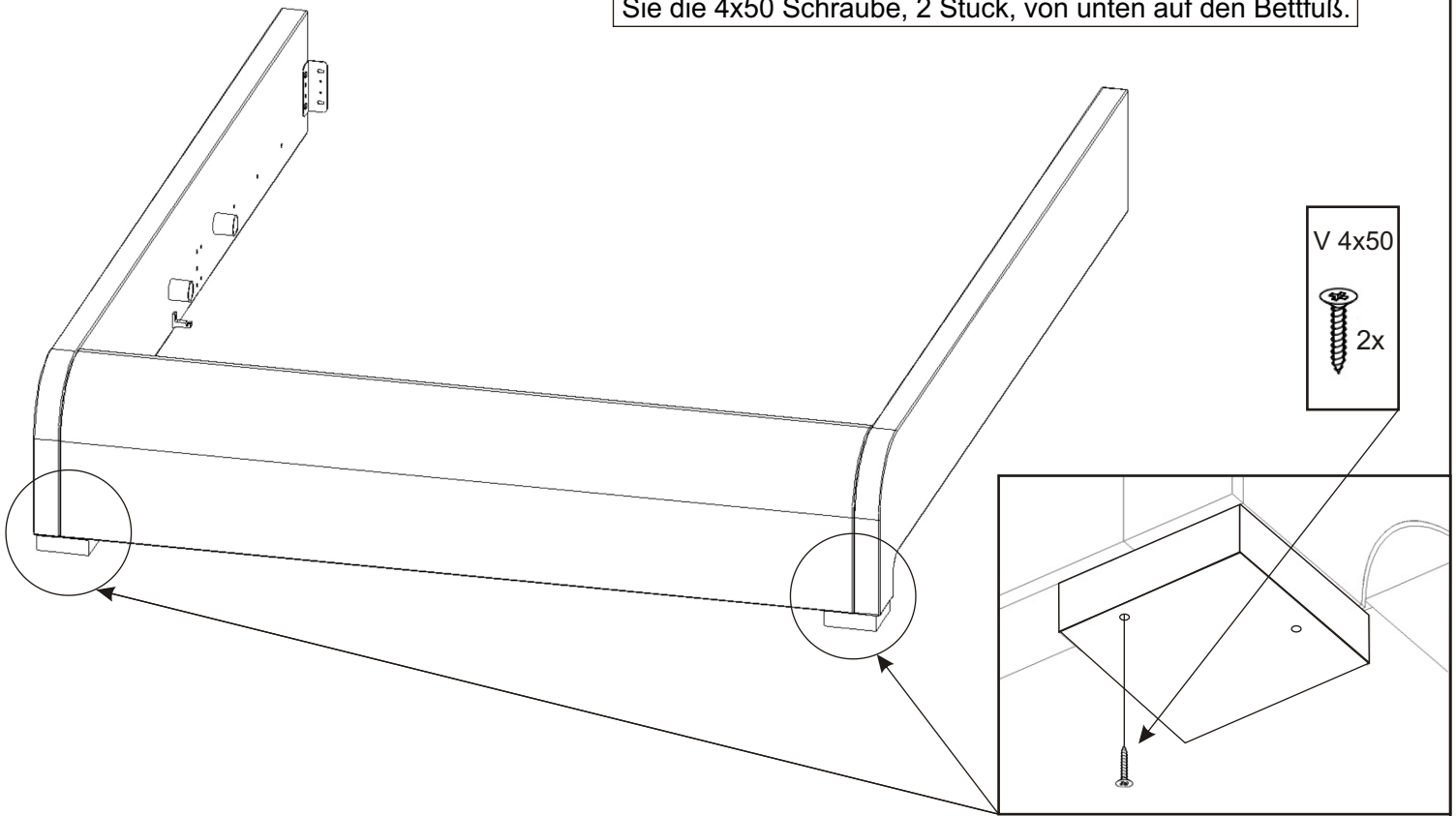

6.

Für eine einfache Demontage muss kein Klebstoff verwendet werden.

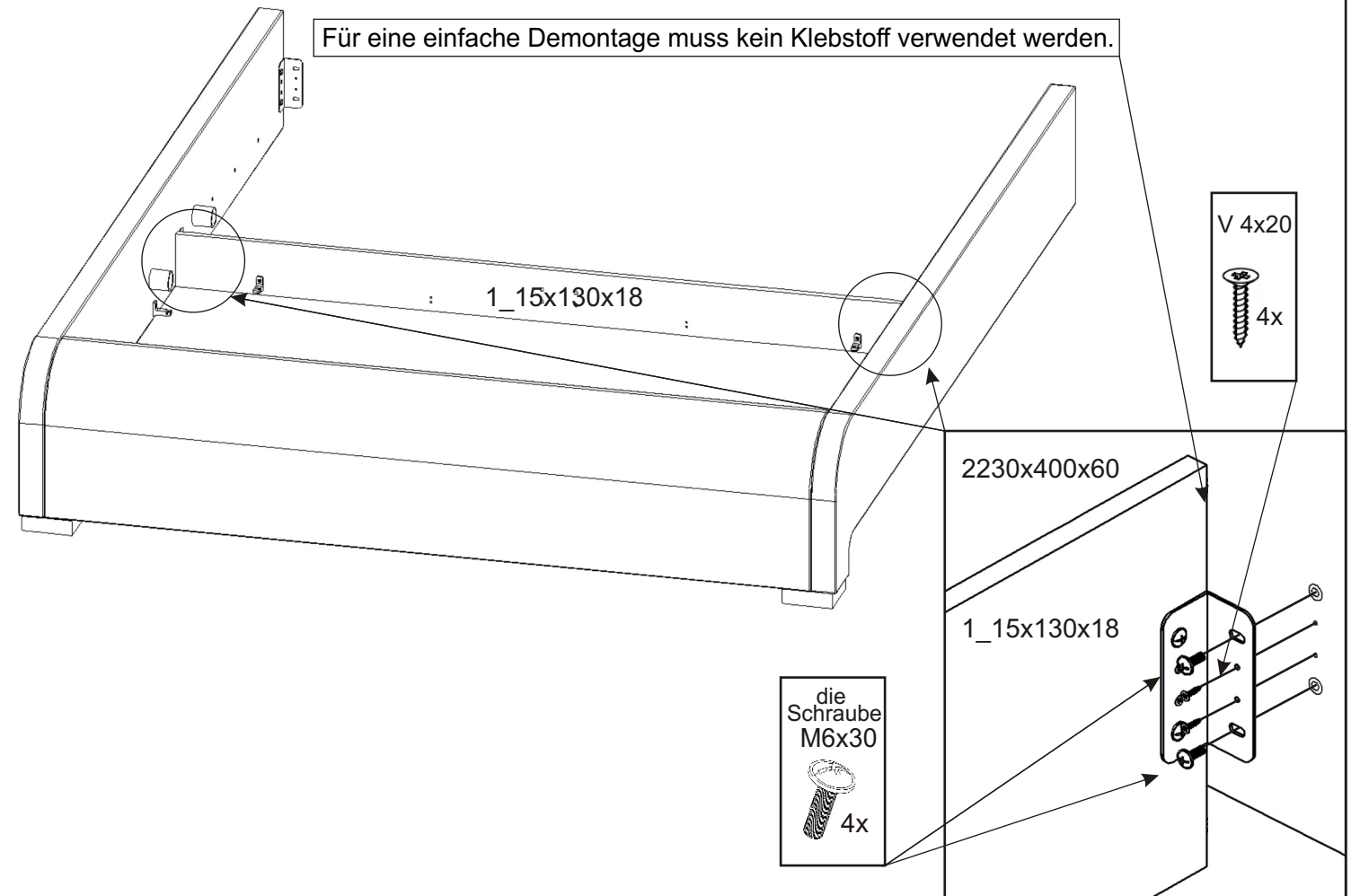

7.

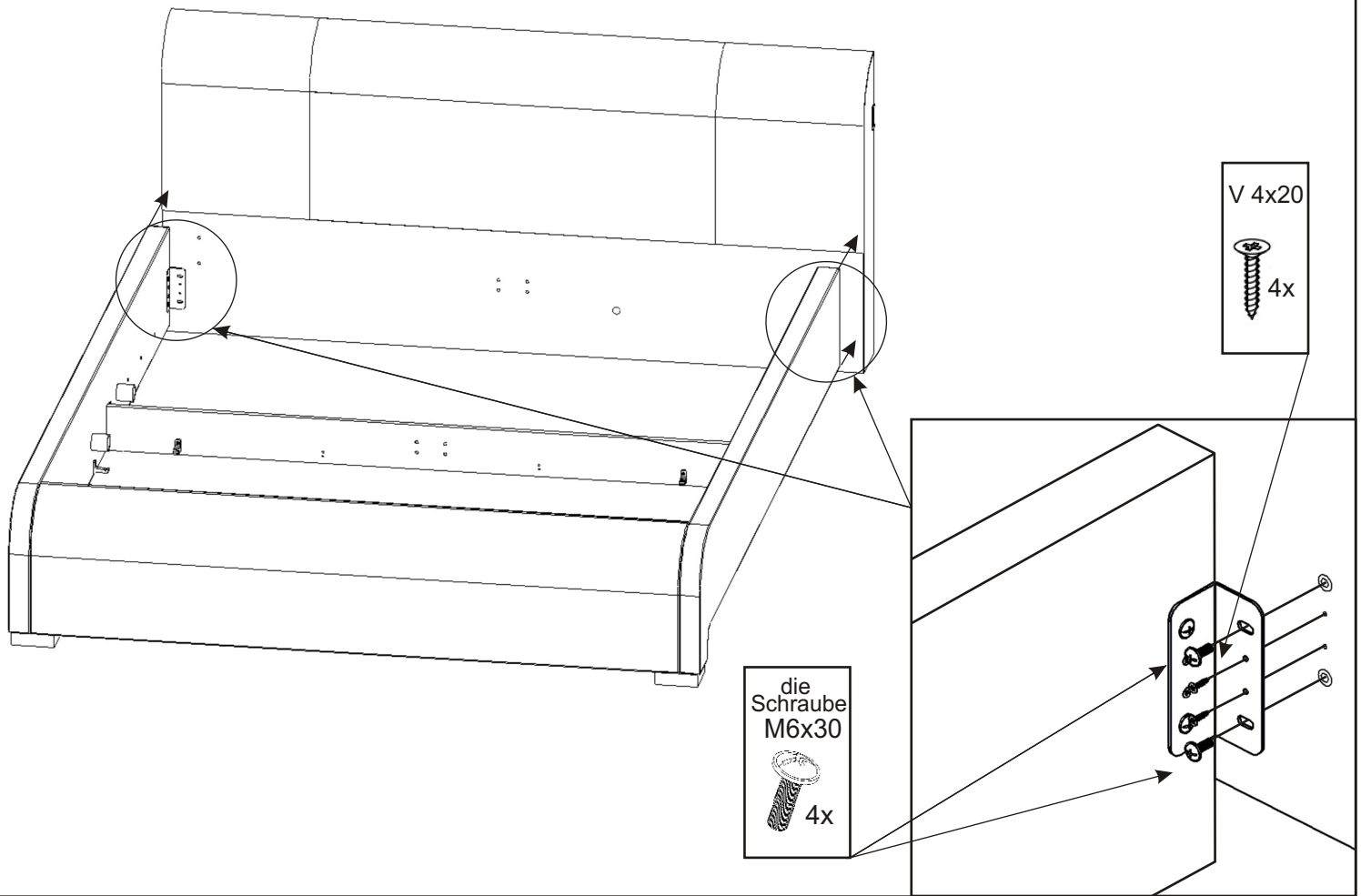

8.

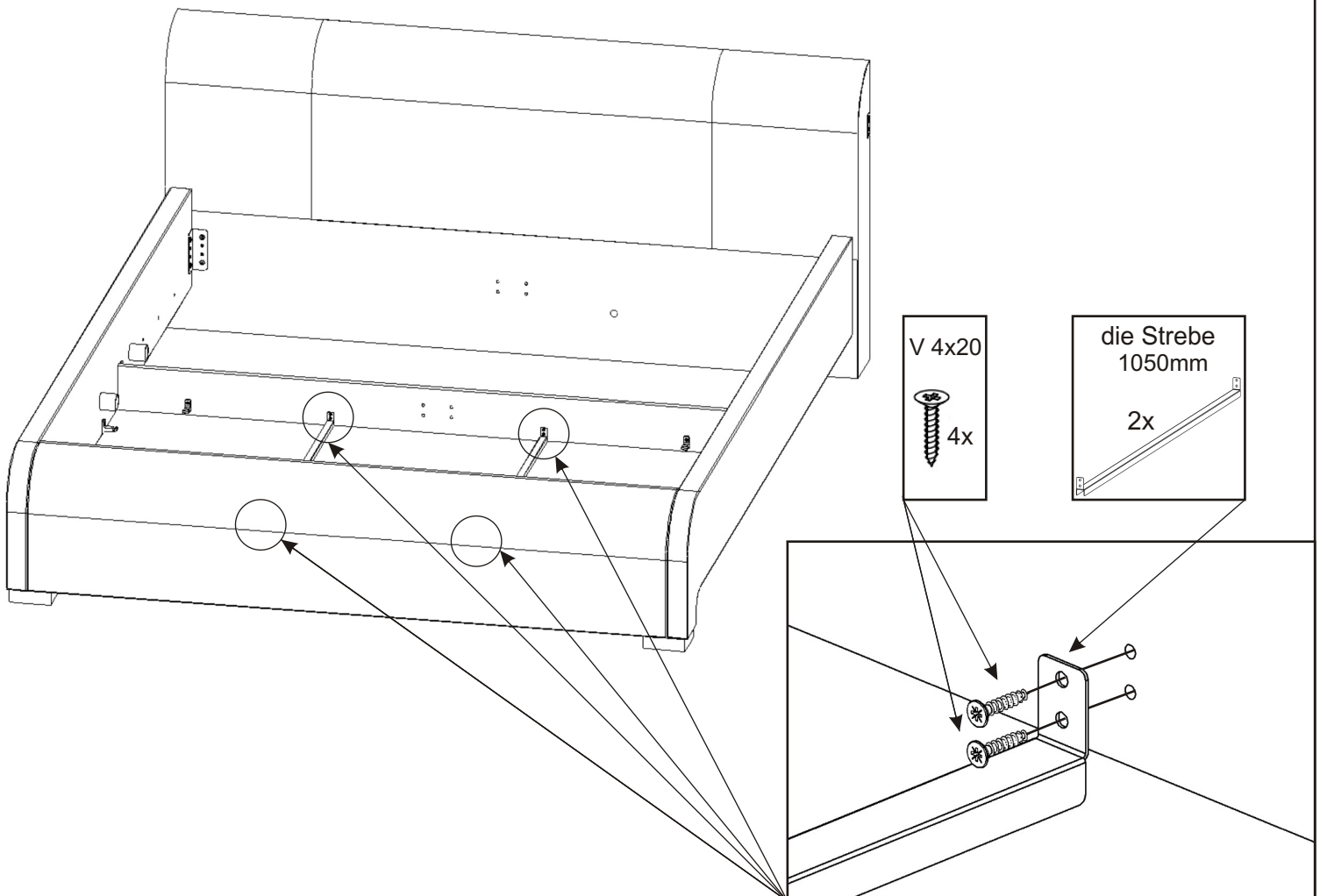

9.

9.1.

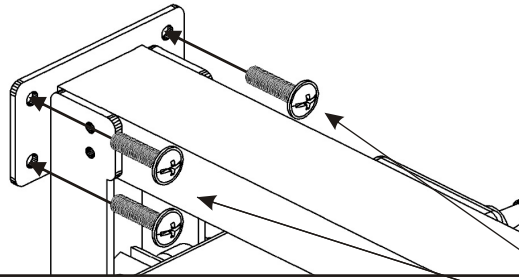

die
Schraube
M6x30
4x

der Motor
982mm
1x

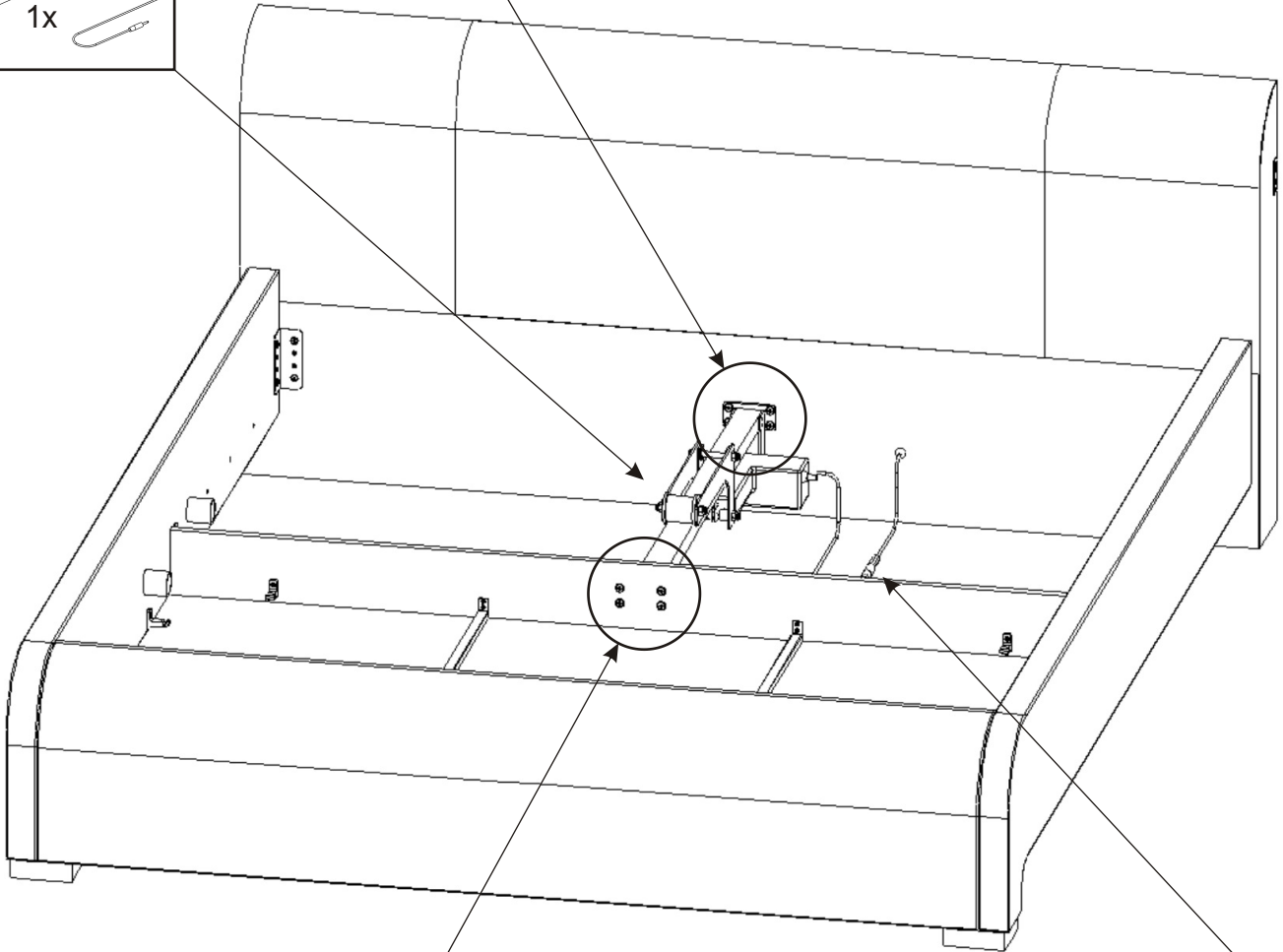

9.3.

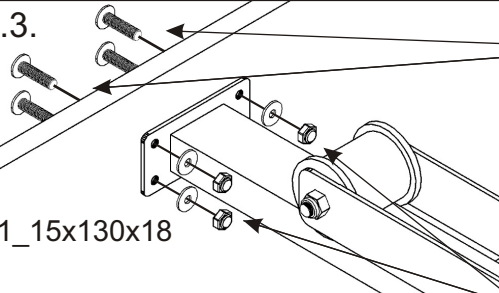

1_15x130x18

die
Schraube
M6x30
4x

9.4.

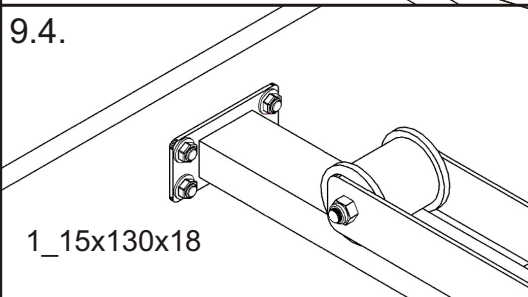

1_15x130x18

die Mutter
M6
4x

die Unterlage
ø 6,3
4x

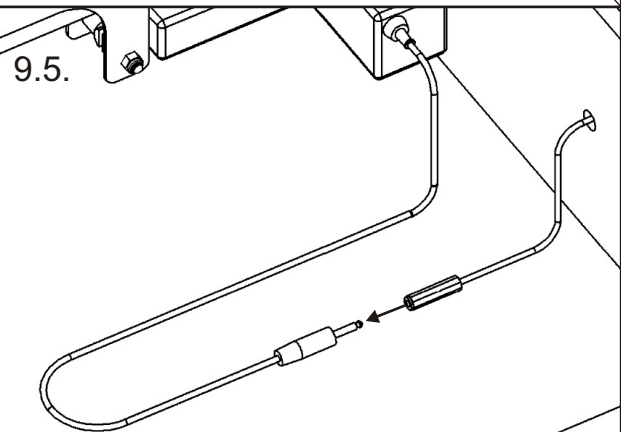



9.5.

Jetzt verbinden wir das Motorkabel mit dem Kabel der Steuergerät.

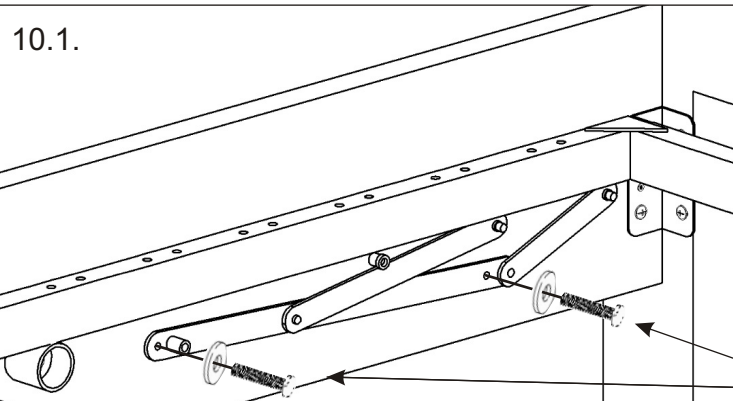
10.



die Schraube M6x35  4x	die Unterlage Ø 6,3 4x 
---	--

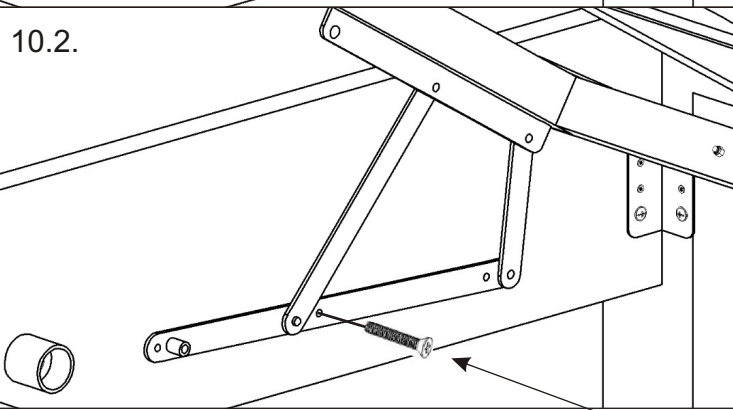

die Senks- Schraube M6x35 2x 

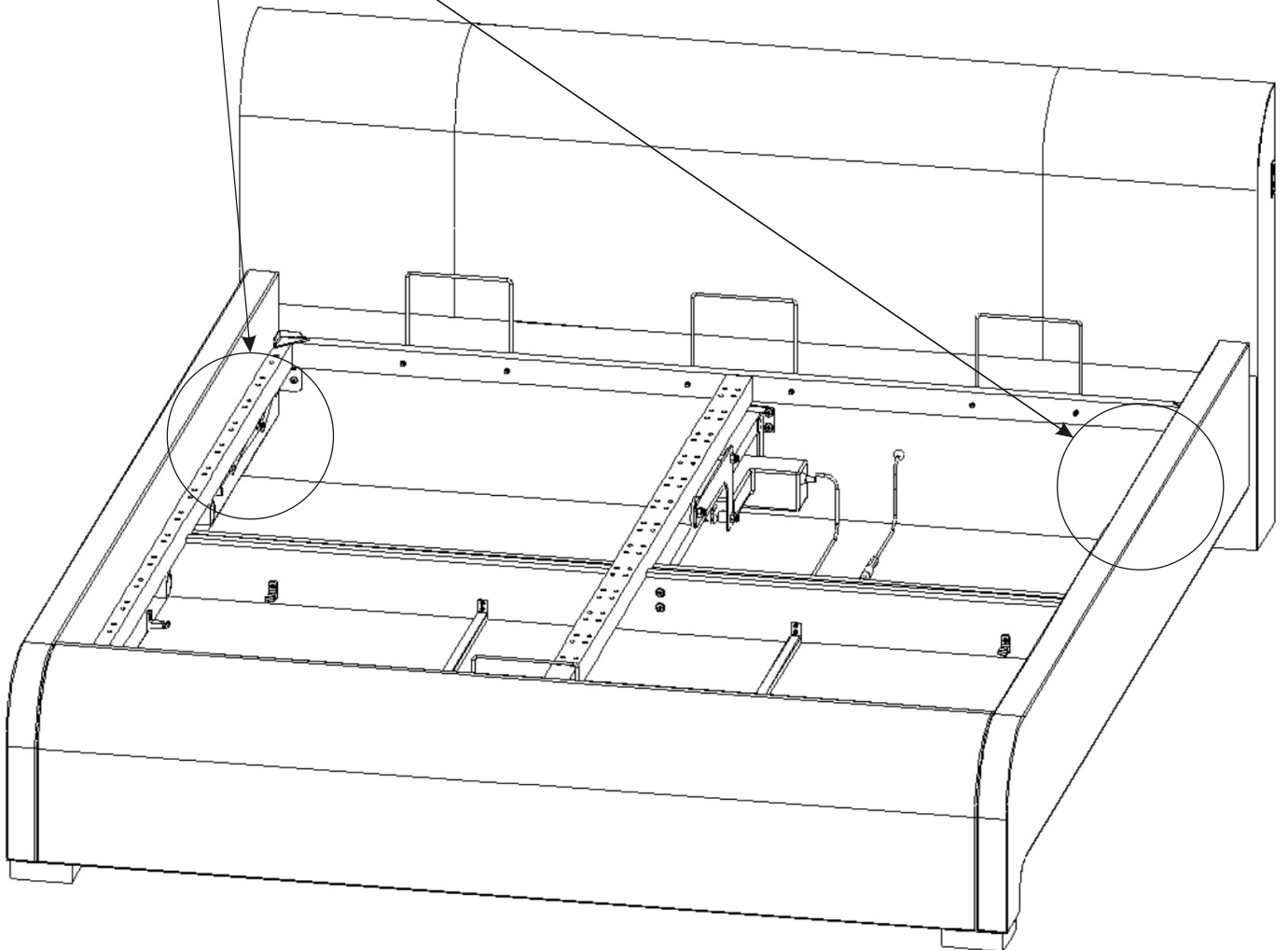

11.

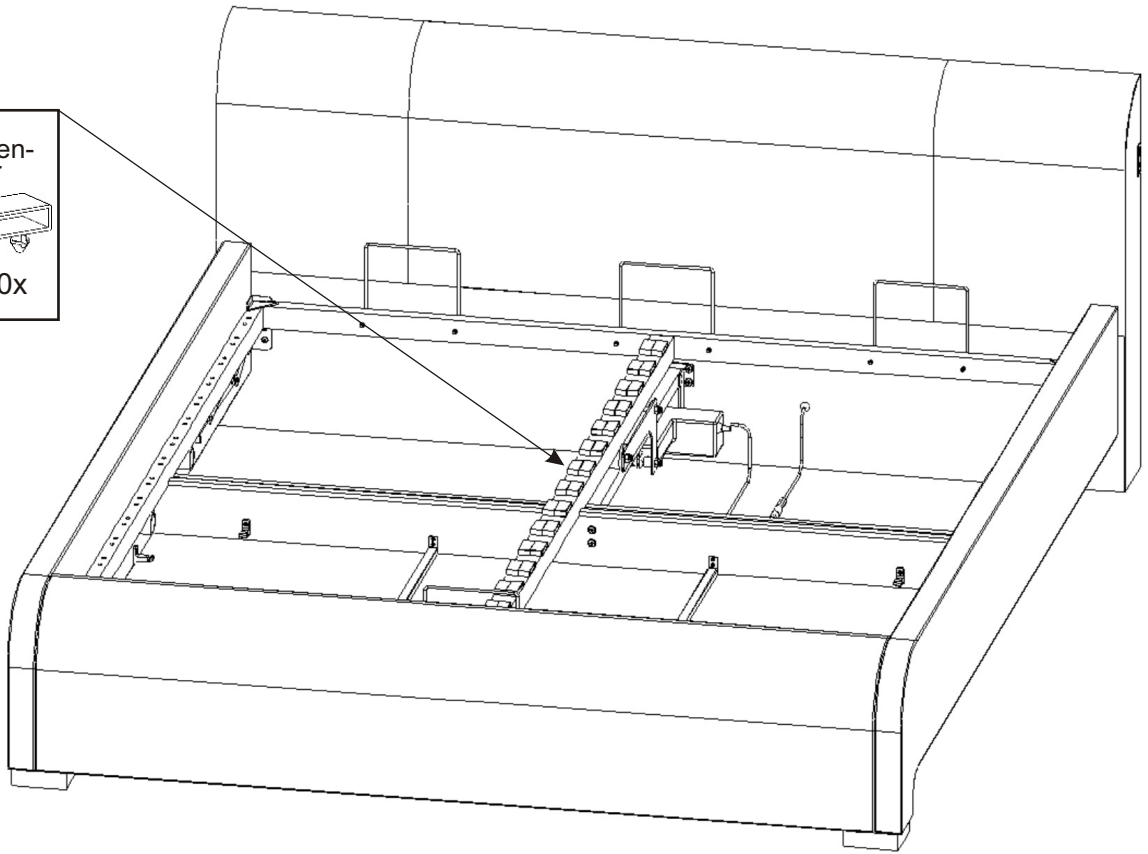

12.

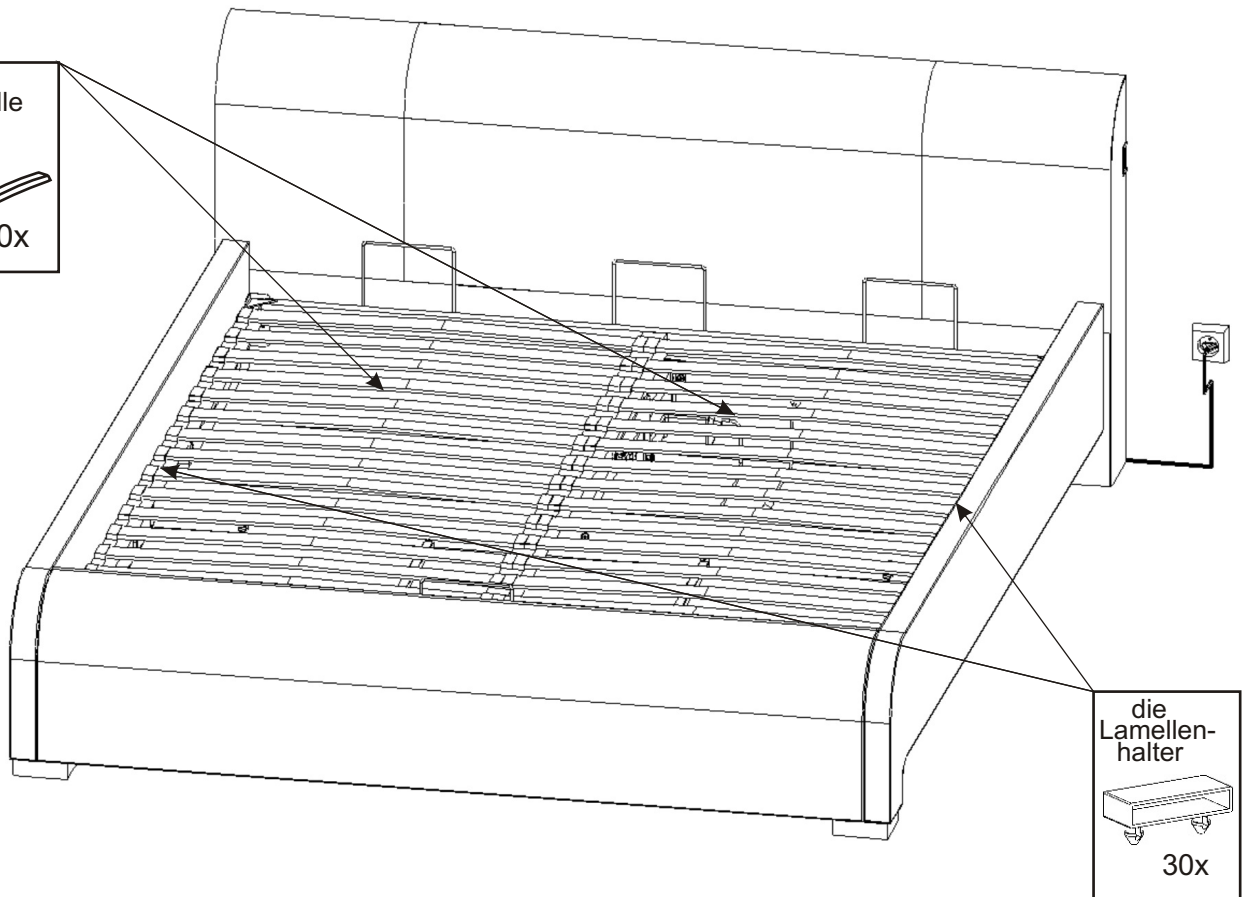
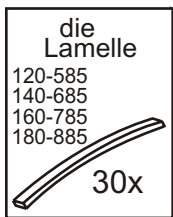

13.

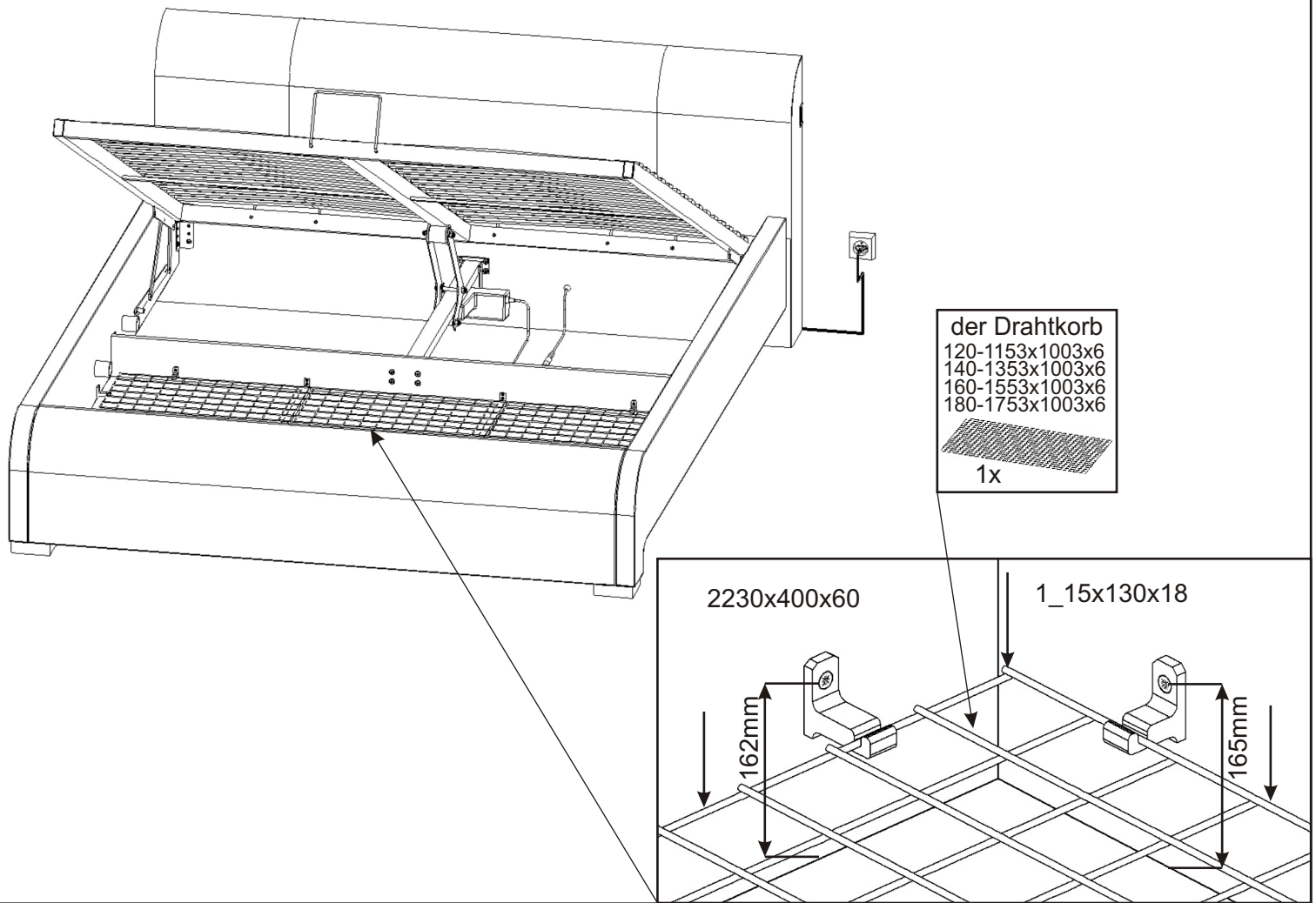

14.

